



SPECIFICATION SHEET

SPECIFICATION SHEET NO.	N0310- DFN1006501S5BL
DATE	Mar. 10, 2021
REVISION	A0
DESCRIPTION	SMD Plastic-Encapsulate ESD Protection Diodes, DFN1006 series ESD0501BL Type, Ultra Low Capacitance ESD Protection Diodes Reverse Working Voltage : 5.0V, Peak Pulse Power per: 100 Watts Operating Temp. Range -55°C ~+125°C, Package in Tape/Reel, 10,000pcs/Reel RoHS/RoHS III compliant
CUSTOMER	
CUSTOMER PART NUMBER	
CROSS REF. PART NUMBER	
ORIGINAL PART NUMBER	MDD ESD0501BL
PART CODE	DFN1006501S5BL

VENDOR APPROVE			
Issued/Checked/Approved			
DATE: March 10, 2021			

CUSTOMER APPROVE	
DATE:	

SMD ESD PROTECTION DIODES (TUBE) DFN1006 SERIES

MAIN FEATURE

- Transient protection for high speed data lines
- IEC61000-4-2 (ESD) ±15kV (air), ±8kV (contact)
- IEC61000-4-4 (EFT) 40A (5/50ns)
- Package optimized for high-speed lines
- Cable Discharge Event(CDE)
- Low clamping voltage
- Low leakage current
- Low Capacitance :0.5pF Typical.



APPLICATION

- Serial ATA
- Desktops, Servers and Notebooks
- Cellular Phone
- MDDI Ports
- Display Ports
- USB Data Line Protection
- Digital Visual Interface (DVI)

PART CODE GUIDE

RFQ

[Request For Quotation](#)

DFN1006	501	S	5BL
1	2	3	4

- 1) **DFN1006**: SMD Plastic-Encapsulate ESD Protection Diodes, DFN1006 series, 2 pads
- 2) **501**: Type code for original part number ESD0501BL
- 3) **S**: Package code, Package in Tape/Reel, 10000pcs/Reel
- 4) **5BL**: Marking code "5BL" on the case surface, Different Marking for different specification.

MORE ITEMS AVAILABLE

DFN1006501S5BL	DFN1006201SMOC	DFN1006401S0DH	DFN1006301S3BL	DFN100636VS0YN
DFN10063V3S0YA	DFN10065V0S0YB	DFN10068V0S0YC	DFN100612VS0YD	DFN1006301S03L
DFN1006302S32L	DFN1006501S00H	DFN1006501S05L	DFN1006501SFOC	DFN1006502S52L
DFN1006701SHOC				

SMD ESD PROTECTION DIODES (TUBE) DFN1006 SERIES

DIMENSION (Unit: mm)

Image for reference



Marking: 5BL



DFN1006

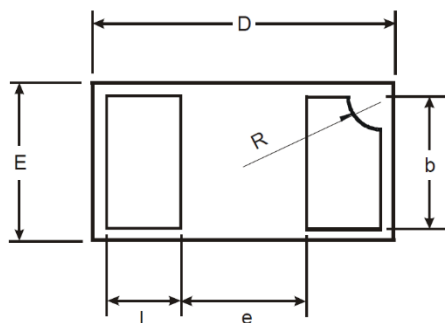

Symbol	Value (mm)		
	Min.	Typ.	Max.
A	0.45	0.50	0.550
b	0.45	0.50	0.55
D	0.95	1.00	1.05
E	0.55	0.60	0.650
e	-	0.40	-
L	0.90	1.00	1.05
R	0.07	0.12	0.17

Pin Configuration

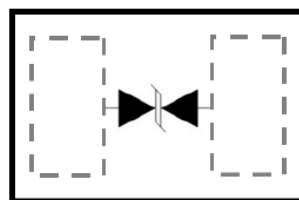

Recommend Pad Layout

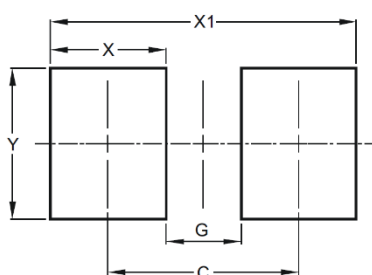

Circuit Diagram



Symbol	Unit (mm)
C	0.90
G	0.40
X	0.50
X1	1.10
Y	0.05

SMD ESD PROTECTION DIODES (TUBE) DFN1006 SERIES
MECHANICAL DATA

Case	Terminals	Flammability Rating	Marking	Weight per piece
JEDEC DFN1006 molded plastic body	Gold plated, solderable per MIL-STD-750, method 2026	UL 94V-0	5BL	0.00019 Ounce, 0.00591 grams

ABSOLUTE MAX. RATINGS AT Ta=25 °C (unless otherwise specified)

Parameter	SYMBOLS	VALUE	UNITS
		LIMIT	
ESD per IEC 61000-4-2 (Air)	V ESD	+/-20	KV
ESD per IEC 61000-4-2 (Contact)	V ESD	+/-20	KV
Peak Pulse Power(tp=8/20us waveform)	P PP	100	W
Lead Solder Temperature – Maximum (10 Second Duration)	T L	260(10 sec.)	°C
Operating Temperature Range	TOPT	-55 ~+ 125	°C
Storage Temperature Range	T STG	-55 ~ +150	°C

ABSOLUTE MAX. RATINGS AT Ta=25 °C (unless otherwise specified)

Parameter	SYMBOLS	VALUE			UNITS
		Min.	Typical	Max.	
Reverse Working Voltage Any I/O pin to Ground	V RWM			5.0	V
Reverse Breakdown Voltage @ I _T = 1.0mA Any I/O pin to Ground	V BR	6.0			V
Reverse Leakage Current @V _{RWM} = 5.0V, Any I/O pin to Ground	I R			100	nA
Clamping Voltage @ I _{PP} = 1A, t _p = 8/20µs Any I/O pin to Ground	V C			13	V
Clamping Voltage @ I _{PP} = 4A, t _p = 8/20µs Any I/O pin to Ground	V C			25	V
Capacitance VR = 0V, f = 1MHz Between I/O and GND	C J		0.5	-	pF

Note:
The above data are for reference only.

SMD ESD PROTECTION DIODES (TUBE) DFN1006 SERIES
RELIABILITY

Number	Experiment Items	Experiment Method And Conditions	Reference Documents
1	Solder Resistance Test	Test 260°C± 5°C for 10 ± 2 sec. Immerse body into solder 1/16" ± 1/32"	MIL-STD-750D METHOD-2031.2
2	Solderability Test	230°C ±5°C for 5 sec.	MIL-STD-750D METHOD-2026.1 0
3	Pull Test	1 kg in axial lead direction for 10 sec.	MIL-STD-750D METHOD-2036.4
4	Bend Test	0.5Kg Weight Applied To Each Lead, Bending Arcs 90 °C ± 5 °C For 3 Times	MIL-STD-750D METHOD-2036.4
5	High Temperature Reverse Bias Test	TA=100°C for 1000 Hours at VR=80% Rated VR	MIL-STD-750D METHOD-1038.4
6	Forward Operation Life Test	TA=25°C Rated Average Rectified Current	MIL-STD-750D METHOD-1027.3
7	Intermittent Operation Life Test	On state: 5 min with rated IRMS Power Off state: 5 min with Cool Forced Air. On and off for 1000 cycles.	MIL-STD-750D METHOD-1036.3
8	Pressure Cooker Test	15 PSIG, TA=121°C, 4 hours	MIL-S-19500 APPENOIXC
9	Temperature Cycling Test	-55°C~+125°C; 30 Minutes For Dwelled Time 5 minutes for transferred time. Total: 10 cycles.	MIL-STD-750D METHOD-1051.7
10	Thermal Shock Test	0°C for 5 minutes., 100°C for 5minutes, Total: 10 cycles	MIL-STD-750D METHOD-1056.7
11	Forward Surge Test	8.3ms Single Sale Sine-wave One Surge.	MIL-STD-750D METHOD-4066.4
12	Humidity Test	TA=65°C, RH=98% for 1000 hours.	MIL-STD-750D METHOD-1021.3
13	High Temperature Storage life Test	150°C for 1000 Hours	MIL-STD-750D METHOD-1031.5

SMD ESD PROTECTION DIODES (TUBE) DFN1006 SERIES

SUGGESTED REFLOW PROFILE (For Reference Only)

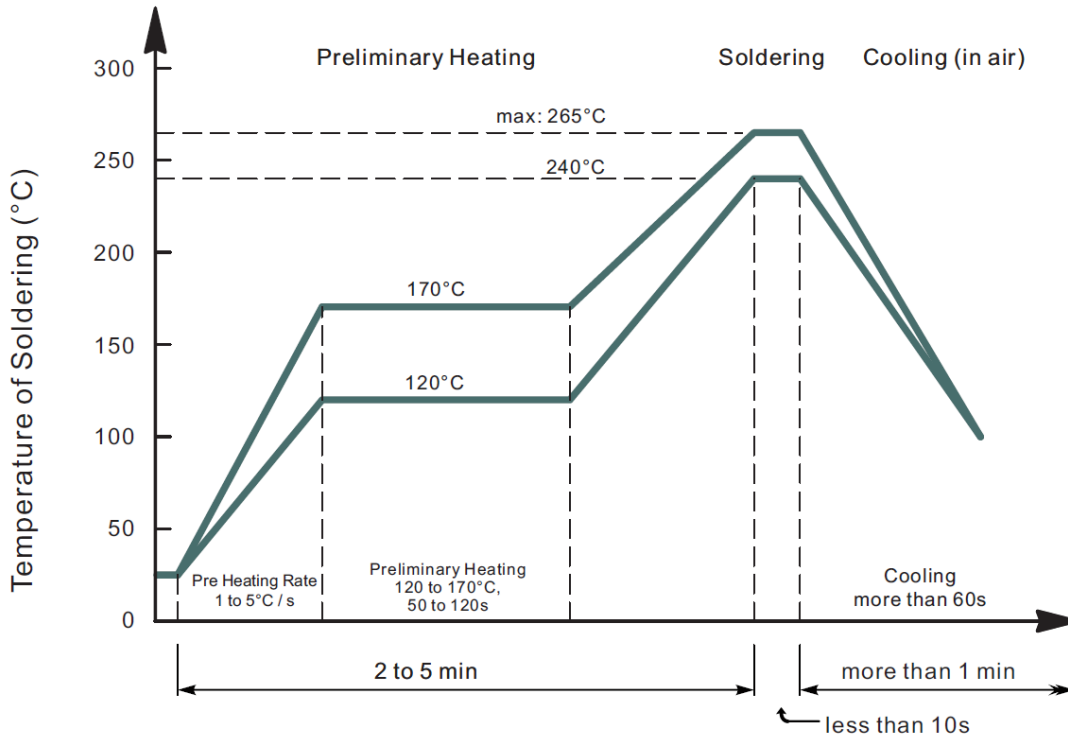

- Recommended peak temperature is over 245°C, If peak temperature is below 245 °C, you may adjust the following parameters; time length of peak temperature (longer), time length of soldering (longer), thickness of solder paste (thicker)
- Welding shall not exceed 2 times
- Remark: lead free solder paste (96.5 sn/3.0 Ag/0.5Cu)

SMD ESD PROTECTION DIODES (TUBE) DFN1006 SERIES

RATINGS AND CHARACTERISTIC CURVES (For Reference Only)

Fig 1 Power Derating Curve

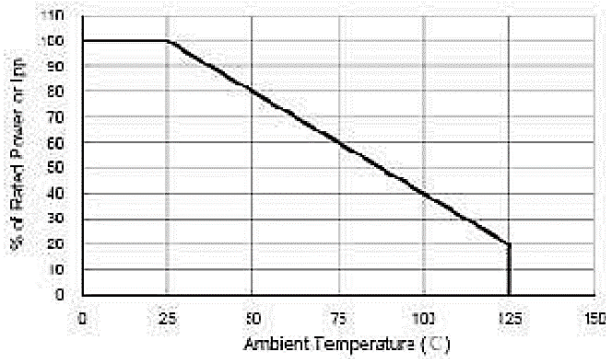

Fig 2 Clamping Voltage vs Peak Pulse Current

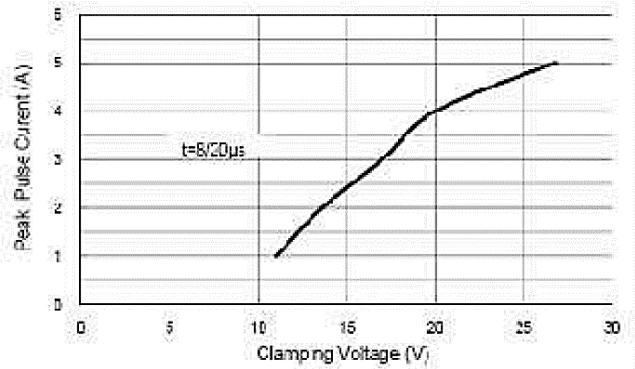

Fig 3 Voltage Sweeping

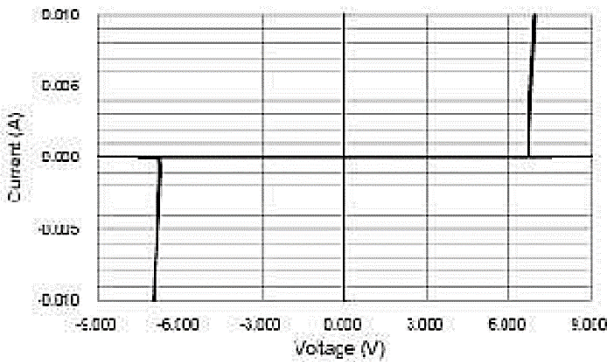

Fig 4 Voltage vs Capacitance

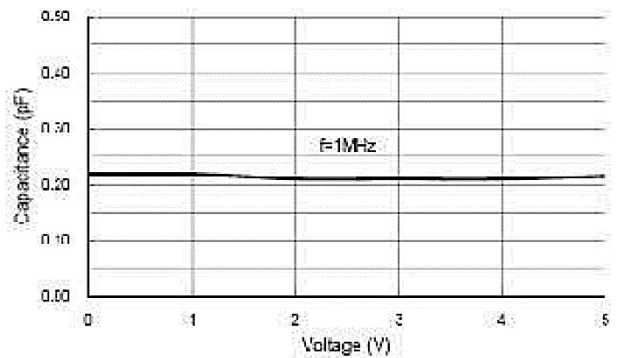

Fig 5 ESD Clamping (+8kV Contact per IEC 61000-4-2)

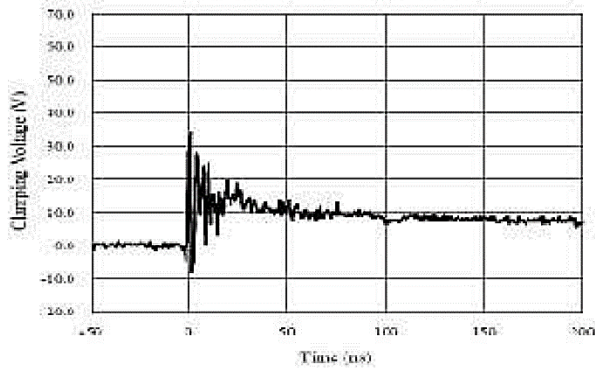
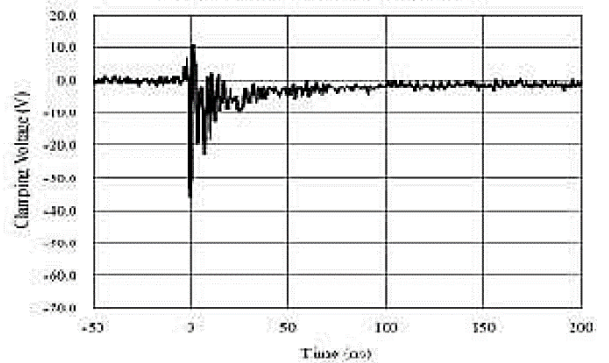
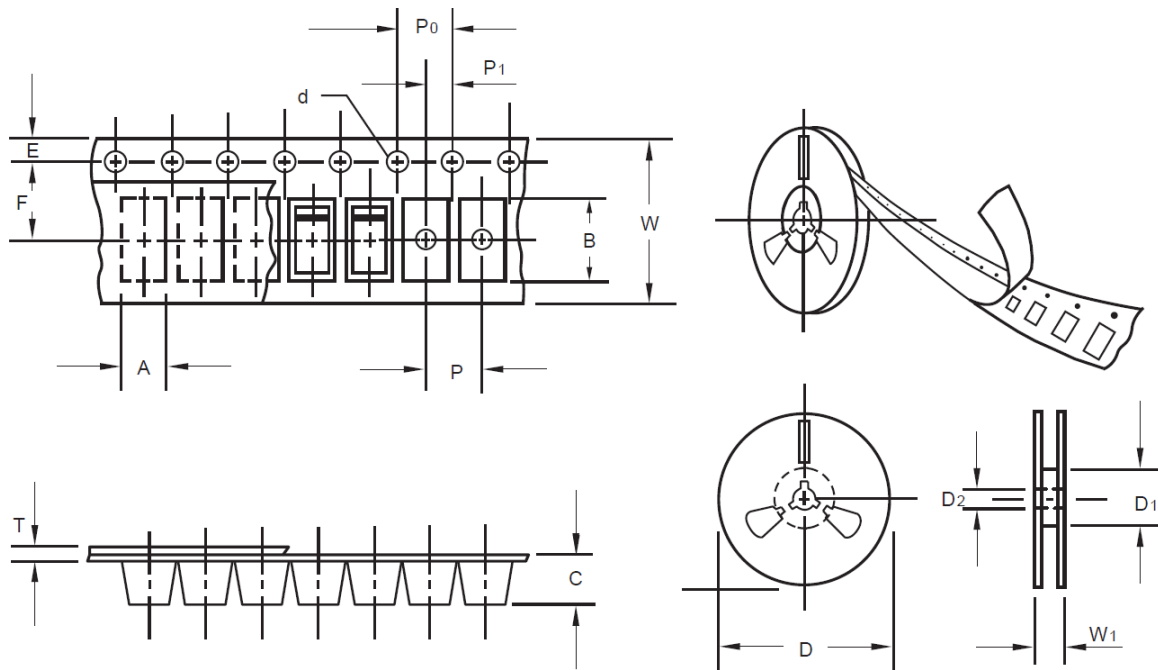

Fig 6 ESD Clamping (-8kV Contact per IEC 61000-4-2)



SMD ESD PROTECTION DIODES (TUBE) DFN1006 SERIES
TAPE/REEL (Unit: mm)

All Devices are packed in accordance with EIA standard RS-481-A and specifications.



Item	Symbol	Tolerance	DFN1006
Carrier width	A	0.1	2.10
Carrier Length	B	0.1	4.00
Carrier Depth	C	0.1	1.60
Sprocket hole	d	0.05	1.55
13" Reel outside diameter	-	-	-
13" Reel inner diameter	-	-	-
7" Reel outside diameter	D	2.0	178.00
7" Reel inner diameter	D1	Min.	50.00
Feed hole diameter	D2	0.5	13.00
Sprocket hole position	E	0.1	1.75
Punch hole position	F	0.1	3.50
Punch hole pitch	P	0.1	4.00
Sprocket hole pitch	P0	0.1	4.00
Embossment center	P1	0.1	2.00
Overall tape thickness	T	0.1	0.25
Tape width	W	0.3	8.15
Reel width	W1	1.0	10.50

SMD ESD PROTECTION DIODES (TUBE) DFN1006 SERIES

PACKAGE

Case Code	Reel Size	MPQ (pcs)	Component Spacing (mm)	Qty. Per Box (pcs)	Inner Box L*W*H (mm)	Reel Size (mm)	Carton size L*W*H (mm)	Qty. Per Carton (pcs)	G. W (kg)
DFN1006	7"	10,000		100,000	210*210*205	178	445*445*230	400,000	6.5

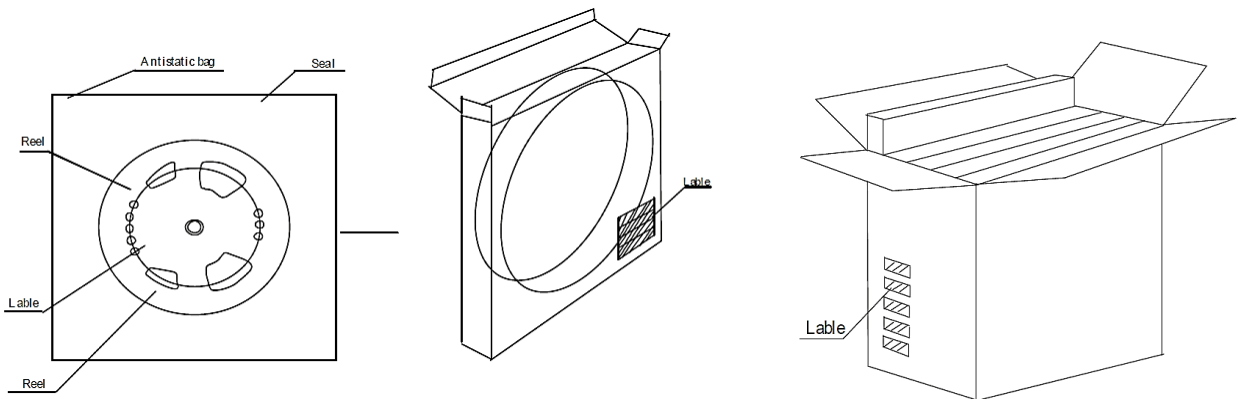

DISCLAIMER

NextGen Component, Inc. reserves the right to make changes to the product(s) and or information contained herein without notice. No liability is assumed as a result of their use or application. No rights under any patent accompany the sale of any such product(s) or information