



**SPECIFICATION SHEET**

<b>SPECIFICATION SHEET NO.</b>	N0529-DC455K0000S179
<b>DATE</b>	May 29, 2021
<b>REVISION</b>	A0
<b>DESCRIPTION</b>	<p>KHz SMD Discriminators 6260 Type L6.2*W6.0*H3.1mm 2 Pads CDBC Series            455.0KHz, Demodulated Bandwidth(3dB): <math>\pm 3.0</math>KHz Min from 455KHz            Operating Temp. Range -20°C ~+80°C            Reflow Profile Condition 260 °C Max.            In Tape/Reel, 2000pcs/Reel            RoHS III Complaint</p>
<b>CUSTOMER</b>	
<b>CUSTOMER PART NUMBER</b>	
<b>CROSS REF. PART NUMBER</b>	
<b>ORIGINAL PART NUMBER</b>	TGS CDBC 455C79 TLF
<b>PART CODE</b>	DC455K0000S179

<b>VENDOR APPROVE</b>		
Issued/Checked/Approved		
		
DATE: May 29, 2021		

<b>CUSTOMER APPROVE</b>	
DATE:	

**KHZ SMD CERAMIC DISCRIMINATOR CDBC SERIES**

**MAIN FEATURE**

- KHz SMD Ceramic Discriminator 6260 Type 2 pads
- White case, L6.2\*W6.0\*H3.1mm
- Low cost and short shipment
- Reflow Profile Condition 260 °C Max.
- Cross main competitors parts CDBC and JTC series
- RoHS/RoHS III compliant
- For quadrature detection with IC: TOSHIBA/TB32302FG



**APPLICATION**

- Communication Electronics

**PART CODE GUIDE**

**RFQ**  
Request For Quotation

<b>DC</b>	<b>455K0000</b>	<b>S</b>	<b>179</b>
1	2	3	4

- 1) DC: Part family Code for KHz SMD Ceramic Discriminator 6260 Type L6.2\*W6.0\*H3.1mm 2 Pads
- 2) 455K0000: Frequency range code for 455.0000KHz
- 3) S: SMD type, Package Tape/Reel, 2000pcs/Reel
- 4) 179: Specification code for original part No.: **TGS CDBC 455C79 TLF**

**KHZ SMD CERAMIC DISCRIMINATOR CDBC SERIES**

**DIMENSION (Unit: mm, Tol. +/-0.15mm)**

Image for reference

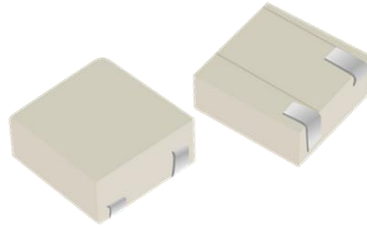

CDBC

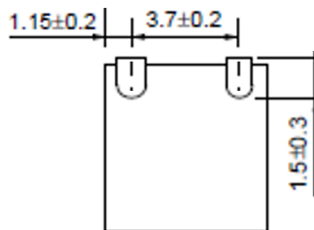
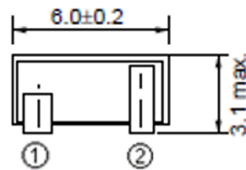
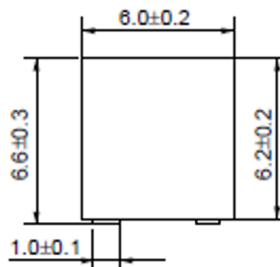

**Marking**

Line 1: Series Code  
Line 2: Frequency Range  
+Internal Code

**Connection**

Pin 1: Input  
Pin 2: Output

Measuring Circuit

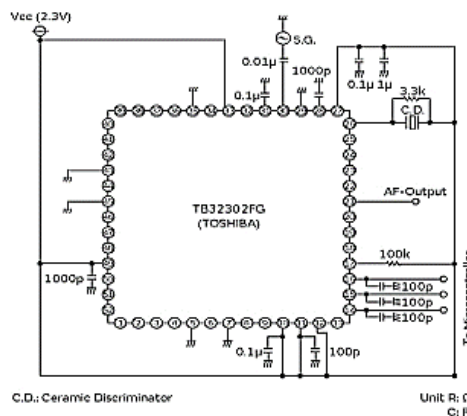

C.D.: Ceramic Discriminator

Unit R: Ω  
C: F

## KHZ SMD CERAMIC DISCRIMINATOR CDBC SERIES

**ELECTRICAL PARAMETERS**

Parameter	Part No. Symbol	Units	Value			Condition
			Min.	Typical	Max.	
Original Manufacturer	TGS	TGS Crystals				
Holder Type	CDBC	KHz SMD Discriminator 6260 Type L6.2*W6.0*H3.1mm 2 Pads				
Frequency Range (f0)	455	KHz	455.000		@ ± 1.0KHz	
Bandwidth	C79	KHz	±3.0		@3dB Bandwidth, f0	
Operation Temperature		°C	-20		+80	
Storage Temperature		°C	-40		+85	
Demodulated Output		mV		145±40		@ f0
Demodulated Distortion Factor		%			-	@ 455KHz
Temperature Stability		%	0.3		@-20 ~+80 °C	
IC Model No.		TOSHIBA/TB32302FG				
Withstand Voltage		DC 5.0V 1 minute				
Other		Package	T	Tape/Reel, 2000pcs/Reel		
	RoHS Status	LF	RoHS III compliant			
	Add Value		N/A			
	Special Code		For Internal Control, Blank: N/A			

Note: Original Part Number: TGS CDBC 455C79 TLF

**INPUT SIGNAL CONDITION**

Item	Unit	Value
Input	dBm	-80.0
Deviation	KHz	±4.0
Frequency Modulation	KHz	1.0

**KHZ SMD CERAMIC DISCRIMINATOR CDBC SERIES**

**TEST METHOD**

Test Items	Test Method And Conditions	Requirement
<b>Demodulated 3dB Bandwidth</b>	<p>Input the above signal and sweep the carrier around 455 kHz, and find Out the maximum audio output frequency. Then sweep the carrier frequency again and find two frequencies, which are observed –3dB attenuation points from the maximum point.</p> <p>Higher frequency point is called (f1) and lower called (f2). (F1-455KHz) is defined as upper 3dB bandwidth and (455KHz-f2) defined as lower 3dB bandwidth.</p>	<p>It shall meet the specification</p>
<b>Demodulate Output</b>	<p>Demodulated output shall be measured when carrier frequency is adjusted to 455KHz.</p>	<p>It shall meet the specification</p>
<b>Demodulated Distortion Factor</b>	<p>Carrier frequency is adjusted to 455KHz.And distortion shall be measured with 1 kHz modulation frequency.</p>	<p>It shall meet the specification</p>
<b>Input signal condition</b>	<p>Input signal condition, Input level - 80dBμ; Frequency Deviation – 4.0KHz; Modulation Frequency: 1.0KHz</p>	
<b>Measurement Condition</b>	<p>Unless otherwise noted, the standard range of atmospheric conditions for measurements and tests are as follows: Ambient temperature:5°C to 35 °C Relative humidity :45% to 85% Air pressure :86Kpa to 106 Kpa If there is doubt about the results, measurement shall be made within the following limits: Ambient temperature: 18°C to 22 °C Relative humidity :60% to 70% Air pressure: 86Kpa to 106 Kpa</p>	

## KHZ SMD CERAMIC DISCRIMINATOR CDBC SERIES

**RELIABILITY**

Test Items	Test Method And Conditions	Requirement
<b>Humidity</b>	After being placed in a chamber with 90-95% R.H. at 40±2°C for 100 hours and then being placed in room temperature for 1 hour, filter shall be measured.	It shall meet Table 1.
<b>High Temperature</b>	After being placed in a chamber with 80±2 °C, for 100 hours and then being placed in room temperature for 1 hour, filter shall be measured.	It shall meet Table 1.
<b>Low Temperature</b>	After being placed in a chamber with -20±2 °C, for 100 hours and then being placed in room temperature for 1 hour, filter shall be measured.	It shall meet Table 1.
<b>Heat Shock</b>	After being kept at room temperature, filter shall be placed at temperature of -55 °C , for 30 minutes, then be placed at temperature. 85 °C, for 30 minutes. After that returned to -55 °C again. Repeated above cycle for 5 times. After being kept in room temp. for 1 hour, filter shall be measured	It shall meet Table 1.
<b>Resistance to Solder Heat</b>	Lead terminals are immersed up to 1.5mm from filter’s body in soldering bath of 350± 10°C, for 3±0.5 sec. And then filter shall be measured after being placed in room temperature for 1 hour.	It shall meet Table 1.
<b>Solderability</b>	Lead terminals are immersed in aide solder for 5 sec and then immersed in soldering bath of 230±5°C, for 3±0.5 sec. At least 95% lead terminals shall be covered with solder	It shall meet Table 1.
<b>Drop Test</b>	Filter shall be measured after 3 times random drops from the height of 30 cm on concrete floor	No visible damage and it meet Table 1
<b>Adhesion</b>	A static load of 20N to the direction of the arrow (see Fig. 4) shall be applied on the core of the Component and hold for 10 seconds. Filter shall be soldered correctly and tightly to PCB.	It shall meet Table 1.
<b>Vibration</b>	Filter shall be measured after being applied vibration of amplitude of 1.5mm with 10-55Hz band of vibration frequency to each of 3 perpendicular directions for 2 hours	No visible damage and it meet Table 1
<b>Substrate Bending Test</b>	Apply pressure in the direction of arrow (see Fig. 3) at a rate of about 0.5mm per second until it reaches a bend of 3mm and hold for 30 seconds.	It shall meet Table 1.

**Table1**

Item	Center Frequency	Demodulated Bandwidth(3dB)	Demodulated Output	Temperature Stability
Specification	455KHz	±3.0KHz Min.	145±40mV. (at 455 kHz)	0.3%Max. @-20 ~+80 °C

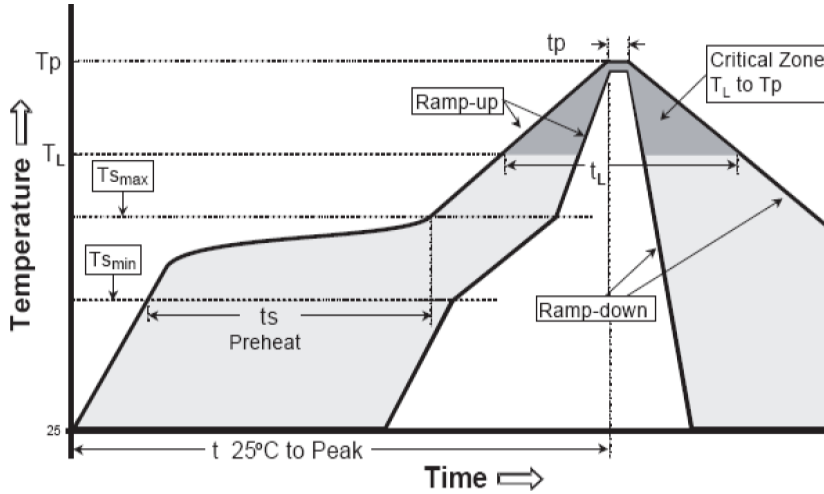
**KHZ SMD CERAMIC DISCRIMINATOR CDBC SERIES**
**SUGGESTED REFLOW PROFILE (For Reference Only)**

<b>Profile Feature</b>		Pb-Free Assembly
<b>Average Ramp-up Rate (Ts Max to Tp)</b>		3°C/second Max
<b>Preheat</b>	<b>Temperature Min (Ts Min.)</b>	125°C
	<b>Temperature Max (Ts Max.)</b>	200°C
	<b>Time (ts Min. to ts Max.)</b>	60 ~ 180 seconds
<b>Time maintained above</b>	<b>Temperature (T<sub>L</sub>)</b>	217°C
	<b>Time (t<sub>L</sub>)</b>	60 ~ 150 seconds
<b>Peak/Classification Temperature (T<sub>p</sub>)</b>		260 °C
<b>Time within 5°C of actual Peak Temperature (t<sub>p</sub>)</b>		20 ~ 40 seconds
<b>Ramp-down rate</b>		6 °C /Second Max.
<b>Time 25 °C to Peak Temperature</b>		8 minutes Max.
<b>Suggest reflow times</b>		3 Times Max.

**KHZ SMD CERAMIC DISCRIMINATOR CDBC SERIES**

**REEL DIMENSION (Unit: mm, 2000pcs/Reel)**

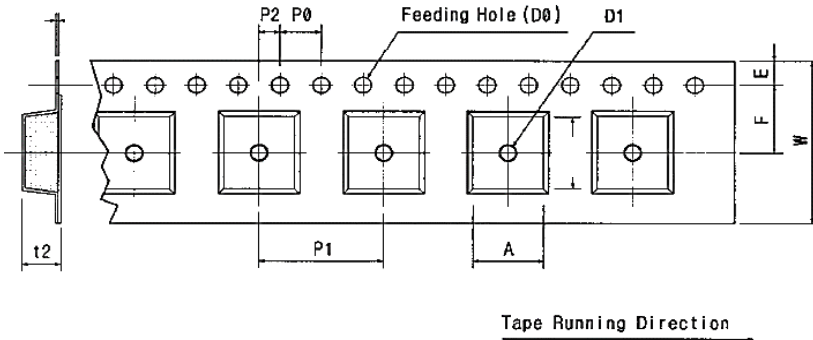

Code	Dimension
W	16.0+/-0.30
F	6.80+/-0.20
E	1.75+/-0.10
P 0	4.00+/-0.10
P 1	7.80+/-0.10
P 2	2.00+/-0.05
D 0	∅1.5+/-0.10
D 1	∅1.5+/-0.10
t 2	3.60+/-0.10
A	7.70+/-0.10

**TAPE DIMENSION (Unit: mm)**

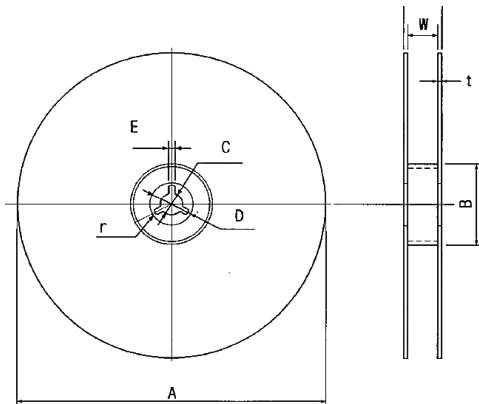

Code	Dimension
A	∅330+/-1.0
B	∅80.0+/-0.5
C	∅13.0+/-0.5
E	2.00+/-0.3
W	16.0+/-1.0

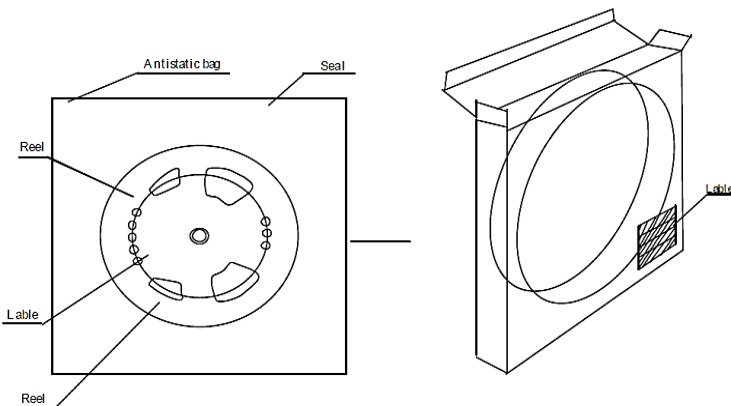

**DISCLAIMER**

NextGen Components, Inc. reserves the right to make changes to the product(s) and or information contained herein without notice. No liability is assumed as a result of their use or application. No rights under any patent accompany the sale of any such product(s) or information