



SPECIFICATION SHEET

SPECIFICATION SHEET NO.	Q1226- EM104Z05H11CCA	
DATE	Dec. 26, 2023	
REVISION	A0	Updated With Most Recent Data - Official First Release
DESCRIPTION AND MAIN PARAMETRICS	<p>Electric Double Layer Capacitors/Coin Supercapacitor, Type RH, EM series Capacitance: 0.1F, Tolerance -20%~+80%, Voltage 5.5V, Dimension: ØD13.4*H13.5mm, Lead Space 5.0mm, ESR AC @1kHz, 20°C: 50 ohm Max. Leakage Currnt: 1µA @72 hours Operating Temp. Range -25°C ~+70°C, Package in Bulk RoHS/RoHS III Compliant & Halogen Free</p>	
CUSTOMER		
CUSTOMER PART NO.		
CROSS REF. PART NO.		
ORIGINAL MFG/PART NO.	Aillen/CEE104Z05HEM11CRC	
PART CODE	EM104Z05H11CCA	

VENDOR APPROVE			
Issued/Checked/Approved			
DATE: Dec. 26, 2023			

CUSTOMER APPROVE	
DATE:	

12/26/2023

ELECTRIC DOUBLE LAYER CAPACITORS EM SERIES

MAIN FEATURE

- Coin Type Supercapacitor
- High Power Density
- Cross Competitors Parts and more.
- RoHS/RoHS III Compliant & Halogen Free



APPLICATION

- Power Assist Circuits and DDR Power Backup
- Micro Energy Storage
- IoT Energy Harvesting
- SSD applications
- RTC System power transfer to battery backup

ELECTRICAL CHARACTERISTICS

See Page 4 For Different Part Code

HOW TO ORDER

Please follow up Part Code Guide and indicate pat code when you order or RFQ.

ELECTRIC DOUBLE LAYER CAPACITORS EM SERIES
PART CODE GUIDE

Full Order Part Code: EM104Z05H11CCA

RFQ
[Request For Quotation](#)

CODE	NAME	KEY SPECIFICATION OPTION
EM	Electric Double Layer Capacitors - Coin Supercapacitor Series Code	EM series
104	Rated Capacitance Code	104: 0.1F; 224: 0.22F; 334: 0.33F; 474: 0.47F; 684: 0.68F; 105: 1.0F; 106: 10F; 107: 100F; 155: 1.5F
Z	Capacitance Tolerance Code	B: -10% ~ +30%, D: 0% ~ +80%, M: ±20%; N: ±30%; Z: -20% ~ +80%,
05	Rated Voltage Code	05: 5.5V
H	Environmental Requirements code	R: RoHS III Complaint; H: RoHS III Complaint & Halogen Free
1	Diameter code	2: ØD8.5mm; 3: ØD10.5mm; E: ØD6.3mm; V: ØD7.0mm; F: ØD8.0mm; G: ØD10.0mm; 6: ØD11.7mm; I: ØD12.5mm; J: ØD13.0mm; 1: ØD13.4mm; K: ØD16.0mm; L: ØD18.0mm; Z: ØD19.1mm; T: ØD20.9mm
1C	Case Height code	<ul style="list-style-type: none"> When the code is number, it represent the actual height. 05: H5.0mm; 07: H7.0mm; 09: H9.0mm; 10: H10mm; 16: H16mm When the code is alphabet + number X7: H6.70mm; N2: H6.20mm; N5: H9.50mm; T3: H10.3mm; T7: H12.5mm; 1C: H13.5mm; F2: H14.2mm; S7: H16.7mm; I7: H19.7mm; R2: H24.2mm
C	Terminal Type Code	C: Type RC; H: Type RH; V: Type RV
A	Internal Control Code or special Parameters code	letter A~Z or digits (1-9); Blank: N/A

ELECTRIC DOUBLE LAYER CAPACITORS EM SERIES
MAINL ELECTRICAL PARAMETERS





PART CODE	RATE VOLTAGE (V.DC)	RATED CAP. (F)	SIZE Φ D X H (mm)	LEAD SPACE P(mm)	ESR AC (Ω) (Max.) @ 1KHz/20°C	LEAKAGE CURRENT (μ A/72hrs)
EM104Z05H11CCA	5.5	0.1	13.4*13.5	5.0	50	1
EM104Z05H6N2HA	5.5	0.1	11.7*6.2	10.0	50	1
EM104Z05H6S7VA	5.5	0.1	11.7*16.7	5.0	50	1
EM105Z05HTF2CA	5.5	1.0	20.9*14.2	5.0	15	2
EM105Z05HZR2VA	5.5	1.0	19.1*24.2	5.2	15	2
EM105Z05HZT3HA	5.5	1.0	19.1*10.3	19.2	15	2
EM155Z05HTF2CA	5.5	1.5	20.9*14.2	5.0	15	3
EM155Z05HZR2VA	5.5	1.5	19.1*24.2	5.2	15	3
EM155Z05HZT3HA	5.5	1.5	19.1*10.3	19.2	15	3
EM224Z05H11CCA	5.5	0.22	13.4*13.5	5.0	40	1
EM224Z05H6N2HA	5.5	0.22	11.7*6.2	10.0	40	1
EM224Z05H6S7VA	5.5	0.22	11.7*16.7	5.0	40	1
EM334Z05H11CCA	5.5	0.33	13.4*13.5	5.0	40	1
EM334Z05H6N2HA	5.5	0.33	11.7*6.2	10.0	40	1
EM334Z05H6S7VA	5.5	0.33	11.7*16.7	5.0	40	1
EM474Z05H11CCA	5.5	0.47	13.4*13.5	5.0	40	2
EM474Z05H6N2HA	5.5	0.47	11.7*6.2	10.0	40	2
EM474Z05H6S7VA	5.5	0.47	11.7*16.7	5.0	40	2

Note

1. Specification is subject to changed without notice, please contact us for any update.
2. The sizes in the above table are all general specifications. If you need other specifications, please contact us.

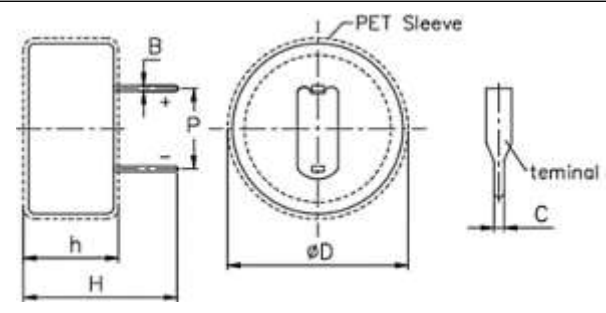
12/26/2023

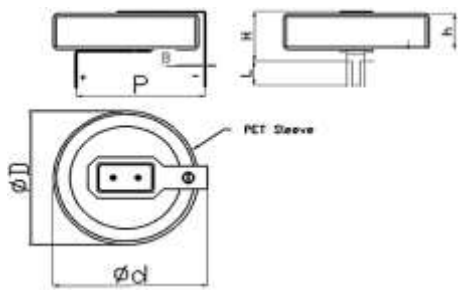
ELECTRIC DOUBLE LAYER CAPACITORS EM SERIES
DIMENSION (Unit: mm)

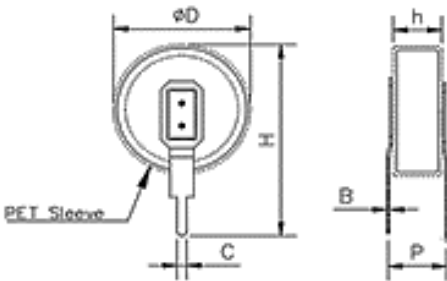
TYPE CODE	IMAGE (Only for reference)	DIMENSION
RC		
RH		
RV		

Symbol	Type RC	Type RH	Type RV
D	13.4±0.5	11.7±0.5	11.7±0.5
d	-	12.5±0.5	-
h	7.0±0.5	4.5±0.5	4.5±0.5
H	13.5±0.5	6.2±0.5	16.7±0.5
P	5.0±0.5	10±0.5	5.0±0.5
C	0.8±0.1	0.8±0.1	0.8±0.1
B	0.5±0.1	0.2±0.05	0.2±0.05
L	-	3.0±0.5	-

ELECTRIC DOUBLE LAYER CAPACITORS EM SERIES

CONSTRUCTION

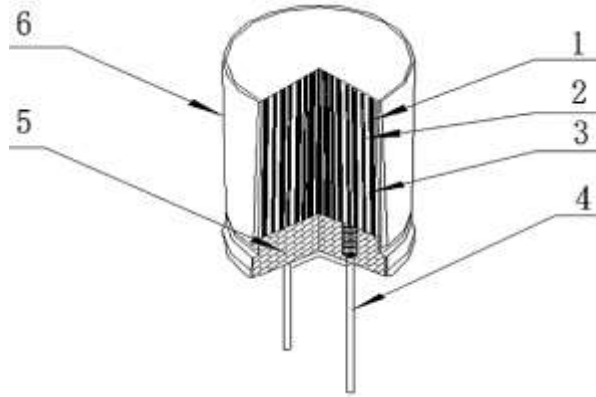

NO.	PARTS	MATERIAL
1	Al-Foil (+)	High Pure Aluminum Carbon Foils
2	Al-Foil (-)	High Pure Aluminum Carbon Foils
3	Separator	Cellulose Fibre/Acrylic Fiber
4	Lead line	High Pure Aluminum, lead Is Tin Copper Clad Steel Wire
5	Sealing	Rubber
6	Case	High Purity Aluminum Foil

ELECTRIC DOUBLE LAYER CAPACITORS EM SERIES

CHARACTERISTICS

Standard Atmospheric Conditions

The standard range of atmospheric conditions for making measurements/test as follows:

Ambient temperature: 5 °C to 35 °C

Relative humidity: < 85%

Air Pressure: 86kPa to 106kPa

If there is any doubt about the results, measurement shall be made within the following conditions:

Ambient temperature: 25 °C \pm 2 °C

Relative humidity: 25% to 75%

Air Pressure: 86kPa to 106kPa

Operating Temperature Range

The ambient temperature range at which the capacitor can be operated continuously at rated voltage is

(5.5WV) -25 °C to 70 °C.

As to the detailed information, please refer to Page 8

ELECTRIC DOUBLE LAYER CAPACITORS EM SERIES

GENERAL ELECTRICAL PARAMETERS -

Refer to IEC 62391-1, GB/T34870.1 -- 2017 test standards

PARAMETER	UNIT	VALUE	CONDITION
Temperature range	°C	-25 to 70	-
Capacitance	F	0.1 ~ 4.0	See Page 3 Rated Capacitance Code Product nominal capacity, test frequency: 120Hz, within the specified capacity tolerance 25°C ΔV=2.16-1.08 I=50mA
Capacitance Tolerance	%	-20~+80 (Std.)	See Page 3 Capacitance Tolerance Code
Working voltage	V	5.5	Rated working voltage at 25°C
Surge Voltage	V	5.8	-
ESR Max AC	mΩ	Refer to Page 4	Equivalent series resistance, test frequency 1kHz
Leakage Current	μA	Refer to Page 4	at 72h at 25°C
Self Discharge Characteristics	The voltage between the positive and negative electrode ≥ 4.2V		Charging process: <ul style="list-style-type: none"> Normal temperature, non-loaded, charge at rated voltage for 8h Lay aside process: <ul style="list-style-type: none"> temperature less than 25°C, relative humidity less than 60%RH, lay aside 24h at open circuit

ELECTRIC DOUBLE LAYER CAPACITORS EM SERIES

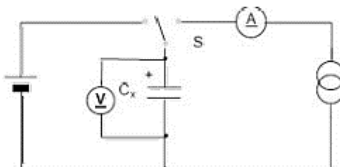
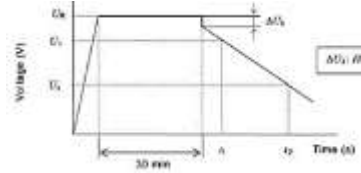
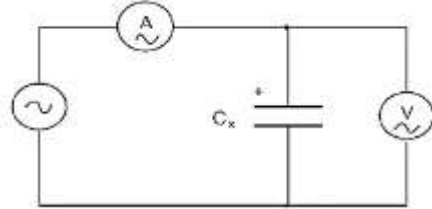
ITEM	PERFORMANCE
<p>Nominal Capacitance (Tolerance)</p>	<p><Condition> Constant Current Discharge of Measure</p> <ul style="list-style-type: none"> • Set the DC voltage source to the rated voltage (UR). • Sets constant current values of a specified constant current discharge device. • Switch the switch S to DC power supply , constant voltage charge for 30min after the voltage reach to rated voltage. • After charging 30min , transform the switch S to constant current discharge device the to discharge at constant current. • Measure the discharge time from U1 to U2 (t1、 t2), Calculate capacitance using the following formula: <div style="display: flex; align-items: center; justify-content: space-around;">   <div style="text-align: right;"> $C = \frac{I \times (t_2 - t_1)}{U_1 - U_2}$ </div> </div> <p><Criteria> Shall be within the specified capacitance tolerance</p>
<p>Internal Resistance</p>	<p><Condition> After 2 minutes applications of rated working voltage at 20°C, Equivalent series resistance: ESR shall be measured from the circuit below: ESR Ra can be calculated from the formula: $R_a = \frac{U}{I}$ Equivalent series resistance (mΩ/Ω); U Ac voltage valid values (V r.m.s) I Ac current valid values (V r.m.s)</p> <div style="text-align: center;">  </div> <p><Criteria>: Refer to Page 4.</p>

ELECTRIC DOUBLE LAYER CAPACITORS EM SERIES

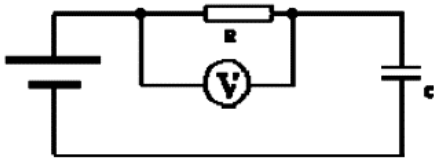
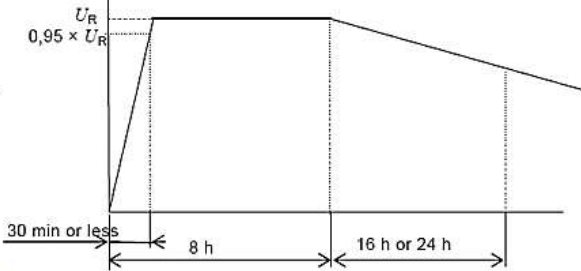
ITEM	PERFORMANCE
Leakage Current	<p><Condition></p> <p>Leakage Current shall be measured from the circuit below:</p> <ul style="list-style-type: none"> • Discharge: Before the start of the measurement, supercapacitor should be fully discharge, discharge process for 1 h to 24 h. • Leakage current measurement shall be carried out under the rated temperature and voltage rating(U_R).The voltage of product reached 95% rated voltage after the biggest charging time for 30min , Charging time chooses from 30min($\leq 1F$), 1h($\geq 1F$), 2h($\geq 10F$), 4h($\geq 20F$), 72h($\geq 120F$). • Should use a stable power supply, such as DC regulated power supply. • Charge process should be through the protection under 1000Ω resistance:  <p><Criteria></p> <p>Refer to Page 4</p>
Self Discharge	<p><Condition></p> <p>Before the start of the measurement ,super capacitor should be fully discharge, discharge process for 1 h to 24 h. Charge the super capacitor to rated voltage without protection resistance, charging time for 8h(include the voltage of product reached 95% rated voltage after the biggest charging time for 30min).Disconnect the super capacitor from the power supply. Super capacitor should be placed in the standard atmospheric pressure conditions for 24 h. Dc voltmeter internal resistance should be greater than 1 mΩ.</p> 

ELECTRIC DOUBLE LAYER CAPACITORS EM SERIES

ITEM	PERFORMANCE
<p>Temperature Characteristic</p>	<p><Condition> Leakage Current shall be measured from the circuit below:</p> <ul style="list-style-type: none"> • Step 1: Testing Temperature (°C): 20±2 ; Time: Time to reach thermal equilibrium Test project: Cap.\ESR • Step 2: Testing Temperature (°C): -25±2 ; Time: 2 Hours Test project: Cap.\ESR • Step 3: Testing Temperature (°C): 70±2 ; Time: 16 Hours Test project: Cap.\ESR <p><Criteria> The characteristic shall meet the following requirements:</p> <ul style="list-style-type: none"> • At -25°C Compared with the initial value: Capacitance Change Within ±50% of initial value; Internal Resistance ≤4 times of initial specified value • At 70°C Compared: with the initial value: Capacitance Change Within ±30% of initial value; Internal Resistance ≤ Initial specified value
<p>Load Life Test</p>	<p><Condition> The capacitor shall be subjected to 1000 hours application of rated voltage at +70°C, Then the product should be tested after 16 hours recovering time at atmospheric conditions. The result should meet the following table:</p> <p><Criteria> The characteristic shall meet the following requirements:</p> <ul style="list-style-type: none"> • Capacitance Change Within ±40% of initial value; • Internal Resistance ≤4 times of initial specified value; • Appearance: There shall be no leaked electrolyte or other mechanical damage
<p>Shelf Life Test</p>	<p><Condition> The capacitor shall be stored at +70°C temperature specified below for 1000 hours. During which time no voltage shall be applied. Then the product should be tested after 16 hours recovering time at atmospheric conditions. The result should meet the following table:</p> <p><Criteria> The characteristic shall meet the following requirements:</p> <ul style="list-style-type: none"> • Capacitance Change Within ±20% of initial value; • Internal Resistance ≤3 times of initial specified value; • Appearance: There shall be no leaked electrolyte or other mechanical damage

ELECTRIC DOUBLE LAYER CAPACITORS EM SERIES

ITEM	PERFORMANCE
Damp Heat Test	<p><Condition></p> <p>The capacitor shall be stored at a temperature of $40\pm 2^{\circ}\text{C}$ and relative humidity of 90 to 95% for 240 ± 8 hours. And then the capacitor shall be subjected to standard atmospheric conditions for 1 to 2 hours, after which measurements shall be made.</p> <p><Criteria></p> <p>The characteristic shall meet the following requirements:</p> <ul style="list-style-type: none"> • Capacitance Change Within $\pm 30\%$ of initial value; • Internal Resistance ≤ 2 times of initial specified value; • Appearance: There shall be no leaked electrolyte or other mechanical damage
Cyclic Life	<p><Condition></p> <p>The capacitor shall be cycles between specified voltage and half rated voltage under constant current at $+25^{\circ}\text{C}$ (500,000 cycles) And then the capacitor shall be subjected to standard atmospheric conditions for 6 to 8 hours, after which measurements shall be made:</p> <p><Criteria></p> <p>The characteristic shall meet the following requirements:</p> <ul style="list-style-type: none"> • Capacitance Change Within $\pm 40\%$ of initial value; • Internal Resistance ≤ 4 times of initial specified value; • Appearance: There shall be no leaked electrolyte or other mechanical damage

ELECTRIC DOUBLE LAYER CAPACITORS EM SERIES

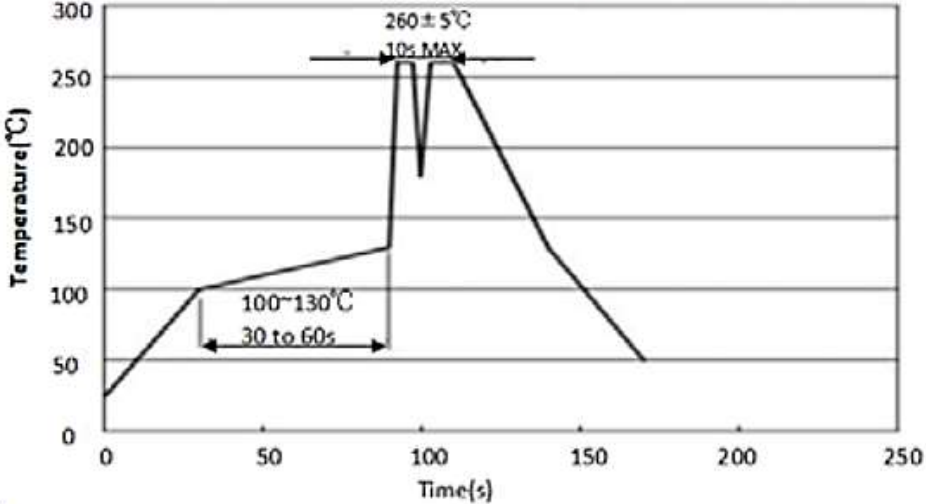
ITEM	PERFORMANCE
Welding condition	<p>The recommendation soldering conditions of the product in which flow soldering is possible are as graph</p> <div style="text-align: center;"> <p>Recommended flow soldering profile (PCB Undersurface temperature)</p>  </div> <p>Pay attention when welding :</p> <ul style="list-style-type: none"> • Do not dip the capacitor into melted solder ; • Do not touch other part except the terminals ; • If there is a direct contact between the sleeve of the capacitor and the printed circuit pattern or a metal part of another component such as a lead wire, it may cause shrinkage of crack ; • If the application is for extended use, understand and manage the soldering characteristics firstly to avoid abnormal current caused by a contact failure between the capacitor and the PCB ; • Please refer to product specifications about other notes.

ELECTRIC DOUBLE LAYER CAPACITORS EM SERIES**APPLICATION GUIDELINES****Life Time**

Electric Double Layer Capacitors (EDLC) has a longer life time than secondary batteries, but their life time is not infinite. The basic end-of life failure mode for an EDLC is an increase in equivalent series resistance (ESR) and/or a decrease in capacitance. The actual end-of-life criteria are dependent on the application requirements. Prolonged exposure to elevated temperatures, high applied voltage and excessive current will lead to increased ESR and decreased capacitance. Reducing these parameters will lengthen the life time of a supercapacitor. In general, cylindrical EDLC have a similar construction to electrolytic capacitors, they have a liquid electrolyte inside an aluminum can sealed with a rubber bung. Over many years, the EDLC will dry out, similar to an electrolytic capacitor, causing an increase in ESR and eventually end-of-life.

Voltage

EDLC are rated with a nominal recommended working or applied voltage. The values provided are set for long life at their maximum rated temperature. If the applied voltage exceeds the recommended voltage, the life time will be reduced. If the applied voltage is excessive for a prolonged time period, gas generation will occur inside the EDLC and may result in leakage or rupture of the safety vent. However, short-term over voltage can usually be tolerated by the EDLC.

Polarity

EDLC are designed with symmetrical electrodes, meaning they are similar in composition. When an EDLC is first assembled, either electrode can be designated positive or negative. Once the EDLC is charged for the first time during the 100% QA testing operation, the electrodes become polarized. Every EDLC has a negative stripe or sign denoting polarity. Although they can be shorted to zero volts, the electrodes maintain a very small amount of charge. Reversing polarity is not recommended, however previously charged EDLC have been discharged to $-2.5V$ with no measurable difference in capacitance or ESR.

Note: The longer they are held charged in one direction, the more polarized they become. If reversely charged after prolonged charging in one direction, the life of the EDLC may be shortened

ELECTRIC DOUBLE LAYER CAPACITORS EM SERIES

APPLICATION GUIDELINES

Ambient Temperature

Temperature in combination with voltage can affect the life time of an EDLC. In general, raising the ambient temperature by 10°C will decrease the life time of an EDLC by a factor of two. As a result, it is recommended to use the EDLC at the lowest temperature possible to decrease internal degradation and ESR increase.

At temperature lower than normal room temperature, it is possible to apply voltages slightly higher than the recommended working voltage without significant increase in degradation and reduction in life time.

Raising the applied voltage at low temperatures can be useful to offset the increased ESR. Increased ESR at higher temperatures will result in permanent degradation/electrolyte decomposition inside the EDLC. At low temperatures, however, increased ESR is only a temporary phenomenon due to the increased viscosity of the electrolyte and slower movement of the ions..

Discharge Characteristics

EDLC discharges with a sloping voltage curve. When determining the capacitance and ESR requirements for an application, it is important to consider both the resistive and capacitive discharge components. In high current pulse applications, the resistive component is the most critical. In low current and long duration applications, the capacitive discharge component is the most critical. The formula for the voltage drop, V_{drop} , during a discharge at I current for t seconds is: $V_{drop} = I (R+t/C)$

To minimize voltage drop in a pulse application, use an EDLC with low ESR (R value).

To minimize voltage drop in a low current application, use an EDLC with large capacitance (C value).

ELECTRIC DOUBLE LAYER CAPACITORS EM SERIES

APPLICATION GUIDELINES

Self Discharge and Leakage Current

Self discharge and leakage current are essentially the same thing measured in different ways. Due to the EDLC construction, there is a high-resistance internal current path from the anode to the cathode. This means that in order to maintain the charge on the capacitor a small amount of additional current is required. During charging this is referred to as leakage current. When the charging voltage is removed, and the capacitor is not loaded, this additional current will urge the EDLC to discharge and is referred to as the self discharge current.

In order to get a realistic measurement of leakage or self discharge current the EDLC must be charged for an excess of 100 hours. This is also due to the capacitor construction. The EDLC can be modeled as several capacitors connected in parallel, each with an increasing value of series resistance. The capacitors with low values of series resistance are charged quickly thus increasing the terminal voltage to the same level as the charge voltage. However, if the charge voltage is removed these capacitors will discharge into the parallel capacitors with higher series resistance if they are not fully charged. The result of this is that the terminal voltage will fall, giving the impression of high self discharge current. It should be noted that the higher the capacitance value is, the longer it will take for the device to be fully charged.

ELECTRIC DOUBLE LAYER CAPACITORS EM SERIES**APPLICATION GUIDELINES****Series Configurations of EDLC**

As many applications require higher voltages, EDLC can be configured in series to increase the working voltage.

It is important to ensure that the individual voltage of any single EDLC does not exceed its maximum recommended working voltage as this will result in electrolyte decomposition, gas generation, increased ESR and reduced life time.

$$V_{cap2} = V_{supply} \times (C_{cap1} / (C_{cap1} + C_{cap2}))$$

$$V_{cap2} = 5V \times (1.2 / (1.2 + 0.8)) = 3V$$

Capacitor voltage imbalance is caused, during charge and discharge, by differences in capacitance value and, in steady state, by differences in capacitor leakage current. During charging, series connected capacitors will act as a voltage divider so higher capacitance devices will receive greater voltage stress. For example, if two 1F capacitors are connected in series, one at +20% of nominal capacitance, the other at -20%, the worst-case voltage across the capacitors is given by:

$$V_{cap2} = V_{supply} \times (C_{cap1} / (C_{cap1} + C_{cap2}))$$

where Ccap1 has the +20% capacitance.

So for a V supply = 5V,

$$V_{cap2} = 5V \times (1.2 / (1.2 + 0.8)) = 3V$$

From above, it can be seen that in order to avoid exceeding the EDLC surge voltage rating of 3V, the capacitance values of series connected parts must fall in a ±20% tolerance range. Alternatively a suitable active voltage balancing circuit can be employed to reduce voltage imbalance due to capacitance mismatch.

It should be noted that the most appropriate method of voltage balancing depends on the specific application.

ELECTRIC DOUBLE LAYER CAPACITORS EM SERIES

APPLICATION GUIDELINES

Passive Voltage Balancing

Passive voltage balancing uses voltage-dividing resistors in parallel with each EDLC. This allows current to flow from the EDLC at a higher voltage level into the EDLC at a lower voltage level, thus balancing the voltage.

It is important to choose balancing resistors values that provide for higher current flow than the anticipated leakage current of the EDLC, bearing in mind that the leakage current will increase at higher temperatures.

Passive voltage balancing is only recommended for applications that don't regularly charge and discharge the EDLC and that can tolerate the additional load current of the balancing resistors. It is suggested that the balancing resistors be selected to give additional current flow of at least 50 times the worst-case EDLC leakage current (3.3k Ω to 22k Ω depending on maximum operating temperature). Although higher values of balancing resistors will work in most cases they are unlikely to provide adequate protection when significantly mismatched parts are connected in series.

Active Voltage Balancing

Active voltage balancing circuits force the voltage at the nodes of series connected EDLC to be the same as a fixed reference voltage, regardless of how many voltage imbalances occur. To ensure accurate voltage balancing, active circuits typically draw much lower levels of current in steady state and only require larger currents when the capacitor voltage goes out of balance. These characteristics make active voltage balancing circuits ideal for applications that charge and discharge the EDLC frequently as well as those with a finite energy source such as a battery.

Reverse Voltage Protection

When series connected EDLC are rapidly discharged, the voltage on low capacitance value parts can potentially become negative. As explained previously, this is not desirable and can reduce the operating life of the EDLC. One simple way of protecting reverse voltage is to add a diode across the capacitor, configured so that it is normally reverse bias. By using a suitably rated zener diode in place of a standard diode the EDLC can also be protected against overvoltage events. Care must be taken to ensure that the diode can withstand the available peak current from the power source

ELECTRIC DOUBLE LAYER CAPACITORS EM SERIES

APPLICATION GUIDELINES

Soldering Information

Excessive heat may cause deterioration of the electrical characteristics of the EDLC, electrolyte leakage or an increase in internal pressure. Follow the specific instructions listed as below:

- Do not dip EDLC body into melted solder.
- Only flux the leads of the EDLC.
- Ensure that there is no direct contact between the sleeve of the EDLC and the PC board or any other component. Excessive solder temperature may cause sleeve to shrink or crack.
- Avoid exposed circuit board runs under the EDLC to prevent electrical shorts.

Manual Soldering

Do not touch the EDLC’s external sleeve with the soldering rod, or the sleeve will melt or crack. The recommended temperature of the soldering rod tip is less than 350°C and the soldering duration should be less than 4 seconds. Minimize the time that the soldering iron is in direct contact with the terminals of the EDLC, as excessive heating of the leads may lead to higher equivalent series resistance (ESR).

Wave Soldering

Use a maximum preheating time of 60 seconds for PC boards 0.8mm or thicker. Preheating temperature should be limited to less than 100°C. Use the following table for wave soldering on leads only:

Solder Bath Temperature (°C)	Recommended Solder Exposure (seconds)	Max. Solder Exposure (Seconds)
220	7	9
240	7	9
250	5	7
260	3	5

ELECTRIC DOUBLE LAYER CAPACITORS EM SERIES

APPLICATION GUIDELINES

Ripple Current

EDLC have a very low resistance compared to other supercapacitors but have a higher resistance than aluminum electrolytic capacitors. EDLC are more susceptible to internal heat generation when exposed to ripple current. In order to ensure long life time, the maximum ripple current recommended should not increase the surface temperature of the EDLC by more than 3°C, as heat generation leads to electrolyte decomposition, gas generation, increased ESR and reduced life time.

Circuit Board Design

Cleaning of the circuit board should be avoided. If the circuit board must be cleaned use static or ultrasonic immersion in a standard circuit board cleaning fluid for no more than 5 minutes and a maximum temperature of +60°C. Afterwards thoroughly rinse and dry the circuit boards. In general, treat EDLC in the same manner you would an aluminum electrolytic capacitor.

Long Term Storage

Do not store EDLC in any of the following environments:

- High temperature and/or high humidity
- Direct contact with water, salt water, oil or other chemicals
- Direct contact with corrosive materials, acids, alkalis or toxic gases
- Direct exposure to sunlight
- Dusty environment
- Environment subject to excessive shock and/or vibration

ELECTRIC DOUBLE LAYER CAPACITORS EM SERIES

APPLICATION GUIDELINES

Thermal Performance

Low internal resistance of the energy storage units enables low heat generation within the units during use.

As with any electronic components, the cooler the operating environment the longer the service life. In most applications, natural air convection should provide adequate cooling. In severe application requiring maximum service life some forced airflow may be required.

The thermal resistance, R_{th} of the units have been experimentally determined assuming free convection at ambient temperature (-25°C). The R_{th} value provided on the data sheet is useful for determining the operating limits for the units. Using the R_{th} value, a module temperature rise can be determined based upon any current and duty cycle.

The temperature rise can be expressed by the following equation:

$$\Delta T = Dc \cdot R_{th} \cdot I^2 \cdot R_{esr}$$

where Dc = Duty Cycle

R_{th} = Thermal Resistance ($^{\circ}\text{C}/\text{W}$)

I = Current AC or DC (A)

R_{esr} = Equivalent Series Resistance, (Ohms) (dc value used)

This temperature rise, ΔT , plus ambient temperature should remain below the specified maximum operating temperature for the EDLC. If forced cooling methods are employed, it is possible to operate the units at higher currents or duty cycles.

Features

- Can be used as a rechargeable battery and ideal for back up purposes.
- Capable of several hundreds of thousands of charge/discharge cycles; free from throwaway disposal.
- Does not contain toxic materials such as nickel and cadmium.

ELECTRIC DOUBLE LAYER CAPACITORS EM SERIES

APPLICATION GUIDELINES

Emergency Procedures

If an EDLC is found to be overheating or if you smell a sweet odor, immediately disconnect any power or load to the EDLC. Allow the EDLC to cool down, then dispose it properly. Do not expose your face or hands to an overheating EDLC. Contact the factory for a Material Safety Data Sheet if an EDLC leaks or vents.

If exposed to electrolyte:

- Skin Contact: Wash exposed area thoroughly with soap and water.
- Eye Contact: Rinse eyes with water for 15 minutes and seek medical attention.
- Ingestion: Drink milk/water and induce vomiting; seek medical attention.

General Safety Considerations

EDLC may vent or rupture if overcharged, reverse charged, incinerated or heated above 150°C. Do not crush, mutilate, nail penetrate or disassemble. High case temperature (burn hazard) may result from abuse of EDLC.

Disposal Procedures: Do not dispose of unit in trash. Dispose of according to local regulations.

RoHS Compliance:

The levels of RoHS restricted materials in this product are below the maximum concentration values (also referred to as the threshold limits) permitted for such substances, or are used in an exempted application, in accordance with EU RoHS Directive (EU) 2015/863 EC (RoHS3). RoHS Test Report for this product can be obtained at Download Center.

REACH Compliance:

REACH substances of high concern (SVHCs) information is available for this product. Since the European Chemical Agency (ECHA) has published notice of their intent to frequently revise the SVHC listing for the foreseeable future, REACH Test Report for this product can be obtained at Download Center.

ELECTRIC DOUBLE LAYER CAPACITORS EM SERIES

IMPORTANT NOTES AND DISCLAIMER

1. All Product parametric performance is indicated in the Electrical Characteristics for the listed herein test conditions, unless otherwise noted. Product performance may not be indicated by the Electrical Characteristics if operated under different conditions.
2. NextGen Component, Inc (*NextGen*) reserves the right to make changes to this document and its products and specifications at any time without notice. Customers should obtain and confirm the latest product information and specifications before final design, purchase or use.
3. *NextGen* makes no warranty, representation or guarantee regarding the suitability of its products for any particular purpose, not does NextGen assume any liability for application assistance or customer product design.
4. *NextGen* does not warrant or accept any liability with products which are purchased or used for any unintended or unauthorized application. No license is granted by implication or otherwise under any intellectual property rights of *NextGen*.
5. *NextGen* products are not authorized for use as critical components in life support devices or systems without express written approval by *NextGen*.
6. *NextGen* requires that customers first obtain an RMA (Returned Merchandise Authorization) number prior to returning any products. Returns must be made within 30 days of the date of invoice, be in the original packaging, unused and like-new condition. At the time of quoting or purchasing, a product may say that it is Non-Cancelable/ Non-Returnable (NCNR). These products are not returnable and not refundable.