



**SPECIFICATION SHEET**

<b>SPECIFICATION SHEET NO.</b>	Q1226-MMSZ5221BS00C1	
<b>DATE</b>	Dec. 26, 2023	
<b>REVISION</b>	A0	Updated With Most Recent Data - Official First Release
<b>DESCRIPTION AND MAIN PARAMETRICS</b>	<p>SMD Zener Diodes, MMSZ series, Case SOD-123, 2 Pads  MMSZ5221B Type,  Voltage - Zener (Nom) (Vz): 2.4V, Power Dissipation: 0.5 Watts  Junction temperature: +150°C  Package in Tape/Reel, 3000pcs/Reel  RoHS/RoHS III compliant, RoHS Annex III lead Exemption  (Exempt per RoHS EU 2015/863)</p>	
<b>CUSTOMER</b>		
<b>CUSTOMER PART NO.</b>		
<b>CROSS REF. PART NO.</b>		
<b>ORIGINAL MFG/PART NO.</b>	MDD Diodes/MMSZ5221B	
<b>PART CODE</b>	MMSZ5221BS00C1	

<b>VENDOR APPROVE</b>		
Issued/Checked/Approved		
		
DATE: Dec. 26, 2023		

<b>CUSTOMER APPROVE</b>	
DATE:	

**SMD ZENER DIODES CASE SOD-123 MMSZ SERIES**

**MAIN FEATURE**

- Small Plastic Package Suitable For Surface Mounted Design.
- Wide Zener Reverse Voltage Range 2.4V To 43V.
- Glass Passivated Junction
- Tolerance Approximately  $\pm 5\%$
- 0.5W Max. Peak Pulse Power
- High Temperature Soldering Guaranteed: 260°C/10 Seconds At Terminals
- RoHS/RoHS III compliant, RoHS Annex III lead Exemption (Exempt per RoHS EU 2015/863)
- Cross Main Competitor Parts In Market



**APPLICATION**

- For SMD Application

**PART CODE GUIDE**

**RFQ**  
Request For Quotation

MMSZ	5221B	S	00C1
1	2	3	4

1. MMSZ: SMD Zener Diodes, MMSZ series Code, Package Case SOD-123
2. 5221B: Specification code for Voltage - Zener (Nom) (Vz): 2.4V
3. S: Package Code, Tape/Reel
4. 00C1: Internal Control Code Or Special Parameters Code, Letter A~Z Or Digits (1-9); Blank: N/A

**ELECTRICAL CHARACTERISTICS**

See Page 5 ~ Page 6 For Different Part Code

**HOW TO ORDER**

Please indicate part code and send us your RFQ by E-mail, [sales@nextgencomponent.com](mailto:sales@nextgencomponent.com)

**SMD ZENER DIODES CASE SOD-123 MMSZ SERIES**

**DIMENSION** - Unit: Inch/mm

Image for reference



**Marking:** Standard

- See Marking Code
- List at Page 5~ Page 6

**Case Dimension:**  
SOD-123

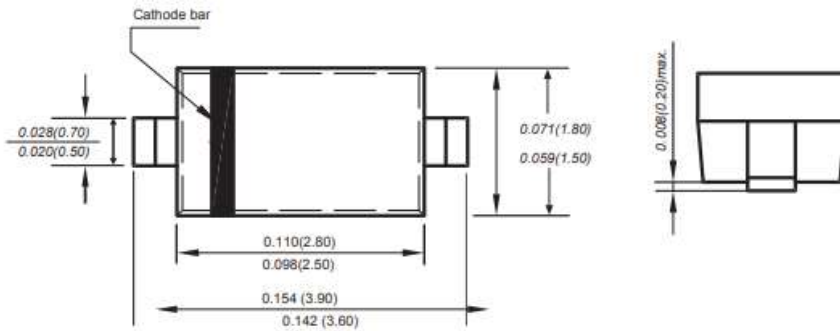

**Recommend Pad Layout**

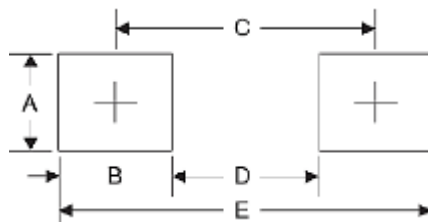

SYMBOL	UNIT (INCH)	UNIT (MM)
A	0.047	1.20
B	0.047	1.20
C	0.126	3.20
D	0.079	2.00
E	0.173	4.40

**SMD ZENER DIODES CASE SOD-123 MMSZ SERIES**

**MECHANICAL DATA**

CASE	TERMINALS	POLARITY	MOUNTING POSITION	MARKING	WEIGHT PER PIECE
JEDEC SOD-123 molded plastic body	Solderable per MIL-STD-750, Method 2026	Polarity symbol marking on body	ANY	See Marking Code List (Page 5~Page 6)	0.00056 ounce 0.016 grams

**MAX. RATING & CHARACTERISTICS** - Ratings at 25°C Ambient Temperature Unless Otherwise Specified.

PARAMETER	SYMBOLS	VALUE	UNITS
Forward Voltage @ I <sub>F</sub> =10mA	V <sub>F</sub>	0.9	V
Power Dissipation	P <sub>d</sub>	0.5	W
Thermal resistance, junction to ambient air	R <sub>θJA</sub>	350	°C/W
Junction Temperature	T <sub>J</sub>	+150	°C
Storage Temperature Range	T <sub>stg</sub>	-65 ~ +150	°C

Notes

1. Device mounted on ceramic PCB; 7.6 mm x 9.4 mm x 0.87 mm with pad areas 25 mm<sup>2</sup>.
2. Tested with pulses, T<sub>p</sub> ≤1.0ms.

**SMD ZENER DIODES CASE SOD-123 MMSZ SERIES**
**ELECTRICAL CHARACTERISTICS - Ta = 25°C**

Part Code	Zener Voltage Range Vz @ IZT			Test Current IZT (mA)	Max. Reverse Leakage Current		Max. Zener Impedance		Marking Code
	Nom. (V)	Min. (V)	Max. (V)		IR (µA)	@ VR (V)	ZzT@ IZT (Ω)	Zzk@ Izk=0.25 mA (Ω)	
MMSZ5221BS00C1	2.4	2.28	2.52	20	100	1.0	30	1200	C1
MMSZ5223BS00C3	2.7	2.57	2.84	20	75	1.0	30	1300	C3
MMSZ5225BS00C5	3.0	2.85	3.15	20	50	1.0	30	1600	C5
MMSZ5226BS00G1	3.3	3.14	3.47	20	25	1.0	28	1600	G1
MMSZ5227BS00G2	3.6	3.42	3.78	20	15	1.0	24	1700	G2
MMSZ5228BS00G3	3.9	3.71	4.10	20	10	1.0	23	1900	G3
MMSZ5229BS00G4	4.3	4.09	4.52	20	5.0	1.0	22	2000	G4
MMSZ5230BS00G5	4.7	4.47	4.94	20	5.0	2.0	19	1900	G5
MMSZ5231BS00E1	5.1	4.85	5.36	20	5.0	2.0	17	1600	E1
MMSZ5232BS00E2	5.6	5.32	5.88	20	5.0	3.0	11	1600	E2
MMSZ5233BS00E3	6.0	5.70	6.30	20	5.0	3.5	7	1600	E3
MMSZ5234BS00E4	6.2	5.89	6.51	20	5.0	4.0	7	1000	E4
MMSZ5235BS00E5	6.8	6.46	7.14	20	3.0	5.0	5	750	E5
MMSZ5236BS00F1	7.5	7.13	7.88	20	3.0	6.0	6	500	F1
MMSZ5237BS00F2	8.2	7.79	8.61	20	3.0	6.5	8	500	F2
MMSZ5238BS00F3	8.7	8.27	9.14	20	3.0	6.5	8	600	F3
MMSZ5239BS00F4	9.1	8.65	9.56	20	3.0	7.0	10	600	F4
MMSZ5240BS00F5	10	9.50	10.50	20	3.0	8.0	17	600	F5
MMSZ5241BS00H1	11	10.45	11.55	20	2.0	8.4	22	600	H1
MMSZ5242BS00H2	12	11.40	12.60	20	1.0	9.1	30	600	H2

**SMD ZENER DIODES CASE SOD-123 MMSZ SERIES**
**ELECTRICAL CHARACTERISTICS - Ta = 25°C**

Part Code	Zener Voltage Range Vz @ IZT			Test Current IZT (mA)	Max. Reverse Leakage Current		Max. Zener Impedance		Marking Code
	Nom. (V)	Min. (V)	Max. (V)		IR ( $\mu$ A)	@ VR (V)	ZzT@ IZT ( $\Omega$ )	Zzk@ Izk=0.25 mA ( $\Omega$ )	
MMSZ5243BS00H3	13	12.35	13.65	9.5	0.5	9.9	13	600	H3
MMSZ5245BS00H5	15	14.25	15.75	8.5	0.1	11	16	600	H5
MMSZ5246BS00J1	16	15.20	16.80	7.8	0.1	12	17	600	J1
MMSZ5248BS00J3	18	17.10	18.90	7.0	0.1	14	21	600	J3
MMSZ5250BS00J5	20	19.00	21.00	6.2	0.1	15	25	600	J5
MMSZ5251BS00K1	22	20.90	23.10	5.6	0.1	17	29	600	K1
MMSZ5252BS00K2	24	22.80	25.20	5.2	0.1	18	33	600	K2
MMSZ5254BS00K4	27	25.65	28.35	5.0	0.1	21	41	600	K4
MMSZ5255BS00K5	28	26.60	29.40	4.5	0.1	21	44	600	K5
MMSZ5256BS00M1	30	28.50	31.5	4.2	0.1	23	49	600	M1
MMSZ5257BS00M2	33	31.35	34.65	3.8	0.1	25	58	700	M2
MMSZ5258BS00M3	36	34.20	37.80	3.4	0.1	27	70	700	M3
MMSZ5259BS00M4	39	37.05	40.95	3.2	0.1	30	80	800	M4
MMSZ5260BS00M5	43	40.85	45.15	3.0	0.1	33	93	900	M5

**SMD ZENER DIODES CASE SOD-123 MMSZ SERIES**

**RATINGS AND CHARACTERISTIC CURVES** (For Reference Only) -  $T_a = 25^\circ\text{C}$  Unless Otherwise Specified

Figure 1. Power Dissipation vs Ambient Temperature Curve

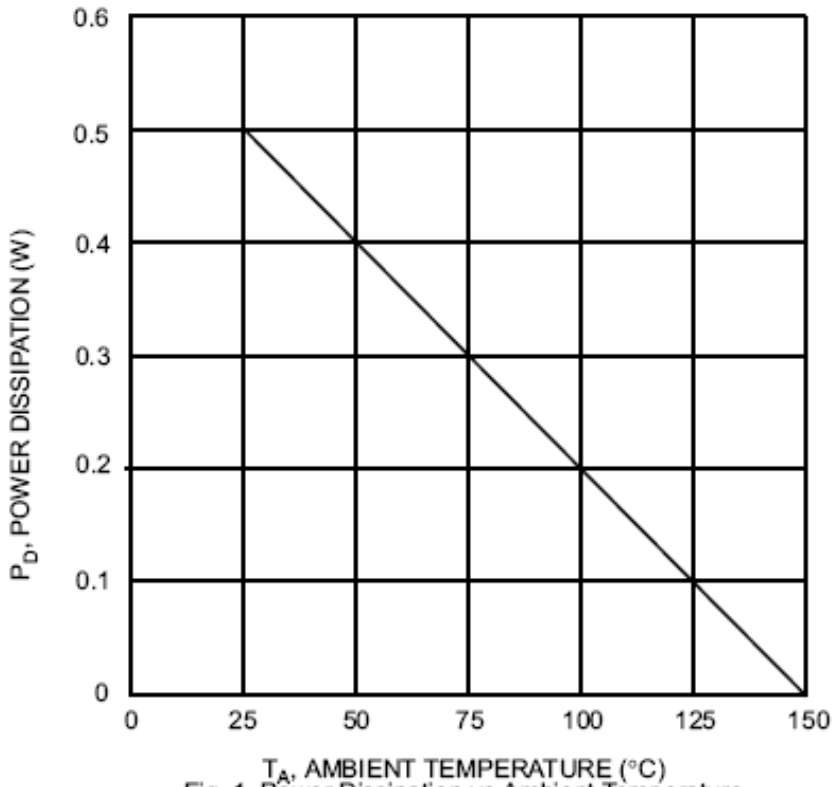

Fig. 1 Power Dissipation vs Ambient Temperature

**SMD ZENER DIODES CASE SOD-123 MMSZ SERIES**
**RELIABILITY**

NUMBER	EXPERIMENT ITEMS	EXPERIMENT METHOD AND CONDITIONS	REFERENCE DOCUMENTS
1	Solder Resistance Test	Test 260°C± 5°C for 10 ± 2 sec. Immerse body into solder 1/16" ± 1/32"	MIL-STD-750D METHOD-2031.2
2	Solderability Test	230°C ±5°C for 5 sec.	MIL-STD-750D METHOD-2026.1 0
3	Pull Test	1 kg in axial lead direction for 10 sec.	MIL-STD-750D METHOD-2036.4
4	Bend Test	0.5Kg Weight Applied To Each Lead, Bending Arcs 90 °C ± 5 °C For 3 Times	MIL-STD-750D METHOD-2036.4
5	High Temperature Reverse Bias Test	TA=100°C for 1000 Hours at VR=80% Rated VR	MIL-STD-750D METHOD-1038.4
6	Forward Operation Life Test	TA=25°C Rated Average Rectified Current	MIL-STD-750D METHOD-1027.3
7	Intermittent Operation Life Test	On state: 5 min with rated IRMS Power Off state: 5 min with Cool Forced Air. On and off for 1000 cycles.	MIL-STD-750D METHOD-1036.3
8	Pressure Cooker Test	15 PSIG, TA=121°C, 4 hours	MIL-S-19500 APPENIOXC
9	Temperature Cycling Test	-55°C~+125°C; 30 Minutes For Dwelled Time 5 minutes for transferred time. Total: 10 cycles.	MIL-STD-750D METHOD-1051.7
10	Thermal Shock Test	0°C for 5 minutes., 100°C for 5minutes, Total: 10 cycles	MIL-STD-750D METHOD-1056.7
11	Forward Surge Test	8.3ms Single Sale Sine-wave One Surge.	MIL-STD-750D METHOD-4066.4
12	Humidity Test	TA=65°C, RH=98% for 1000 hours.	MIL-STD-750D METHOD-1021.3
13	High Temperature Storage life Test	150°C for 1000 Hours	MIL-STD-750D METHOD-1031.5



**SMD ZENER DIODES CASE SOD-123 MMSZ SERIES**

**SUGGESTED REFLOW PROFILE - For Reference Only**

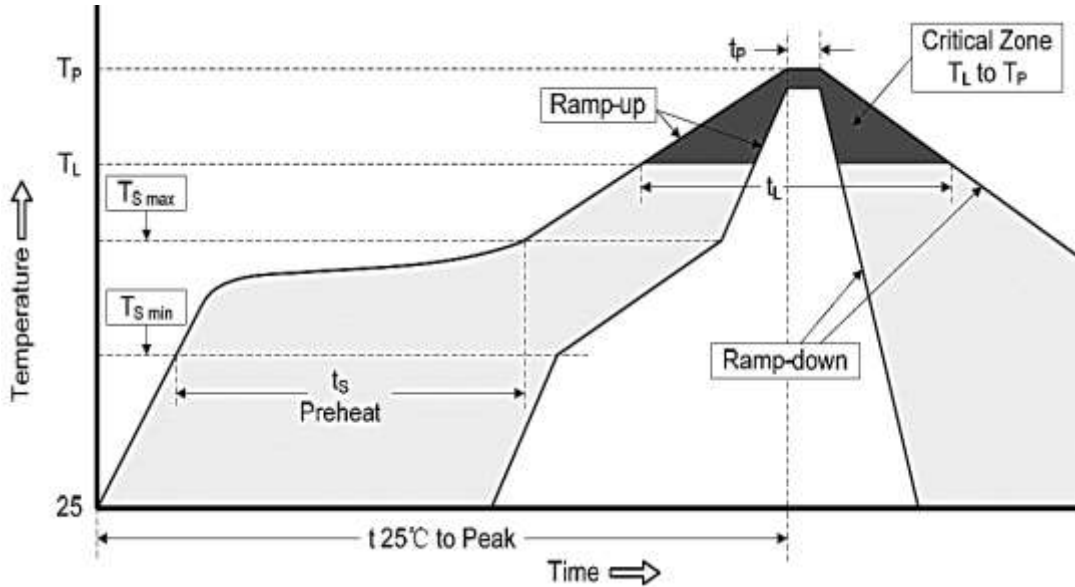

PROFILE FEATURE		PB-FREE ASSEMBLY
Average Ramp-up Rate ( $T_S$ Max to $T_P$ )		3°C/second Max
Preheat	Temperature Min ( $T_S$ Min.)	150°C
	Temperature Max ( $T_S$ Max.)	200°C
	Time ( $t_s$ Min. to $t_s$ Max.)	60 ~ 180 seconds
Time maintained above	Temperature ( $T_L$ )	217°C
	Time ( $t_l$ )	60 ~ 150 seconds
Peak/Classification Temperature ( $T_P$ )		260 °C
Time within 5°C of actual Peak Temperature ( $t_p$ )		20 ~ 40 seconds
Ramp-down rate		6 °C /Second Max.
Time 25 °C to Peak Temperature		8 minutes Max.
Suggest reflow times		3 Times Max.

**SMD ZENER DIODES CASE SOD-123 MMSZ SERIES**

**TAPE/REEL** (Unit: mm) - All Devices are packed in accordance with EIA standard RS-481-A.

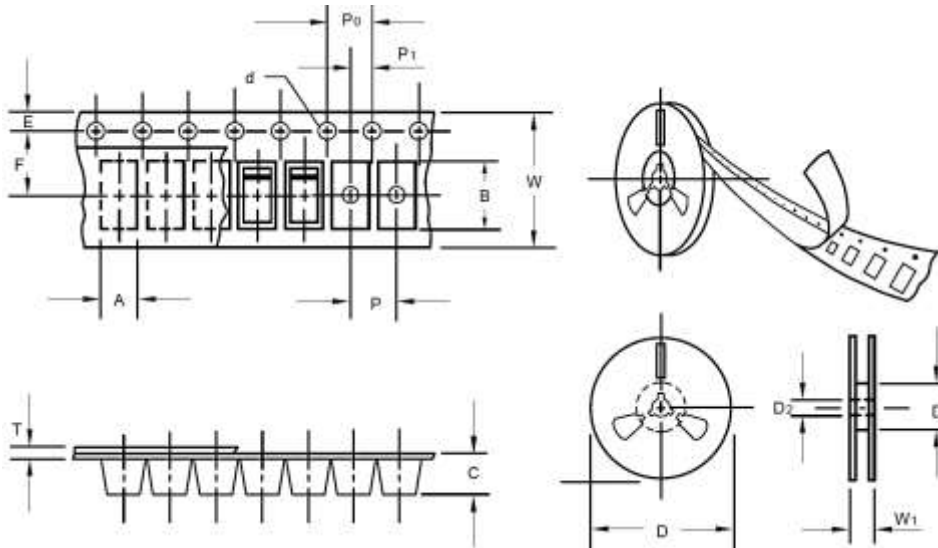

ITEM	SYMBOL	TOLERANCE	CASE SOD-123
Carrier width	A	0.1	2.10
Carrier Length	B	0.1	4.00
Carrier Depth	C	0.1	1.60
Sprocket hole	d	0.05	1.55
13" Reel outside diameter	-	-	-
13" Reel inner diameter	-	-	-
7" Reel outside diameter	D	2.0	178.00
7" Reel inner diameter	D1	Min.	50.00
Feed hole diameter	D2	0.5	13.00
Sprocket hole position	E	0.1	1.75
Punch hole position	F	0.1	3.50
Punch hole pitch	P	0.1	4.00
Sprocket hole pitch	P0	0.1	4.00
Embossment center	P1	0.1	2.00
Overall tape thickness	T	0.1	0.25
Tape width	W	0.3	8.15
Reel width	W1	1.0	10.50
Component Spacing	4.0		
Qty. Per Reel (pcs)	3000		

## SMD ZENER DIODES CASE SOD-123 MMSZ SERIES

### IMPORTANT NOTES AND DISCLAIMER

1. **ROHS COMPLIANCE:** The levels of RoHS restricted materials in this product are below the maximum concentration values (also referred to as the threshold limits) permitted for such substances, or are used in an exempted application, in accordance with EU RoHS Directive (EU) 2015/863 EC (RoHS3). RoHS Test Report for this product can be obtained at Download Center.
2. **REACH COMPLIANCE:** REACH substances of high concern (SVHCs) information is available for this product. Since the European Chemical Agency (ECHA) has published notice of their intent to frequently revise the SVHC listing for the foreseeable future, REACH Test Report for this product can be obtained at Download Center.
3. All Product parametric performance is indicated in the Electrical Characteristics for the listed herein test conditions, unless otherwise noted. Product performance may not be indicated by the Electrical Characteristics if operated under different conditions.
4. NextGen Component, Inc (*NextGen*) reserves the right to make changes to this document and its products and specifications at any time without notice. Customers should obtain and confirm the latest product information and specifications before final design, purchase or use.
5. *NextGen* makes no warranty, representation or guarantee regarding the suitability of its products for any particular purpose, not does *NextGen* assume any liability for application assistance or customer product design.
6. *NextGen* does not warrant or accept any liability with products which are purchased or used for any unintended or unauthorized application. No license is granted by implication or otherwise under any intellectual property rights of NextGen.
7. *NextGen* products are not authorized for use as critical components in life support devices or systems without express written approval by *NextGen*.
8. *NextGen* requires that customers first obtain an RMA (Returned Merchandise Authorization) number prior to returning any products. Returns must be made within 30 days of the date of invoice, be in the original packaging, unused and like-new condition. At the time of quoting or purchasing, a product may say that it is Non-Cancelable/ Non-Returnable (NCNR). These products are not returnable and not refundable.