

**SPECIFICATION SHEET**

<b>SPECIFICATION SHEET NO.</b>	R0806-DC455K0000S107	
<b>DATE</b>	Aug. 06, 2024	
<b>REVISION</b>	A2	Updated With Most Recent Data
<b>DESCRIPTION AND MAIN PARAMETRICS</b>	KHz SMD Discriminators 6260 Type L6.2*W6.0*H3.1mm 2 Pads DC Series 455KHz, Demodulated Bandwidth(3dB): $\pm 4.0$ KHz Min from 455KHz; Demodulated Output at 455KHz: 145 $\pm$ 40 mV Operating Temp. Range -20°C ~+85°C Reflow Profile Condition 260 °C Max. Tape/Reel, RoHS/RoHS III compliant, RoHS Annex III lead Exemption (exempt per RoHS EU 2015/863)	
<b>CUSTOMER</b>		
<b>CUSTOMER PART NO.</b>		
<b>CROSS REF. PART NO.</b>		
<b>ORIGINAL MFG/PART NO.</b>	TGS/CDBC 455C7 TLH/CDBC455C7	
<b>PART CODE</b>	DC455K0000S107	

**VENDOR APPROVE**

Issued/Checked/Approved



DATE: Aug. 06, 2024

**CUSTOMER APPROVE**

DATE:

8/6/2024

**KHZ SMD CERAMIC DISCRIMINATOR DC SERIES CASE 6260**

**MAIN FEATURE**

- KHz SMD Ceramic Discriminator 6260 Type 2 pads
- White case, L6.2\*W6.0\*H3.1mm
- Low Cost And Short Shipment
- Reflow Profile Condition 260 °C Max.
- Cross Main Competitors Parts CDBC and JTC series
- For Quadrature Detection With IC: MC3357
- REACH/RoHS/RoHS III compliant, RoHS Annex III lead Exemption (exempt per RoHS EU 2015/863)



**APPLICATION**

- Communication Electronics

**HOW TO ORDER**

- Please follow up Part Code Guide and Indicate Part Code When You Order Or RFQ.

**PART CODE GUIDE**

**RFQ**  
Request For Quotation

CODE	NAME	KEY SPECIFICATION OPTION
DC	Product Series Code	Part family Code for KHz SMD Ceramic Discriminator 6260 Type L6.2*W6.0*H3.1mm 2 Pads
455K	Frequency Range Code	450: 450KHz; 455K: 455KHz
0000	Internal Control Code	Letter or Digits (A~Z, a~z or 1~9)
S	SMD type Package Code	Tape/Reel
107	Specification Code	Letter or Digits (A~Z, a~z or 1~9) for Special Parametric

**KHZ SMD CERAMIC DISCRIMINATOR DC SERIES CASE 6260**

**DIMENSION** (Unit: mm)

Image for reference

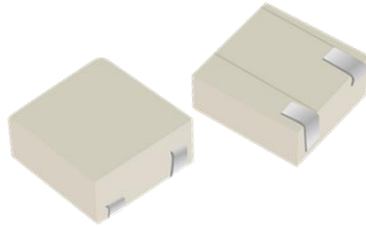

Case 6260 Type 2 Pads  
L6.2\*W6.0\*H3.1mm

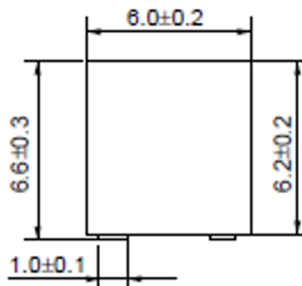

**Marking**

Line 1: CDBc

Line 2: 455C7

See Page 5/6 for different Part Code

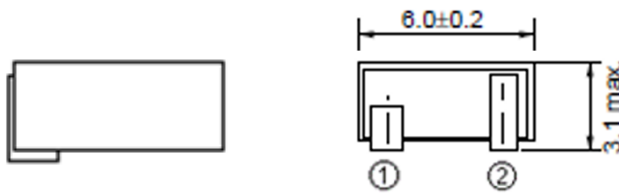

**Connection**

①: Pin 1: Input/Output

②: Pin 2: Output/Input

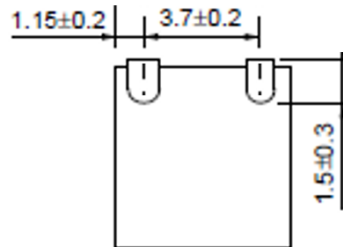

## KHZ SMD CERAMIC DISCRIMINATOR DC SERIES CASE 6260

### MATERIAL LIST

No.	Item	Material
1	Case	Polybutene Terephthalate (Mixture Of Glass Fiber)
2	Terminal	Phosphor Bronze Ag Clad
3	Base Seal	Epoxy Resin

### MEASUREMENT

- Measurement shall be carried out at the standard temperature of  $25 \pm 2^\circ\text{C}$ . If no specific requirements, Test can be carried out under  $5\text{-}35^\circ\text{C}$ .
- Measuring Circuit: For Quadrature Detection With IC MC3357

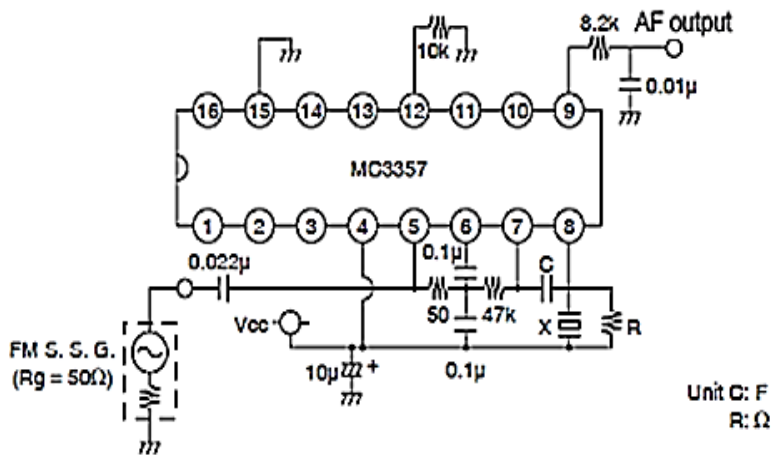

### GENERAL ELECTRICAL CHARACTERISTICS

PARAMETER	UNITS	VALUE			CONDITION
		MIN.	TYPICAL	MAX.	
Operation Temperature	$^\circ\text{C}$	-20		+85	
Storage Temperature	$^\circ\text{C}$	-40		+85	
Temperature Stability	%			$\pm 0.5$	@ $-20^\circ\text{C} \sim +85^\circ\text{C}$
Withstand Voltage	V	DC 50V For 1 minute			

**KHZ SMD CERAMIC DISCRIMINATOR DC SERIES CASE 6260**
**ELECTRICAL PARAMETERS – FOR DIFFERENT PART CODE- Ta = 25°C**

Part Code	Modulation Frequency	3dB Demodulated Bandwidth from 450 kHz	Demodulated Output at 450 kHz	Demodulated Distortion Factor	IC Model No. For Reference Only	Marking Line 2
	KHz	KHz	mV	%		
DC450K0000S024	450±1.0	±4.0KMin	100±40	2.0	TA31136F	450C24
DC450K0000S028	450±1.0	±4.0KMin	40±20	3.0	TA31142F	450C28
DC450K0000S036	450±1.0	±13.0Min	90±30	2.5	NE(SA) 606/616	450C36
DC450K0000S049	450±1.0	±4.0 Min	45±10	3.0	MC3661	450C49
DC450K0000S079	450±1.0	±4.0 Min	145±40	/	TB32302FG	450C79

**ELECTRICAL PARAMETERS – FOR DIFFERENT PART CODE- Ta = 25°C**

Part Code	Anti-Resonate Frequency	Resonant Impedance	$\Delta F(F_a - F_r)$ Fr: Resonant Frequency	Capacitance (at 1 kHz)	IC Model No. For Reference Only	Marking Line 2
	KHz	Ohm	mV	pF		
DC455K0000S103	455±1.0	70 Max.	46±5.0	550 ±20%	CXA1184M	455C3
DC455K0000S133	462±1.5	200 Max.	40±4.0	150 ±20%	CXA1474	455C33

**KHZ SMD CERAMIC DISCRIMINATOR DC SERIES CASE 6260**
**ELECTRICAL PARAMETERS – FOR DIFFERENT PART CODE- Ta = 25°C**

Part Code	Modulation Frequency	3dB Demodulated Bandwidth from 455 kHz	Demodulated Output at 455 kHz	Demodulated Distortion Factor	IC Model No. For Reference Only	Marking Line 2
	KHz	KHz	mV	%		
DC455K0000S107	455±1.0	±4.0 Min	350±60	3.0	MC3357	455C7
DC455K0000S109	455±1.0	±4.0 Min	120±40	1.5	NE604N	455C9
DC455K0000S113	455±1.0	±4.0 Min	330±50	4.0	CXA1003BM	455C13
DC455K0000S116	455±1.0	±4.0 Min	175±40	2.0	MC3372	455C16
DC455K0000S124	455±1.0	±4.0 Min	100±40	2.0	TA31136FN	455C24
DC455K0000S127	455±1.0	±4.0 Min	90±30	2.0	TK10487	455C27
DC455K0000S128	455±1.0	±4.0 Min	48~51	3.0	TA31142F	455C28
DC455K0000S129	455±1.0	±4.0 Min	100±30	2.5	NE605	455C29
DC455K0000S132	455±1.0	±4.0 Min	40±20	3.0	TA31142F	455C32
DC455K0000S135	455±1.0	±4.0 Min	100±40	2.5	TK10930	455C35
DC455K0000S136	455±1.0	±13.0 Min	90±30	2.5	NE(SA) 606/616	455C36
DC455K0000S139	455±1.0	±11.0 Min	130±20	2.5	NE(SA) 607/617	455C39
DC455K0000S140	455±1.0	±4.0 Min	40±20	3.5	TA31145	455C40
DC455K0000S149	455±1.0	±4.0 Min	45±10	3.0	MC3361	455C49
DC455K0000S150	455±1.0	±4.0 Min	64±6.4	4.0	CXA3117	455C50
DC455K0000S154	455±1.0	±4.0 Min	165±20	/	TA31149	455C54
DC455K0000S166	455±1.0	±4.2 Min	40±10	4.0	NJM2590	455C66
DC455K0000S170	455±1.0	±5.0 Min	85±10	4.5	NJM2591V	455C70
DC455K0000S179	455±1.0	±3.0 Min	145±40	/	TB32302FG	455C79

**KHZ SMD CERAMIC DISCRIMINATOR DC SERIES CASE 6260**

**TEST METHOD AND CONDITIONS**

Measurement Condition: Unless otherwise noted, the standard range of atmospheric conditions for measurements and tests are as follows:

Ambient temperature: 5°C to 35 °C Relative humidity :45% to 85%; Air pressure :86Kpa to 106 Kpa

If there is doubt about the results, measurement shall be made within the following limits:

Ambient temperature: 18°C to 22 °C ; Relative humidity :60% to 70%; Air pressure: 86Kpa to 106 Kpa

TEST ITEMS	TEST METHOD AND CONDITIONS	REQUIREMENT
Demodulated 3dB Bandwidth	Input the above signal and sweep the carrier around 450kHz, and find Out the maximum audio output frequency. Then sweep the carrier frequency again and find two frequencies, which are observed –3dB attenuation points from the maximum point. Higher frequency point is called (f1) and lower called (f2). (F1-455KHz) is defined as upper 3dB bandwidth and (455KHz -f2) defined as lower 3dB bandwidth.	No visible damage and it meet Table at Page 5/6
Demodulate Output	Demodulated output shall be measured when carrier frequency is adjusted to 455KHz.	No damage and it meet Table at Page 5/6
Demodulated Distortion Factor	Carrier frequency is adjusted to 455KHz And distortion shall be measured with 1 kHz modulation frequency.	No damage and it meet Table at Page 5/6.
Input Signal Condition	Input signal condition, Input level 80dBμ; Frequency Deviation ±4.0 kHz; Modulation Frequency: 1.0KHz	

**KHZ SMD CERAMIC DISCRIMINATOR DC SERIES CASE 6260**

**ENVIRONMENTAL CHARACTERISTICS**

TEST ITEMS	MEASUREMENT CONDITION	REQUIREMENT
Humidity	After being placed in a chamber with 90-95% R.H. at 40±2°C for 100 hours and then being placed in room temperature for 1 hour, filter shall be measured.	It shall meet Table at Page 5/6
High Temperature	After being placed in a chamber with 80±2°C, for 100 hours and then being placed in room temperature for 1 hour, filter shall be measured.	It shall meet Table at Page 5/6
Low Temperature	After being placed in a chamber with -20±2°C, for 100 hours and then being placed in room temperature for 1 hour, filter shall be measured.	It shall meet Table at Page 5/6
Heat Shock	After being kept at room temperature, filter shall be placed at temperature of -55 °C, for 30 minutes, then be placed at temperature. 85°C, for 30 minutes. After that returned to -55°C again. Repeated above cycle for 5 times. After being kept in room temp. for 1 hour, filter shall be measured	It shall meet Table at Page 5/6
Resistance to Solder Heat	Lead terminals are immersed up to 1.5mm from filter’s body in soldering bath of 350± 10°C, for 3±0.5 sec. And then filter shall be measured after being placed in room temperature for 1 hour.	It shall meet Table at Page 5/6



**KHZ SMD CERAMIC DISCRIMINATOR DC SERIES CASE 6260**

**PHYSICAL CHARACTERISTICS**

TEST ITEMS	TEST METHOD AND CONDITIONS	REQUIREMENT
Random Drop/ Drop Test	Filter shall be measured after 3 times random drops from the height of 30cm on concrete floor	No damage and it meet Table at Page 5/6
Vibration	Filter shall be measured after being applied vibration of amplitude of 1.5mm with 10-55Hz band of vibration frequency to each of 3 perpendicular directions for 2 hours	No damage and it meet Table at Page 5/6
Solderability	Lead terminals are immersed in aide solder for 5 sec and then immersed in soldering bath of 230±5°C, for 3±0.5 sec. At least 95% lead terminals shall be covered with solder	No damage and it meet Table at Page 5/6
Substrate Bending Test	After lead terminals shall be fixed at 2mm from filter's body, they shall be folded up to 90°from their axial directions and folded back to -90°.Then folded back to their axial direction, the speed of folding be each 3 seconds.	No damage and it meet Table at Page 5/6
Terminal Strength Pulling	After force of 1kg for 10 seconds is applied to each terminal in axial direction, Filter shall be measured.	No damage and it meet Table at Page 5/6

**KHZ SMD CERAMIC DISCRIMINATOR DC SERIES CASE 6260**

**SUGGESTED REFLOW PROFILE** (For Reference Only)

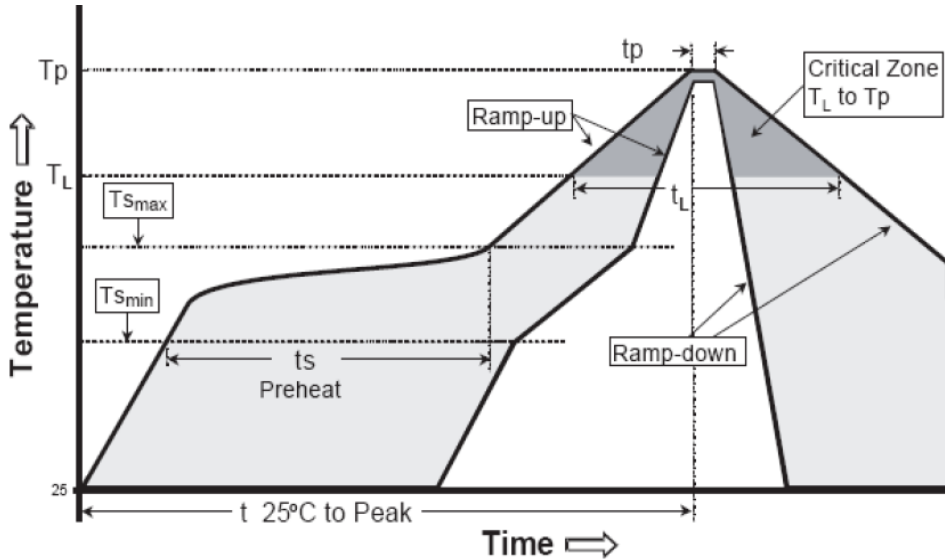

PROFILE FEATURE		PB-FREE ASSEMBLY
Average Ramp-up Rate ( $T_s$ Max to $T_p$ )		3°C/second Max
Preheat	Temperature Min ( $T_s$ Min.)	150°C
	Temperature Max ( $T_s$ Max.)	180°C
	Time ( $t_s$ Min. to $t_s$ Max.)	60 ~ 180 seconds
Time maintained above	Temperature ( $T_L$ )	230°C
	Time ( $t_L$ )	60 ~ 150 seconds
Peak/Classification Temperature ( $T_p$ )		260 °C
Time within 5°C of actual Peak Temperature ( $t_p$ )		20 ~ 40 seconds
Ramp-down rate		6 °C /Second Max.
Time 25 °C to Peak Temperature		8 minutes Max.
Suggest reflow times		3 Times Max.

**KHZ SMD CERAMIC DISCRIMINATOR DC SERIES CASE 6260**

**REEL AND TAPE DIMENSION** (Unit: mm, 2000pcs/Reel)

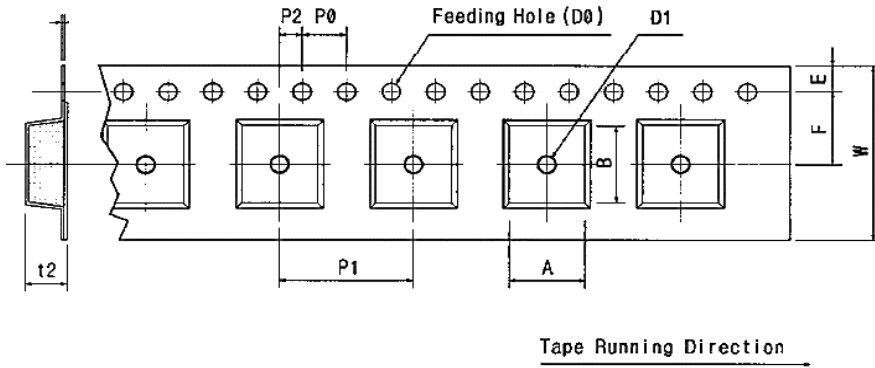

CODE	DIMENSION
W	16.0+/-0.30
F	6.80+/-0.20
E	1.75+/-0.10
P 0	4.00+/-0.10
P 1	7.80+/-0.10
P 2	2.00+/-0.05
D 0	Ø1.5+/-0.10
D 1	Ø1.5+/-0.10
t 2	3.60+/-0.10
A	7.70+/-0.10

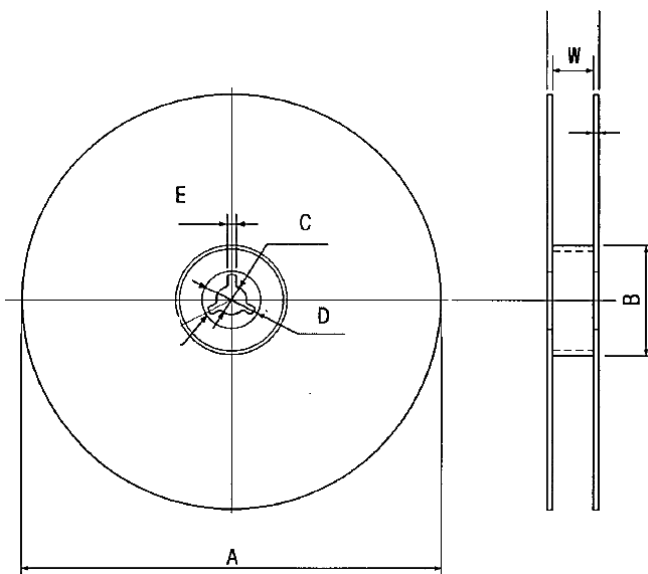

CODE	DIMENSION
A	Ø330+/-1.0
B	Ø80+/-0.5
C	Ø13.0+/-0.5
E	2.00+/-0.3
W	16.0+/-1.0

## KHZ SMD CERAMIC DISCRIMINATOR DC SERIES CASE 6260

### IMPORTANT NOTES AND DISCLAIMER

1. **ROHS COMPLIANCE:** The levels of RoHS restricted materials in this product are below the maximum concentration values (also referred to as the threshold limits) permitted for such substances, or are used in an exempted application, in accordance with EU RoHS Directive (EU) 2015/863 EC (RoHS3). RoHS Test Report for this product can be obtained at Download Center.
2. **REACH COMPLIANCE:** REACH substances of high concern (SVHCs) information is available for this product. Since the European Chemical Agency (ECHA) has published notice of their intent to frequently revise the SVHC listing for the foreseeable future, REACH Test Report for this product can be obtained at Download Center.
3. All Product parametric performance is indicated in the Electrical Characteristics for the listed herein test conditions, unless otherwise noted. Product performance may not be indicated by the Electrical Characteristics if operated under different conditions.
4. NextGen Component, Inc (*NextGen*) reserves the right to make changes to this document and its products and specifications at any time without notice. Customers should obtain and confirm the latest product information and specifications before final design, purchase or use.
5. *NextGen* makes no warranty, representation or guarantee regarding the suitability of its products for any particular purpose, not does *NextGen* assume any liability for application assistance or customer product design.
6. *NextGen* does not warrant or accept any liability with products which are purchased or used for any unintended or unauthorized application. No license is granted by implication or otherwise under any intellectual property rights of NextGen.
7. *NextGen* products are not authorized for use as critical components in life support devices or systems without express written approval by *NextGen*.
8. *NextGen* requires that customers first obtain an RMA (Returned Merchandise Authorization) number prior to returning any products. Returns must be made within 30 days of the date of invoice, be in the original packaging, unused and like-new condition. At the time of quoting or purchasing, a product may say that it is Non-Cancelable/ Non-Returnable (NCNR). These products are not returnable and not refundable.