



<b>SPECIFICATION SHEET NO.</b>	R1019- CD2M00000SF200	
<b>ORIGINAL MFG/PART NO</b>	TGS Crystals/CRTWS 2.0MGTLH- B25	
<b>DATE</b>	Oct. 19, 2024	
<b>REVISION</b>	A2	Updated With Most Recent Data
<b>DESCRIPTION AND MAIN PARAMETRICS</b>	<p>MHz Thru-Hole Ceramic Resonator, CD Series, 3 Pins, Lead Length: 13.5mm            Dimension L9.5*W4.0*H5.5mm            2.000MHz, Built-in Capacitance, 30pF; Frequency Accuracy <math>\pm 0.5\%</math>,            Operating Temp. Range <math>-25^{\circ}\text{C} \sim +85^{\circ}\text{C}</math>            Package in Tape and Box, 2000pcs/Paper Tape            RoHS/RoHS III Compliant, RoHS Annex III lead Exemption (Exempt per RoHS EU 2015/863)            REACH Compliant, The 233 Substances of Very High Concern, as specified by Regulation (EC) No.1907/2006.</p>	
<b>CUSTOMER</b>		
<b>CUSTOMER PART NUMBER</b>		
<b>CROSS REF. PART NUMBER</b>		
<b>MEMO</b>		

<b>VENDOR APPROVE</b>			
Issued/Checked/Approved			
Date: Oct. 19, 2024			

<b>CUSTOMER APPROVE</b>	
Date:	

**MAIN FEATURE**

- MHz Thru-Hole Ceramic Resonator, 3 Pins, Lead Length: 13.5mm
- Dimension L9.5\*W4.0\*H5.5mm
- Low Cost And Short Shipment
- Cross Main Competitors Parts CSTLS series
- REACH Complaint The 233 Substances of Very High Concern, as specified by Regulation (EC) No.1907/2006 (REACH).
- RoHS/RoHS III compliant, RoHS Annex III lead Exemption (Exempt per RoHS EU 2015/863)

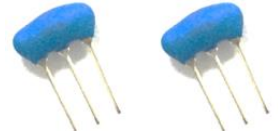

*Image shown is a representation only. Exact specifications should be obtained from the product dimension.*



**APPLICATION**

- Communication Electronics
- Measurement Instrument

**HOW TO ORDER**

- Please follow up part code guide and indicate part code when you order or RFQ.

**RFQ**

[Request For Quotation](#)

**PART CODE GUIDE**

CODE	NAME	KEY SPECIFICATION OPTION
CD	Product Series	MHz Thru-Hole Ceramic Resonator, 3 Pins, Lead Length: 13.5mm Dimension L9.5*W4.0*H5.5mm
2M0	Frequency Range	2M0: 2.00MHz
0000	Internal Control	Letter or Digits (A~Z, a~z or 1~9)
S	Package Type	Packed in Tape and Box
F200	Special Parametric	Letter or Digits (A~Z, a~z or 1~9)
- XX	Suffix	Blank: N/A XX: Internal Control Code, Letter A~Z, a~z or digits (0~9) for Special/Custom Parameters

**DIMENSION** (Unit: mm)

**Thru-Hole Type, 3 Pins**

L9.5\*W4.0\*H5.5mm

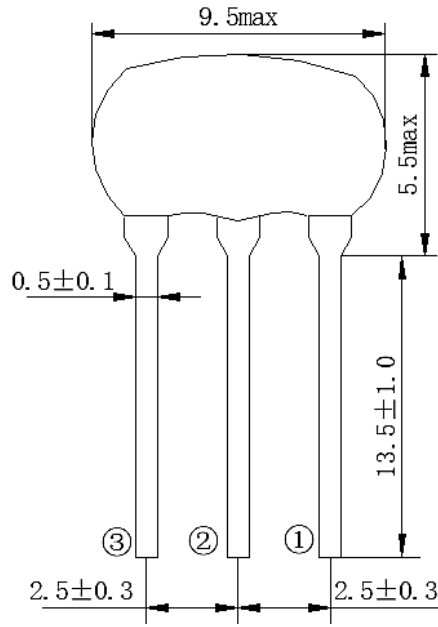

**Marking**

Frequency Range  
+ QC Code/stamp

Connection: ① Input ② Ground ③ Output

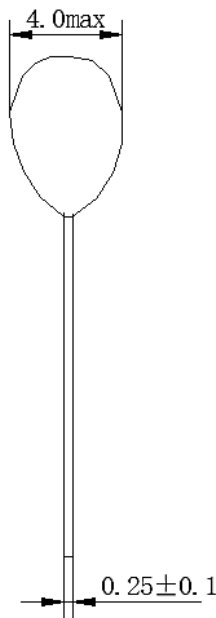

**ELECTRICAL SPECIFICATIONS - Rating**

PARAMETER	CONDITION	SYMBOLS	VALUE	UNITS
Withstanding Voltage Max.	@DC, 1 min.	-	50	V
Insulation Resistance Min.	@10V, 1 min.	R <sub>i</sub>	500	mΩ
Operating Junction e Temp. Range		T <sub>J</sub>	-25 to +85	°C
Storage Temperature Range		T <sub>STG</sub>	-40 to +85	°C
Rating Voltage		UR	6VDC	V
			15V p-p	

**MAIN ELECTRICAL SPECIFICATIONS**

PARAMETER	CONDITION	SYMBOLS	VALUE	UNITS
Center Frequency		f <sub>0</sub>	2.000	MHz
Frequency Accuracy			±0.50	%
Resonant Impedance			80 Max.	Ω
Temperature Coefficient of Oscillation Frequency	@ Oscillation Frequency drift, -25 ~ 85°C		±0.30 Max.	%
Oscillation Frequency Aging Rate * (10 years)	From initial value		±0.30 Max.	%

Note: \* Components shall be left in a chamber of +85 ± 2°C for 1000 hours, then measured after leaving in natural condition for 1 hour.

**PHYSICAL AND ENVIRONMENTAL CHARACTERISTICS**

TEST ITEMS	TEST METHOD AND CONDITIONS	REQUIREMENT
Humidity	Subject the resonator at +40°C±2°C and 90%-95% R.H. for 500h, resonator shall be measured after being placed in natural conditions for 1h.	It shall fulfill the specifications in Table 1.
High Temperature	Subject the resonator to +85°C±2°C for 500h, resonator shall be measured after being placed in natural conditions for 1h.	It shall fulfill the specifications in Table 1.
Low Temperature	Subject the resonator to -55±2°C for 500h, resonator shall be measured after being placed in natural conditions for 1h.	It shall fulfill the specifications in Table 1.
Temperature Cycling	After temperature cycling of blow table was performed 5 times, resonator shall be measured after being placed in natural conditions for 1h.1) Temp.: -40±3°C, Time: 30±3 min ; 2) Temp.: -85±3°C, Time: 30±3 min.	It shall fulfill the specifications in Table 1.
Vibration	Subject the resonator to vibration for 2h. Each in x y and z axis with the amplitude of 1.5mm, The frequency shall be varied uniformly between the limits of 10Hz-55Hz and then resonator shall be measured.	It shall fulfill the specifications in Table 1.
Mechanical Shock	Resonator shall be measured after 3 times random dropping from the height of 1m on concrete floor.	It shall fulfill the specifications in Table 1.
Resistance to Soldering Heat	Lead terminals are immersed up to 2 mm from resonator's body in soldering bath of 260°C±5°C for 10s±1s and then resonator shall be measured after being placed in natural conditions for 1h.	It shall fulfill the specifications in Table 1.
Solderability	Lead terminals are immersed up to 2mm from filter's body in soldering bath of 250±5°C for 3±0.5s.	More than 95% of the terminal surface of the filter shall be covered with fresh solder.

**ENVIRONMENTAL TEST**

TEST ITEMS	TEST METHOD AND CONDITIONS	REQUIREMENT
Terminal Strength	Force of 5N is applied to each lead in axial direction for 10s±1s.	No visible damage
Terminal Pulling	When force of 5N is applied to each lead in axial direction, the lead shall folded up 90°from the axial direction and folded back to the	and it shall fulfill
Terminal Bending	axial direction. The speed of folding shall be each 3s	Table 1.

Table 1

TEST ITEMS	CHARACTERISTICS AFTER TEST	
	VALUE	UNITS
Oscillation Frequency Change $\Delta f_{osc}/f_{osc}$	±0.30 Max.	%
Resonant Impedance $\Delta R_o$	80 Max.	$\Omega$

Note: The limits in the above table are referenced to the initial measurements.

**MEASUREMENT**

- Parts shall be tested under the condition ( Temp.:  $20 \pm 15^\circ\text{C}$ , Humidity  $65 \pm 20\%$  R.H.) unless the standard condition (Temp.:  $25 \pm 3^\circ\text{C}$ , Humidity :  $65 \pm 10\%$  R.H.) is regulated to measure.
- Measuring Circuit

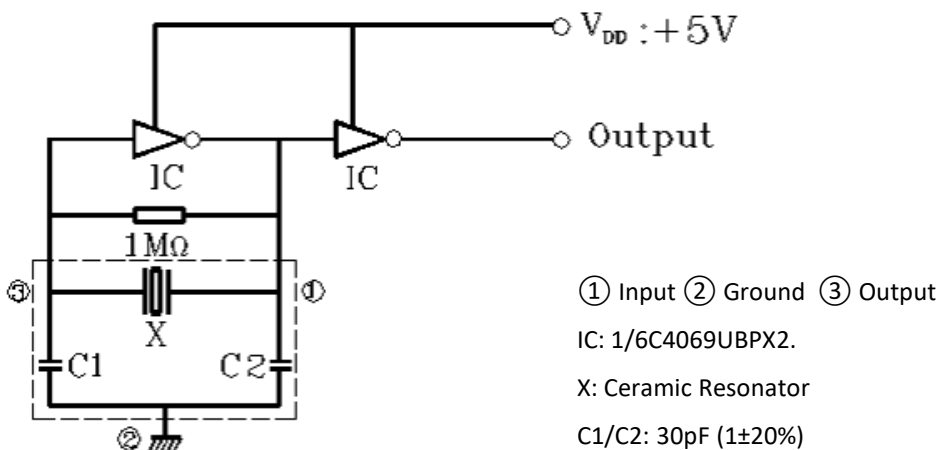

**TAPE** (Unit: mm)

All Devices are packed in accordance with EIA standard RS-481-2 and 2000pcs Packed in Tape and Box

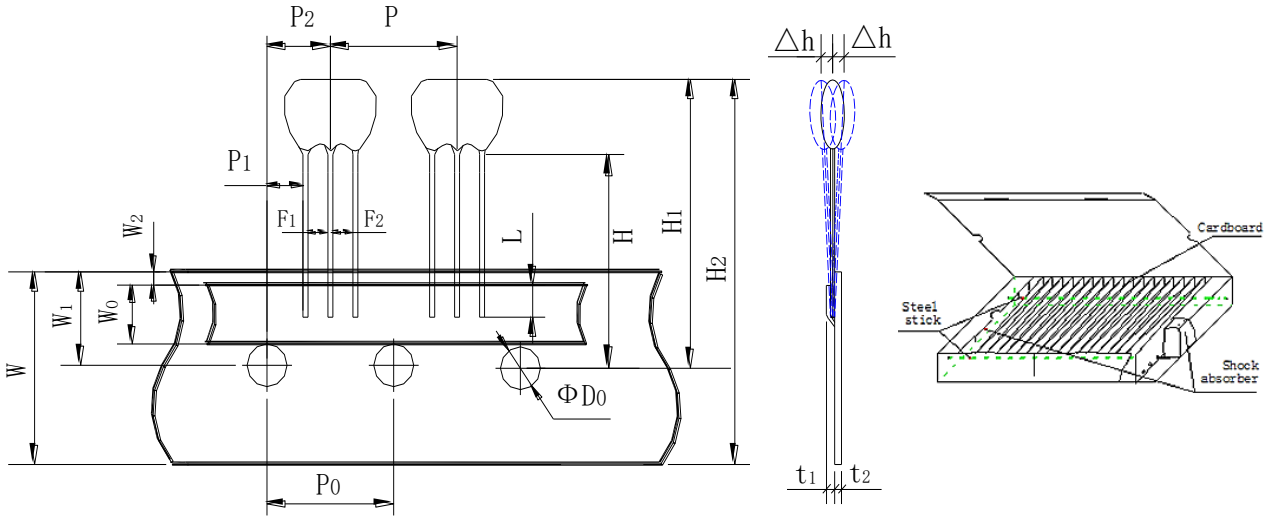

MARK	SIZE(mm)
P	12.7±0.5
Po	12.7±0.2
P1	3.85±0.5
P2	6.35±1.30 (include the slant of product)
F1	2.5±0.3
F2	2.5±0.3
Wo	5.5±0.5
W1	9.0±0.5
W2 max.	1.0
W	18.0±0.5
H	18.0 +0.5 (-1.0)
H1	27.0 max. (Varies with P/N)
H2	36.0 max. (Varies with P/N)
L min.	3.0
ΦDo	4.0±0.2
t1	0.6±0.2
t2 max	1.5
Δh max.	1.0

**PACKAGE – TAPE AND BOX**

- Parts shall be packaged in box with hold down tape upside. Part No., quantity and lot No.
- Leader Tape: More than 300mm leader tape with no products shall be provided at both end of the tape.
- Packing Style: Tape is folded at every 25 pitches in zigzag way, and contained in the box. Steel sticks are inserted the third hole from both edge of the tape. Those are used to keep steady state. Shock absorber or paper board shall be placed between products and box.
- Packing Quantity: 2000pcs are contained in box.

**STIPULATION OF PRODUCTS ALIGNMENT**

- Dropout of parts shall be confined to no more than 3 continuous parts.
- Dropout of parts on a reel shall be less than 0.25% of net quantity.
- All products shall face their marking side toward the hold down tape. (Upward in the figure below in this page)
- Tape Connection:

1) in the case of a carrier tape running out, Connect the back face of tapes together with a adhesive tape. Total thickness of tape 1.05mm max.

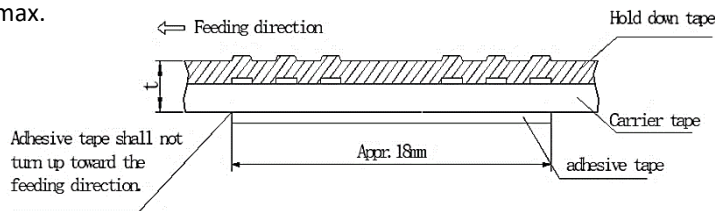

2) In the case of a hold down tape running out, Overlap the hold down tape for connection. Total thickness of tape 1.05mm max.

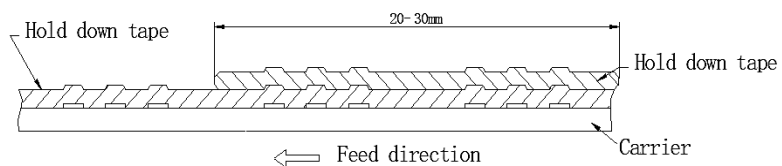

3) In the case of connecting both carrier tape and hold down tape. Connect both carrier tape and hold down tape together with adhesive tape.



## CAUTION

- Don't apply excess mechanical stress to the component and terminals at soldering. Do not use this product with bend.
- Do not clean or wash the component for it is not hermetically sealed.
- Do not use strong acidity flux, more than 0.2wt% chlorine content, in flow soldering.
- Don't be close to fire.
- This specification mentions the quality of the component as a single unit. Please insure the component is thoroughly evaluated in your application circuit
- Expire date (Shelf life) of the products is 12 months after delivery under the conditions of a sealed and an unopened package. Please use the products within 12 months after delivery. If you store the products for a long time (more than 12 months), use carefully because the products may be degraded in the solder-ability or rusty. Please confirm solder-ability and characteristics for the products regularly.
- Exposure components under soldering condition that is exceeding our recommendation will increase the failure dangerous.
- Please contact us before using the product as automobile electronic component.
- Please return one of these specifications after your signature of acceptance.
- When something gets doubtful with this specifications, we shall jointly work to get an agreement.
- For questions on technology, prices and delivery, please contact our sales offices or e-mail:  
[sales@NextGenComponent.com](mailto:sales@NextGenComponent.com) .

## IMPORTANT NOTES AND DISCLAIMER

1. **ROHS COMPLIANCE:** The levels of RoHS restricted materials in this product are below the maximum concentration values (also referred to as the threshold limits) permitted for such substances, or are used in an exempted application, in accordance with EU RoHS Directive (EU) 2015/863 EC (RoHS3). RoHS Test Report for this product can be obtained at Download Center.
2. **REACH COMPLIANCE:** REACH substances of high concern (SVHCs) information is available for this product. Since the European Chemical Agency (ECHA) has published notice of their intent to frequently revise the SVHC listing for the foreseeable future, REACH Test Report for this product can be obtained at Download Center.
3. All Product parametric performance is indicated in the Electrical Characteristics for the listed herein test conditions, unless otherwise noted. Product performance may not be indicated by the Electrical Characteristics if operated under different conditions.
4. NextGen Component, Inc (*NextGen*) reserves the right to make changes to this document and its products and specifications at any time without notice. Customers should obtain and confirm the latest product information and specifications before final design, purchase or use.
5. *NextGen* makes no warranty, representation or guarantee regarding the suitability of its products for any particular purpose, not does *NextGen* assume any liability for application assistance or customer product design.
6. *NextGen* does not warrant or accept any liability with products which are purchased or used for any unintended or unauthorized application. No license is granted by implication or otherwise under any intellectual property rights of NextGen.
7. *NextGen* products are not authorized for use as critical components in life support devices or systems without express written approval by *NextGen*.
8. *NextGen* requires that customers first obtain an RMA (Returned Merchandise Authorization) number prior to returning any products. Returns must be made within 30 days of the date of invoice, be in the original packaging, unused and like-new condition. At the time of quoting or purchasing, a product may say that it is Non-Cancelable/ Non-Returnable (NCNR). These products are not returnable and not refundable.