



<b>SPECIFICATION SHEET NO.</b>	R1102-YR32K76800S001	
<b>ORIGINAL MFG/PART NO</b>	TGS/CCMM 32K768A20-12.5-40-70TLF/SF32WK32768D31T002/MF3215	
<b>NEXTGEN PART CODE</b>	YR32K76800S001	Indicate This Code For <a href="#">RFQ</a> /Order
<b>DATE</b>	Nov. 2, 2024	
<b>REVISION</b>	A4	Updated With Most Recent Data
<b>DESCRIPTION AND MAIN PARAMETRICS</b>	<p>KHz SMD Crystals, Case 3215, 2 Pads, YR series</p> <p>Dimension: L3.2*W1.5*H0.9mm</p> <p>32.76800KHz, Tolerance: ±20ppm, Load Capacitance (CL) 12.5pF</p> <p>ESR 70 Kohm Max., Operating Temp. Range -40°C ~+85°C</p> <p>Reflow Profile Condition 260 °C Max.</p> <p>REACH/RoHS/RoHS III Compliant</p> <p>Packed in Tape/Reel, 3000pcs/Reel</p>	
<b>CUSTOMER</b>		
<b>CUSTOMER PART NUMBER</b>		
<b>CROSS REF. PART NUMBER</b>		
<b>MEMO</b>		

<b>VENDOR APPROVE</b>		
Issued/Checked/Approved		
		
Date: Nov. 2, 2024		

<b>CUSTOMER APPROVE</b>	
Date:	

## MAIN FEATURE

- SMD Package, L3.2\*W1.5\*H0.9mm, 2 Pads
- Industry Standard
- Reflow Profile Condition 260 °C Max.
- Operating Temperature Range: -40~+85°C
- Available CL 6pF/7pF/9pF/12.5pF
- Low ESR 70 Kohm Max.
- Offer Quality Alternatives Parts For Major Brand and more
- Moisture Sensitivity Level (MSL) 1 (Unlimited)
- REACH/RoHS/RoHS III Compliant

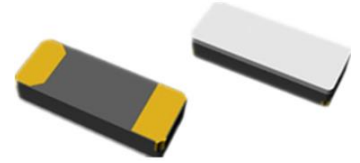

*Image shown is a representation only. Exact specifications should be obtained from the product dimension.*



## MAIN APPLICATION

- Small Communications Devices And More

## ELECTRICAL CHARACTERISTICS

- See Page 6 For Different Part Number.

**HOW TO ORDER**

- Please Follow Up Part Code Guide And Indicate Part Code YR32K76800S001 For RFQ/Order.

**RFQ**  
Request For Quotation

**PART CODE GUIDE**

CODE	NAME	KEY SPECIFICATION OPTION
YR	Product Index	KHz SMD Crystal L3.2*W1.5*H0.9mm, 2 Pads
32K768	Frequency Range	32K768: 32.76800KHz
00S	Internal Control	Special letter A~Z , a~z or digits (1-9)
001	Parameters	Special Parameters Code letter A~Z, a~z or digits (1-9)
XX	Suffix	Blank: N/A XX: Letter A~Z, a~z or digits (0~9) for Special/Custom Parameters

**DIMENSION** (Unit: mm)

Top View

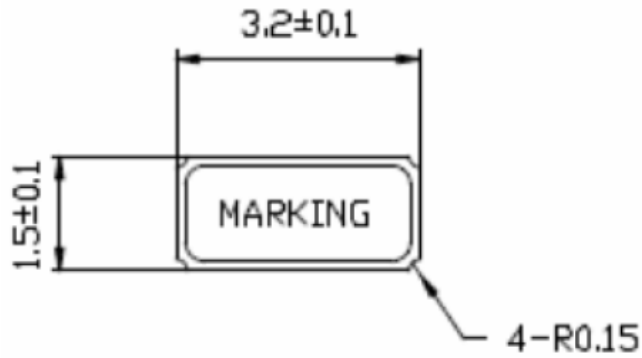

Bottom View

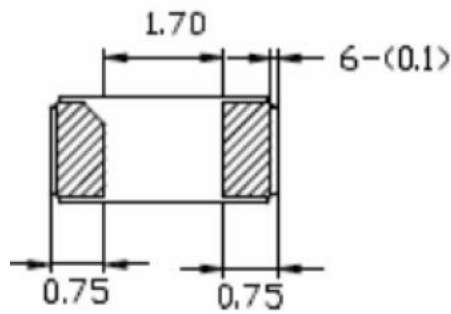

Side View

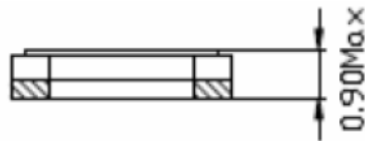

Land Pattern

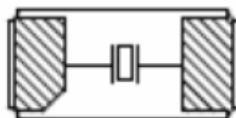
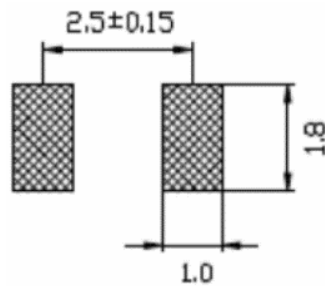

**PRODUCT STRUCTURE**

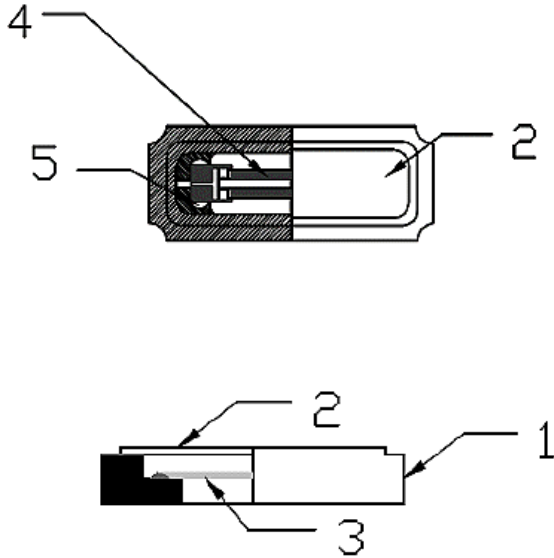

Item No.	Component Name	Material Name
1	Crystal Case	Ceramic (A1203)
2	Crystal Cover/Lid	KV (Fe/Co/Ni)
3	Crystal Chip/Blank	SiO <sub>2</sub>
4	Electrode	Cr, Au (Cr + Au)
5	Adhesive	Resin, Ag

**EQUIVALENT CIRCUIT**

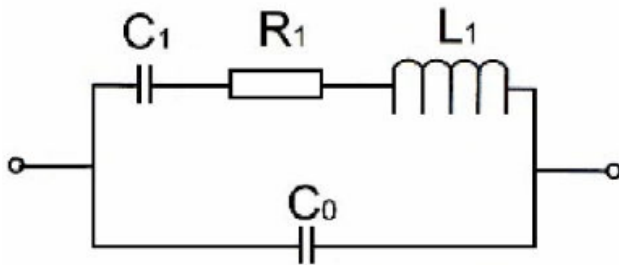

**ELECTRICAL PARAMETERS – FOR DIFFERENT PART CODE- Ta = 25°C**

NEXTGEN PART CODE	ORIGINAL PART NUMBER	FREQUENCY RANGE	FREQUENCY TOLERANCE @ 25°C±3°C	LOAD CAPACITANCE
		KHz	ppm	pF
<a href="#">YR32K76800S001</a>	SF32WK32768D31T002	32.768	±20	12.5
YR32K76800S003	SF32WK32768D71T005	32.768	±20	7
YR32K76800S004	SF32WK32768D61T002	32.768	±20	6
YR32K76800S005	SF32WK32768D91T004	32.768	±20	9

**GENERAL ELECTRICAL PARAMETERS**

PARAMETER	UNITS	VALUE			CONDITION
		MIN.	TYPICAL	MAX.	
Mode of Oscillation		AT Fundamental			
Equivalent Series Resistance (ESR)	KΩ	-	-	70	
Parabolic Coefficient	ppm/°C <sup>2</sup>	-0.04	-	-0.02	
Drive Level (DL)	μW	-	0.1	0.5	
Shunt Capacitance (C0)	pF	-	1.1	2.0	
Dynamic Capacitance (C1)	fF	-	4.1	-	
Turnover Temperature	°C	+20	25	+30	
Insulation Resistance	MΩ	500			@100Vdc, ± 15VDC
Quality Factor (Q)	K	13	-	-	
Operation Temperature	°C	-40	-	+85	
Storage Temperature	°C	-55	-	+125	
Aging	ppm	-3	-	+3	Per Year

**RELIABILITY**

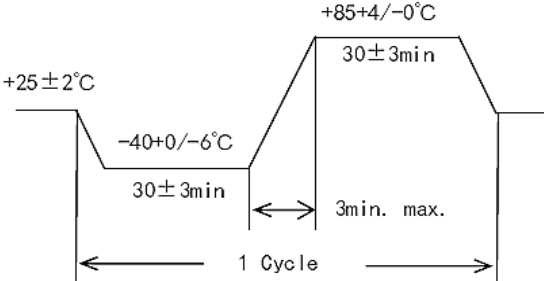
TEST ITEMS	TEST METHOD AND CONDITIONS	TEST STANDARD
High Temperature High Humidity Storage	Temperature: 60°C ± 2 °C Relative Humidity: 90%~95% RH For Time: 500 ± 12 Hours	A, C, D, G
High Temperature Storage	Temperature: 125°C ± 2°C Time: 1000±12 Hours.	B, C, G
Low Temperature Storage	Temperature: -40°C ± 2°C Time: 500 ± 12 Hours.	A, C, G
Temperature Cycle	The crystal unit shall be subjected to 100 successive change of temperature cycles.   <p>The diagram illustrates a temperature cycle. It starts at a high temperature of +25 ± 2°C, drops to a low temperature of -40 ± 6°C, and dwells there for 30 ± 3 minutes. It then ramps up to a high temperature of +85 ± 4/-0°C, dwells there for 30 ± 3 minutes, and finally ramps down. The ramping times are limited to a maximum of 3 minutes. The entire sequence is labeled as '1 Cycle'.</p>	A, C, G
Solderability	The solder pot temperature is 260±5°C , dwell time 2±0.6sec	F
Drop Test	Height: 180 cm; Dropped Cycle: 3 cycles; Drop it on to a concrete board for 6 Directions (X,Y,Z), that should be 1 cycle	B, C
Vibration	Frequency Range: 10Hz ~ 55Hz Amplitude: 1.5mm±15%; Sweep time: 2~3 Minutes, 2 Hours in each direction, total 6 Hours	A, C
Leakage Test	Helium Bombing 5.0 ~5.5 Kg/cm <sup>2</sup> ; for 2 hours	E

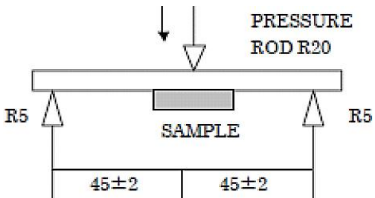
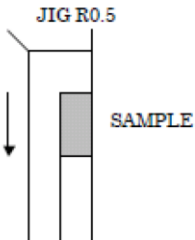
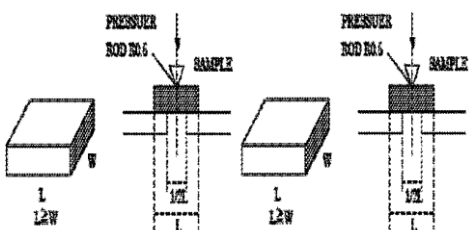
TEST ITEMS	TEST METHOD AND CONDITIONS	TEST STANDARD
Terminal Strength	<p>Shall be pressurized at a speed of approx. 0.5mm/sec. in the direction indicated by the arrow unit the bending width reaches 3mm and held for 5 sec.</p> 	B, C
Sticking Tendency	<p>A R0.5 Jig shall be used to apply a 10N dead load in the direction indicated by the arrow to the element and retain it for 10 sec.</p> 	B, C
Element Assembly Strength	<p>A R0.5 Jig shall be used to apply a 10N dead load in the direction indicated by the arrow to the element and retain it for 10 sec.</p> 	B, C



**TEST STANDARD**

TEST STANDARD SYMBOL	SPECIFICATION	VALUE
A	Frequency Change permitted	$\Delta F \leq 10 \text{ppm}$
B	Frequency Change permitted	$\Delta F \leq 20 \text{ppm}$
C	Equivalent Series Resistance Change Permitted	$\Delta C I \leq 5 \text{K}\Omega$ or 20%
D	Insulation Resistance	$> 500 \text{ M}\Omega$
E	Leak Rate Less than	$< 1 * 1 \text{E-}9 \text{ Pa} \cdot \text{m}^3/\text{sec.}$
F	A new uniform coating of solder shall cover a Min 95% of the crystal surface	
G	Then $25 \pm 2^\circ\text{C}$ over 2 hours before Testing	

**SUGGESTED REFLOW PROFILE** (For Reference No. JEDEC J-STD-020D)

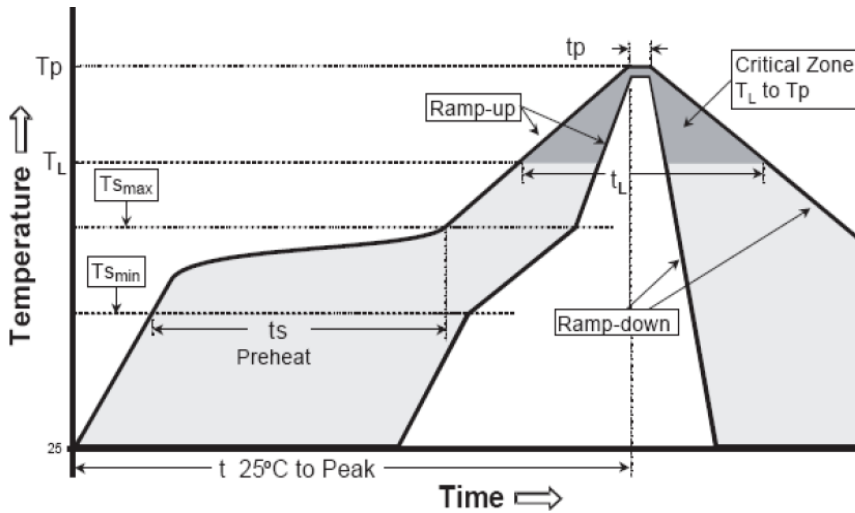

PROFILE FEATURE		PB-FREE ASSEMBLY
Average Ramp-up Rate (Ts Max to Tp)		3°C/second Max
Preheat	Temperature Min (Ts Min.)	150°C
	Temperature Max (Ts Max.)	200°C
	Time (ts Min. to ts Max.)	60 ~ 120 seconds
Time maintained above	Temperature (Tl)	217°C
	Time (tl)	60 ~ 150 seconds
Peak/Classification Temperature (Tp)		260 +/-5°C
Time within 5°C of actual Peak Temperature (tp)		20 ~ 40 seconds
Ramp-down rate		6 °C /Second Max.
Time 25 °C to Peak Temperature		8 minutes Max.
Suggest reflow times		3 Times Max.

**REEL AND TAPE DIMENSION** (Unit: mm)

All Devices are packed in accordance with EIA standard RS-481-2 and specifications, 3000pcs/Reel

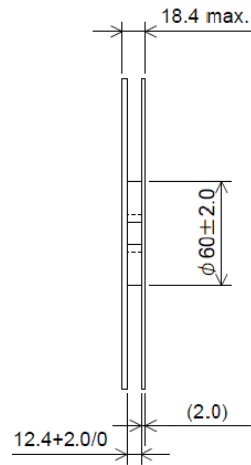
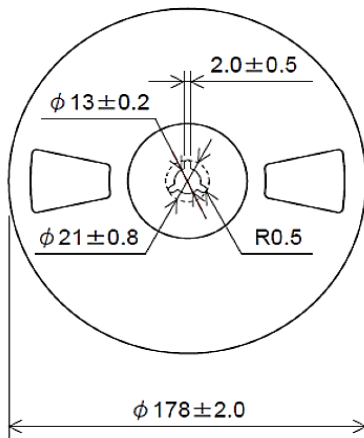
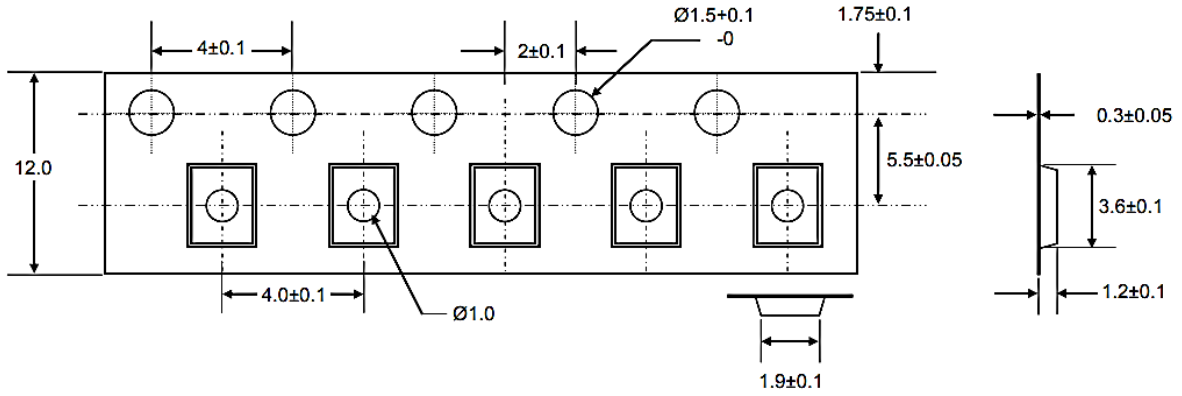

## **NOTES BEFORE USE**

### **Ultrasonic Cleaning**

General cleaning solutions or ultrasonic cleaning method may be used to clean our products. However, under certain circumstances, ultrasonic cleaning machine could generate resonance at the oscillation frequency of our products and thus deteriorate the electrical characteristics in device and even damage the overall structure of device. Therefore, verification test is recommended before cleaning.

### **Ultrasonic Welding**

Avoid mounting and processing by Ultrasonic welding this method has a possibility of an excessive vibration spreading inside the crystal products and become the cause of characteristic deterioration and not oscillating.

### **Storage Temperature Description**

Storage Temperature is only for the product itself, the temperature for the packing material is 5~40°C

Recommended Conditions for Manual Welding Max. Temperature: 350±10°C, Time: 3 sec Max., Re-solder time: twice Max.

## **IMPORTANT NOTES AND DISCLAIMER**

1. **ROHS COMPLIANCE:** The levels of RoHS restricted materials in this product are below the maximum concentration values (also referred to as the threshold limits) permitted for such substances, or are used in an exempted application, in accordance with EU RoHS Directive (EU) 2015/863 EC (RoHS3). RoHS Test Report for this product can be obtained at Download Center.
2. **REACH COMPLIANCE:** REACH substances of high concern (SVHCs) information is available for this product. Since the European Chemical Agency (ECHA) has published notice of their intent to frequently revise the SVHC listing for the foreseeable future, REACH Test Report for this product can be obtained at Download Center.
3. All Product parametric performance is indicated in the Electrical Characteristics for the listed herein test conditions, unless otherwise noted. Product performance may not be indicated by the Electrical Characteristics if operated under different conditions.
4. NextGen Component, Inc (*NextGen*) reserves the right to make changes to this document and its products and specifications at any time without notice. Customers should obtain and confirm the latest product information and specifications before final design, purchase or use.
5. *NextGen* makes no warranty, representation or guarantee regarding the suitability of its products for any particular purpose, not does *NextGen* assume any liability for application assistance or customer product design.
6. *NextGen* does not warrant or accept any liability with products which are purchased or used for any unintended or unauthorized application. No license is granted by implication or otherwise under any intellectual property rights of NextGen.
7. *NextGen* products are not authorized for use as critical components in life support devices or systems without express written approval by *NextGen*.
8. *NextGen* requires that customers first obtain an RMA (Returned Merchandise Authorization) number prior to returning any products. Returns must be made within 30 days of the date of invoice, be in the original packaging, unused and like-new condition. At the time of quoting or purchasing, a product may say that it is Non-Cancelable/ Non-Returnable (NCNR). These products are not returnable and not refundable.