



SPECIFICATION SHEET NO.	R1108- JA108M025HGHR	
ORIGINAL MFG/PART NO	Aillen Capacitors/CBE108M1EHJAG16RR	
NEXTGEN PART CODE	JA108M025HGHR	Indicate This Code For RFQ /Order
DATE	Nov. 8, 2024	
REVISION	A6	Updated With Most Recent Data
DESCRIPTION AND MAIN PARAMETRICS	<p>Dip Aluminum Electrolytic Capacitors, Radial Type, JA series, 2 Pins</p> <p>Capacitance: 1000μF, Tolerance \pm20%, Voltage 25V,</p> <p>Case size: \varnothing10.0*L16.0mm, Ripple Current: 740mA, Max.</p> <p>Load Life: 2,000 Hours, Operating Temp. Range -55°C ~+105°C</p> <p>Package in Bulk</p> <p>REACH/RoHS/RoHS III Compliant & Halogen Free</p>	
CUSTOMER		
CUSTOMER PART NUMBER		
CROSS REF. PART NUMBER		
MEMO		

VENDOR APPROVE			
Issued/Checked/Approved			
Date: Nov. 8, 2024			

CUSTOMER APPROVE	
DATE:	

MAIN FEATURE

- Through Hole Aluminum Electrolytic Capacitors, Radial Type
- Load Life 2000 hours
- High Working Voltage and High Ripple Current
- Package in Bulk, Box and Tape Option
- Operating Temperature Range: -55~+105°C
- Available For High Density Surface Mounting
- Rated Voltage Range from 6.3V to 100V
- Offer Quality Alternatives Parts For Major Brand KEMET/CHEMI-CON/NICHICON /RUBYCON and more
- Moisture Sensitivity Level (MSL) 1 (Unlimited)
- REACH/RoHS/RoHS III Compliant & Halogen Free



*Image shown is a representation only.
Exact specifications should be
obtained from the product dimension.*



MAIN APPLICATION

- For High Frequency Circuits Such As LED Circuit, Switching Power Supply
- Main Board (Voltage Regulation Module) Circuit, Frequency Converter Circuit, Etc.

ELECTRICAL CHARACTERISTICS

- See Page 6 ~ Page 15 for Different Part Code
- All Products Parameters are Subject To NextGen Components' Final Confirmation.

HOW TO ORDER

- Please Follow Up Part Code Guide And Indicate Part Code [JA108M025HGHR](#) For [RFQ](#)/Order.

PART CODE GUIDE

RFQ

[Request For Quotation](#)

CODE	NAME	KEY SPECIFICATION OPTION
JA	Product Index	Dip Capacitors Aluminum Electrolytic, Radial Type, Original Series Number CDJA
108	Rated Capacitance	225: 2.2μF; 335: 3.3μF; 475: 4.7μF; 106: 10μF; 226: 22μF; 276: 22μF 336: 33μF; 476: 47μF; 107: 100μF; 227: 220μF; 337: 330μF; 477: 470μF; 108: 1000μF; 128: 1200μF; 228: 2200μF; 338: 3300μF; 478: 4700μF; 688: 6800μF; 109: 10000μF 229: 22000μF
M	Capacitance Tolerance	M: ±20%; V: -10% ~ +20%
025	Rated Voltage	6V3: 6.3V; 010: 10V; 016:16V; 025: 25V; 035: 35V; 050: 50V; 063: 63V; 100: 100V
H	Environmental Requirements	R: RoHS/RoHS III Complaint Remark: Product Set PVC Sleeve H: RoHS/RoHS III Complaint and Halogen Free, Remark: Product Set PET Sleeve
G	Aluminum Case Diameter	C: Ø4.0mm; D: Ø5.0mm; E: Ø6.3mm; F: Ø8.0mm; G: Ø10.0mm; J: Ø13.0mm; K: Ø16.0mm; L: Ø18.0mm;
H	Aluminum Case Height	When the code is number, it represent the actual height. E.g. 7: L7.0mm; 8: L8.0mm; 9: L9.0mm; A: L11mm; B: L11.5mm; C: L12mm; D: L12.5mm; E: L20mm; F: L21.5mm; H: 16mm; I: 24.5mm; J: L25mm; K: L30mm; L: L31.5mm; M: L35mm; N: L35.5mm; O: L40mm;
RR	Lead Pitch/Package (see Page 23 ~ Page 30)	The length of the product's cut feet starts from A=3.0mm. Every time it increases by 0.5mm, the English word is pushed forward one place, as shown following table: RR: Bulk; R2: F8, Lead Pitch=2.5mm Bulk; T2: Lead Pitch=2.0mm Tape TB: Lead Pitch=2.5mm Tape; T3: Lead Pitch=3.5mm Tape; T5 & TF: Lead Pitch=5.0mm Tape; T7: Lead Pitch=7.5mm Tape; CA: Cutting Lead long=3.0mm; CB: Cutting Lead long=3.5mm; CC: Cutting Lead long=4.0mm; KD: Forming "K" feet long=4.5mm
XX	Suffix	Blank: N/A XX: Internal Control Code, Letter A~Z, a~z or digits (0~9) for Special/Custom Parameters

DIMENSIONS (Unit: mm)

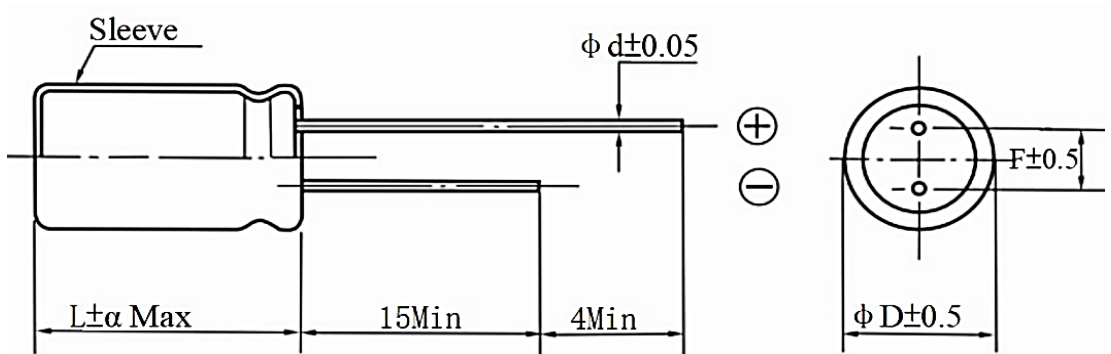

SYMBOL	DIMENSION								
	5.0	6.3	8.0	8.0	10	12.5/13	16	18	22
D	5.0	6.3	8.0	8.0	10	12.5/13	16	18	22
F	2.0	2.5	2.5/3.5	3.5	5.0	5.0	7.5	7.5	10
d	(L ≤ 7): 0.45; (L > 7): 0.5			0.6	0.6	0.6/0.7	0.8	0.8	1.0
L	7/8/9/11/11.5/12/12.5/16			20/21.5/24.5/25/30/31.5/35/35.5/40					
α	1.5			2.0					

MARKING GUIDE

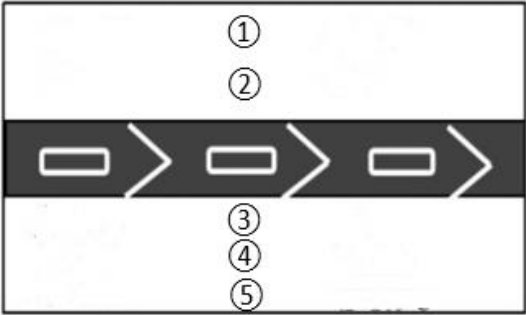
NAME	SYMBOL	CONTENT
Nominal Capacitance	①	1000μF
Rated Voltage	②	25V
Polarity		
Original Manufacturer	③	Aillen
QC Code and Series Code	④	CDJA
Temperature Range	⑤	-55~+105°C
Casing Type		Sleeve and printing color: White Printing on black Sleeve
Marking		

CONSTRUCTION

Single ended type to be produced to fix the terminals to anode and cathode foil, and wind together with paper, and then wound element to be impregnated with electrolyte will be enclosed in an aluminum case. Finally sealed up tightly with end seal rubber, then finished by putting on the vinyl sleeve.

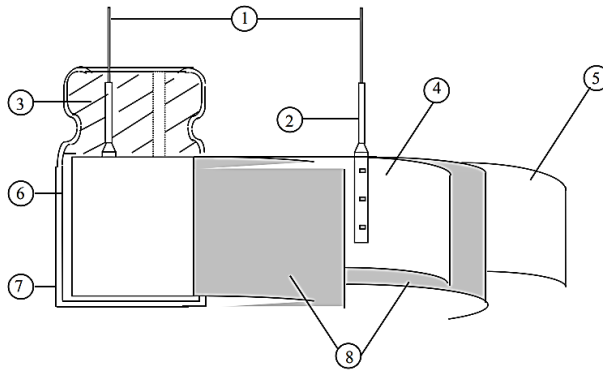

NO.	COMPONENT	MATERIAL
1	Lead Line	Tinned CP Wire (Pb Free)
2	Terminal	Aluminum Wire
3	Sealing Material	Rubber
4	Al-Foil (+)	Formed Aluminum Foil
5	Al-Foil (-)	Etched Aluminum Foil Or Formed Aluminum Foil
6	Case	Aluminum Case
7	Sleeve	PET
8	Separator	Electrolyte Paper

GENERAL ELECTRICAL CHARACTERISTICS – FOR DIFFERENT PART CODE

PARAMETER	UNITS	VALUE
Operating Junction Temperature Range	°C	-55 ~ +105
Storage Temperature Range	°C	-55 ~ +150

ELECTRICAL CHARACTERISTICS - Ta = 25°C, FOR DIFFERENT PART CODE

NEXTGEN PART CODE	ORIGINAL PART NUMBER	RATE VOL.	CAPACITOR VALUE	MAX. TANδ @+20°C 120HZ	MAX. RIPPLE CURRENT @ 105°C 120HZ	CASE SIZE ØD X L
		V	µF	%	mA	mm
JA107M010HDARR	CBE107M1AHJAD11RR	10	100	20	105	5x11
JA227M010HDARR	CBE227M1AHJAD11RR	10	220	20	150	5x11
JA337M010HEARR	CBE337M1AHJAE11RR	10	330	20	200	6.3x11
JA477M010HEARR	CBE477M1AHJAE11RR	10	470	20	250	6.3x11
JA477M010HFCRR	CBE477M1AHJAF12RR	10	470	20	290	8x12
JA108M010HGDRR	CBE108M1AHJAG1BRR	10	1000	20	460	10x12.5
JA228M010HGERR	CBE228M1AHJAG20RR	10	2200	20	760	10x20
JA338M010HJERR	CBE338M1AHJAJ20RR	10	3300	20	1100	13x20
JA478M010HJJRR	CBE478M1AHJAJ25RR	10	4700	20	1260	13x25
JA688M010HKJRR	CBE688M1AHJAK25RR	10	6800	20	1690	16x25
JA109M010HKKRR	CBE109M1AHJAK30RR	10	10000	20	2220	16x30
JA229M010HLORR	CBE229M1AHJAL40RR	10	22000	20	3230	18x40

ELECTRICAL CHARACTERISTICS - Ta = 25°C, FOR DIFFERENT PART CODE

NEXTGEN PART CODE	ORIGINAL PART NUMBER	RATE VOL.	CAPACITOR VALUE	MAX. TANδ @+20°C 120HZ	MAX. RIPPLE CURRENT @ 105°C 120HZ	CASE SIZE ØD X L
		V	µF	%	mA	mm
JA476M016HC7RR	CBE476M1CHJACO7RR	16	47	16	45	4x7
JA107M016HDARR	CBE107MICHJAD11RR	16	100	16	119	5x11
JA227M016HEARR	CBE227M1CHJAE11RR	16	220	16	180	6.3x11
JA337M016HFCRR	CBE337M1CHJAF12RR	16	330	16	260	8x12
JA477M016HFCRR	CBE477M1CHJAF12RR	16	470	16	310	8x12
JA108M016HGHR	CBE108M1CHJAG16RR	16	1000	16	560	10x16
JA228M016HJERR	CBE228M1CHJAJ20RR	16	2200	16	920	13x20
JA338M016HJJRR	CBE338M1CHJAJ25RR	16	3300	16	1170	13x25
JA478M016HKJRR	CBE478M1CHJAK25RR	16	4700	16	1480	16x25
JA688M016HKKRR	CBE688M1CHJAK30RR	16	6800	16	1930	16x30
JA688M016HKLRR	CBE688M1CHJAK3ARR	16	6800	16	1930	16x31.5
JA109M016HLKRR	CBE109M1CHJAL30RR	16	10000	16	2330	18x30
JA109M016HKKRR	CBE109M1CHJAK30RR	16	10000	16	2100	16x30
JA109M016HKLRR	CBE109M1CHJAK3ARR	16	10000	16	2100	16x31.5

ELECTRICAL CHARACTERISTICS - Ta = 25°C, FOR DIFFERENT PART CODE

NEXTGEN PART CODE	ORIGINAL PART NUMBER	RATE VOL.	CAPACITOR VALUE	MAX. TANδ @+20°C 120HZ	MAX. RIPPLE CURRENT @ 105°C 120HZ	CASE SIZE ØD X L
		V	µF	%	mA	mm
JA106M025HDARR	CBE106M1EHJAD11RR	25	10	14	38	5x11
JA476M025HDARR	CBE476M1EHJAD11RR	25	47	14	97	5x11
JA107M025HEARR	CBE107M1EHJAE11RR	25	100	14	151	6.3x11
JA227M025HFCRR	CBE227M1EHJAF12RR	25	220	14	236	8x12
JA337M025HFCRR	CBE337M1EHJAF12RR	25	330	14	340	8x12
JA337M025HGDRR	CBE337M1EHJAG1BRR	25	330	14	352	10x12.5
JA477M025HGDRR	CBE477M1EHJAG1BRR	25	470	14	380	10x12.5
JA108M025HGHR	CBE108M1EHJAG16RR	25	1000	14	740	10x16
JA108M025HGERR	CBE108M1EHJAG20RR	25	1000	14	745	10x20
JA228M025HJJRR	CEB228M1EHJAJ25RR	25	2200	14	1110	13x25
JA338M025HKJRR	CBE338M1EHJAK25RR	25	3300	14	1400	16x25
JA478M025HKJRR	CBE478M1EHJAK25RR	25	4700	14	1570	16x25
JA478M025HKLRR	CBE478M1EHJAK3ARR	25	4700	14	1750	16x31.5
JA688M025HLMRR	CBE688M1EHJAL35RR	25	6800	14	2160	18x35

ELECTRICAL CHARACTERISTICS - Ta = 25°C, FOR DIFFERENT PART CODE

NEXTGEN PART CODE	ORIGINAL PART NUMBER	RATE VOL.	CAPACITOR VALUE	MAX. TANδ @+20°C 120HZ	MAX. RIPPLE CURRENT @ 105°C 120HZ	CASE SIZE Ø D X L
		V	µF	%	mA	mm
JA225M050HDARR	CBE225M1HHJAD11RR	50	2.2	10	20	5x11
JA335M050HDARR	CBE335M1HHJAD11RR	50	3.3	10	30	5x11
JA475M050HDARR	CBE475M1HHJAD11RR	50	4.7	10	35	5x11
JA106M050HDARR	CBE106M1HHJAD11RR	50	10	10	51	5x11
JA226M050HDARR	CBE226M1HHJAD11RR	50	22	10	79	5x11
JA336M050HDARR	CBE336M1HHJAD11RR	50	33	10	90	5x11
JA476M050HEARR	CBE476M1HHJAE11RR	50	47	10	117	6.3x11
JA107M050HFBRR	CBE107M1HHJAF1ARR	50	100	10	218	8x11.5
JA107M050HFCRR	CBE107M1HHJAF12RR	50	100	10	218	8x12
JA227M050HGHR	CBE227M1HHJAG16RR	50	220	10	335	10x16
JA337M050HGHR	CBE337M1HHJAG16RR	50	330	10	410	10x16
JA337M050HGERR	CBE337M1HHJAG20RR	50	330	10	460	10x20
JA477M050HJERR	CBE477M1HHJAJ20RR	50	470	10	590	13x20
JA108M050HJJRR	CBE108M1HHJAJ25RR	50	1000	10	1060	13x25
JA108M050HKJRR	CBE108M1HHJAK25RR	50	1000	10	1080	16x25
JA228M050HKMRR	CBE228M1HHJAK35RR	50	2200	10	1470	16x35
JA338M050HLMRR	CBE338M1HHJAL35RR	50	3300	10	1650	18x35
JA688M050HKLRR	CBE688M1HHJAK1ARR	50	6800	10	1780	16x31.5

ELECTRICAL CHARACTERISTICS - Ta = 25°C, FOR DIFFERENT PART CODE

NEXTGEN PART CODE	ORIGINAL PART NUMBER	RATE VOL.	CAPACITOR VALUE	MAX. TANδ @+20°C 120HZ	MAX. RIPPLE CURRENT @ 105°C 120HZ	CASE SIZE ØD X L
		V	µF	%	mA	mm
JA475M063HDARR	CBE475M1JHJAD11RR	63	4.7	9	36	5x11
JA106M063HDARR	CBE106M1JHJAD11RR	63	10	9	54	5x11
JA226M063HEARR	CBE226M1JHJAE11RR	63	22	9	86	6.3x11
JA336M063HEARR	CBE336M1JHJAE11RR	63	33	9	100	6.3x11
JA476M063HEARR	CBE476M1JHJAE11RR	63	47	9	129	6.3x11
JA107M063HGDRR	CBE107M1JHJAG1BRR	63	100	9	235	10x12.5
JA107M063HGHRR	CBE107M1JHJAG16RR	63	100	9	290	10x16
JA227M063HGHRR	CBE227M1JHJAG16RR	63	220	9	362	10x16
JA227M063HGERR	CBE227M1JHJAG20RR	63	220	9	400	10x20
JA337M063HGERR	CBE337M1JHJAG20RR	63	330	9	490	10x20
JA337M063HJERR	CBE337M1JHJAJ20RR	63	330	9	520	13x20
JA477M063HJERR	CBE477M1JHJAJ20RR	63	470	9	665	13x20
JA477M063HJJRR	CBE477M1JHJAJ25RR	63	470	9	720	13x25
JA108M063HKJRR	CBE108M1JHJAK25RR	63	1000	9	1190	16x25
JA128M063HKKRR	CBE128M1JHJAK30RR	63	1200	9	1250	16x30
JA228M063HLMRR	CBE228M1JHJAL35RR	63	2200	9	1650	18x35

ELECTRICAL CHARACTERISTICS - Ta = 25°C, FOR DIFFERENT PART CODE

NEXTGEN PART CODE	ORIGINAL PART NUMBER	RATE	CAPACITOR	MAX. TANδ	MAX.	CASE
		VOL.	VALUE	@+20°C	RIPPLE CURRENT	SIZE
		V	μF	%	mA	ØD X L
JA225M100HDARR	CBE225M2AHJAD11RR	100	2.2	8	26	5x11
JA335M100HDARR	CBE335M2AHJAD11RR	100	3.3	8	31	5x11
JA475M100HEARR	CBE475M2AHJAE11RR	100	4.7	8	40	6.3x11
JA106M100HEARR	CBE106M2AHJAE11RR	100	10	8	54	6.3x11
JA226M100HEARR	CBE226M2AHJAE11RR	100	22	8	93	6.3x11
JA226M100HFCRR	CBE226M2AHJAF12RR	100	22	8	111	8x12
JA336M100HFCRR	CBE336M2AHJAF12RR	100	33	8	144	8x12
JA336M100HGDRR	CBE336M2AHJAG1BRR	100	33	8	183	10x12.5
JA476M100HGDRR	CBE476M2AHJAG1BRR	100	47	8	204	10x12.5
JA107M100HGERR	CBE107M2AHJAG20RR	100	100	8	285	10x20
JA227M100HJJRR	CBE227M2AHJAJ25RR	100	220	8	440	13x25
JA337M100HKJRR	CBE337M2AHJAK25RR	100	330	8	478	16x25
JA477M100HKJRR	CBE477M2AHJAK25RR	100	470	8	680	16x25
JA477M100HKKRR	CBE477M2AHJAK30RR	100	470	8	688	16x30
JA108M100HLNRR	CBE108M2AHJAL3ERR	100	1000	8	960	18x35.5

Remark:

1. Specification are subject to change without notice should a safety or technical concern arise regarding the product ,please be sure to contact our sales offices
2. The sizes in the above table are all general specifications. If you need other specifications, please contact us.

MULTIPLIER FOR RIPPLE CURRENT

Frequency Coefficient

Frequency (Hz) Coefficient	60 (50)	120	500	1K	≥10K
Cap. (μF)					
≤100	0.70	1.00	1.30	1.40	1.50
100 < C ≤ 1000	0.75	1.00	1.20	1.30	1.35
1000 < C	0.80	1.00	1.10	1.12	1.15

Temperature Coefficient

Ambient Temperature (°C)	105	85	≤70
Coefficient	1.0	1.5	2.0

Cutting The Feet Long

Cutting Length Code	Cutting Length (mm)
CA	3.0 ± 0.5
CB	3.5 ± 0.5
CC	4.0 ± 0.5
CD	4.5 ± 0.5
CE	5.0 ± 0.5
CG	6.0 ± 0.5
And so on.....	

Note:

- The length of the product’s cut feet starts from A=3.0mm. Every time it increases by 0.5mm.
- The English word is pushed forward one place, as shown in the table.

CHARACTERISTICS

Standard atmospheric conditions

The standard range of atmospheric conditions for making measurements/test as follows:

Ambient temperature: 15°C to 35°C

Relative humidity: 45% to 85%

Air Pressure: 86kPa to 106kPa

If there is any doubt about the results, measurement shall be made within the following conditions:

Ambient temperature: 20°C \pm 2°C

Relative humidity: 60% to 70%

Air Pressure: 86kPa to 106kPa

Operating temperature range

The ambient temperature range at which the capacitor can be operated continuously at rated voltage is (6.3~100WV), -55~+105°C. As to the detailed information, please refer to following table.

ITEM	CHARACTERISTICS																		
Nominal Capacitance (Tolerance)	<p><Condition></p> <p>Measuring Frequency: 120Hz±12Hz</p> <p>Measuring Voltage: Not more than 0.5V</p> <p>Measuring Temperature : 20±2°C</p> <p><Criteria></p> <p>Shall be within the specified capacitance tolerance</p>																		
Leakage Current	<p><Condition></p> <p>After DC Voltage is applied to capacitors through the series protective resistor (1kΩ±10Ω) so that terminal voltage may reach the reacted use voltage.</p> <p>The leakage current when measured in 2 minutes shall not exceed the values of the following equation.</p> <p><Criteria></p> <p>$I \leq 0.01CV$ or 3 (μA) whichever is greater.</p> <p>I: Leakage current (μA)</p> <p>C: Capacitance (μF)</p> <p>V: Rated DC working voltage (V)</p>																		
tanδ	<p><Condition></p> <p>See Nominal capacitance, for measuring frequency , voltage and temperature</p> <p><Criteria></p> <table border="1" data-bbox="384 1384 1298 1508"> <tr> <td>Working voltage (v)</td> <td>10</td> <td>16</td> <td>25</td> <td>35</td> <td>50</td> <td>63</td> <td>100</td> </tr> <tr> <td>tan δ (Max.)</td> <td>0.20</td> <td>0.16</td> <td>0.14</td> <td>0.12</td> <td>0.10</td> <td>0.09</td> <td>0.08</td> </tr> </table> <p>For capacitance value >1000uF, add 0.02per another 1000uF</p>	Working voltage (v)	10	16	25	35	50	63	100	tan δ (Max.)	0.20	0.16	0.14	0.12	0.10	0.09	0.08		
Working voltage (v)	10	16	25	35	50	63	100												
tan δ (Max.)	0.20	0.16	0.14	0.12	0.10	0.09	0.08												
Rated Voltage (WV) Surge Voltage (SV)	<table border="1" data-bbox="384 1665 1298 1819"> <tr> <td>WV (V.DC)</td> <td>6.3</td> <td>10</td> <td>16</td> <td>25</td> <td>35</td> <td>50</td> <td>63</td> <td>100</td> </tr> <tr> <td>SV (V.DC)</td> <td>8.0</td> <td>13</td> <td>20</td> <td>32</td> <td>44</td> <td>63</td> <td>79</td> <td>125</td> </tr> </table>	WV (V.DC)	6.3	10	16	25	35	50	63	100	SV (V.DC)	8.0	13	20	32	44	63	79	125
WV (V.DC)	6.3	10	16	25	35	50	63	100											
SV (V.DC)	8.0	13	20	32	44	63	79	125											

ITEM	CHARACTERISTICS																																																																		
Temperature Characteristics IEC-60384-4 4.12	<p><Condition></p> <table border="1" data-bbox="402 375 1310 679"> <thead> <tr> <th>Step</th> <th>Testing temperature(°C)</th> <th>Time</th> </tr> </thead> <tbody> <tr> <td>1</td> <td>20±2</td> <td>Time to reach thermal equilibrium</td> </tr> <tr> <td>2</td> <td>-55(-25)±3</td> <td>Time to reach thermal equilibrium</td> </tr> <tr> <td>3</td> <td>20±2</td> <td>Time to reach thermal equilibrium</td> </tr> <tr> <td>4</td> <td>105±2</td> <td>Time to reach thermal equilibrium</td> </tr> <tr> <td>5</td> <td>20±2</td> <td>Time to reach thermal equilibrium</td> </tr> </tbody> </table> <p><Criteria></p> <ul style="list-style-type: none"> At +105°C: capacitance measured shall be within ±20% of its original value at +20°C: tan δ shall be within the limit of tanδ, The leakage current value at +105°C shall not more than 8 times the specified value. In step 5, tan δ shall be within the limit of tanδ, The leakage current shall not more than the specified value. At -55 °C (-25 °C) : Impedance (Z) ratio shall not exceed the following value. <table border="1" data-bbox="402 1036 1310 1309"> <thead> <tr> <th colspan="2">Rated Voltage (V)</th> <th>6.3</th> <th>10</th> <th>16</th> <th>25</th> <th>35</th> <th>50</th> <th>63</th> <th>100</th> </tr> </thead> <tbody> <tr> <td rowspan="2">Z-25°C/ Z +20°C</td> <td>φD<16</td> <td>4</td> <td>3</td> <td>3</td> <td>2</td> <td>2</td> <td>2</td> <td>2</td> <td>2</td> </tr> <tr> <td>φD≥16</td> <td>5</td> <td>4</td> <td>3</td> <td>2</td> <td>2</td> <td>2</td> <td>2</td> <td>3</td> </tr> <tr> <td rowspan="2">Z(-40°C/-55 °C) Z +20°C</td> <td>φD<16</td> <td>8</td> <td>6</td> <td>4</td> <td>4</td> <td>4</td> <td>3</td> <td>3</td> <td>3</td> </tr> <tr> <td>φD≥16</td> <td>12</td> <td>8</td> <td>6</td> <td>4</td> <td>3</td> <td>3</td> <td>3</td> <td>6</td> </tr> </tbody> </table> <p>Capacitance, tan δ, and impedance shall be measured at 120Hz.</p>	Step	Testing temperature(°C)	Time	1	20±2	Time to reach thermal equilibrium	2	-55(-25)±3	Time to reach thermal equilibrium	3	20±2	Time to reach thermal equilibrium	4	105±2	Time to reach thermal equilibrium	5	20±2	Time to reach thermal equilibrium	Rated Voltage (V)		6.3	10	16	25	35	50	63	100	Z-25°C/ Z +20°C	φD<16	4	3	3	2	2	2	2	2	φD≥16	5	4	3	2	2	2	2	3	Z(-40°C/-55 °C) Z +20°C	φD<16	8	6	4	4	4	3	3	3	φD≥16	12	8	6	4	3	3	3	6
Step	Testing temperature(°C)	Time																																																																	
1	20±2	Time to reach thermal equilibrium																																																																	
2	-55(-25)±3	Time to reach thermal equilibrium																																																																	
3	20±2	Time to reach thermal equilibrium																																																																	
4	105±2	Time to reach thermal equilibrium																																																																	
5	20±2	Time to reach thermal equilibrium																																																																	
Rated Voltage (V)		6.3	10	16	25	35	50	63	100																																																										
Z-25°C/ Z +20°C	φD<16	4	3	3	2	2	2	2	2																																																										
	φD≥16	5	4	3	2	2	2	2	3																																																										
Z(-40°C/-55 °C) Z +20°C	φD<16	8	6	4	4	4	3	3	3																																																										
	φD≥16	12	8	6	4	3	3	3	6																																																										
Terminal Strength IEC-60384-4 4.4	<p><Condition></p> <p>Tensile strength of terminals. Fixed the capacitor, applied force to the terminal in lead out direction for 10± 1 seconds. Bending strength of terminals. Fixed the capacitor, applied force to bent the terminal (1~4 mm from the rubber) for 90° within 2~3 seconds, and then bent it for 90° to its original position within 2~3 Seconds.</p> <table border="1" data-bbox="402 1653 1310 1810"> <thead> <tr> <th>Diameter of lead wire</th> <th>Tensile force N (kgf)</th> <th>Bending force N (kgf)</th> </tr> </thead> <tbody> <tr> <td>0.5mm and less</td> <td>5 (0.51)</td> <td>2.5 (0.25)</td> </tr> <tr> <td>Over 0.5mm to 0.8mm</td> <td>10 (1.0)</td> <td>5 (0.51)</td> </tr> </tbody> </table> <p><Criteria></p> <p>No noticeable changes shall be found, no breakage or looseness at the terminal</p>	Diameter of lead wire	Tensile force N (kgf)	Bending force N (kgf)	0.5mm and less	5 (0.51)	2.5 (0.25)	Over 0.5mm to 0.8mm	10 (1.0)	5 (0.51)																																																									
Diameter of lead wire	Tensile force N (kgf)	Bending force N (kgf)																																																																	
0.5mm and less	5 (0.51)	2.5 (0.25)																																																																	
Over 0.5mm to 0.8mm	10 (1.0)	5 (0.51)																																																																	

ITEM	CHARACTERISTICS								
<p>Load Life Test IEC-60384-4 4.13</p>	<p><Condition> According to IEC60384-4No.4.13 methods, The capacitor is stored at a temperature of $105 \pm 2^{\circ}\text{C}$ with DC bias voltage plus the rated ripple current for 2000+48/0(1000hrs for $L \leq 7$) hours. (The sum of DC and ripple peak voltage shall not exceed the rated working voltage) Then the product should be tested after 16 hours recovering time at atmospheric conditions. The result should meet the following table: <Criteria> : The characteristic shall meet the following requirements.</p> <table border="1" data-bbox="394 725 1236 973"> <tr> <td>Leakage current</td> <td>Value in 4.2 shall be satisfied</td> </tr> <tr> <td>Capacitance Change</td> <td>Within $\pm 20\%$ of initial value</td> </tr> <tr> <td>$\tan\delta$</td> <td>Not more than 200% of the specified value.</td> </tr> <tr> <td>Appearance</td> <td>There shall be no leakage of electrolyte.</td> </tr> </table>	Leakage current	Value in 4.2 shall be satisfied	Capacitance Change	Within $\pm 20\%$ of initial value	$\tan\delta$	Not more than 200% of the specified value.	Appearance	There shall be no leakage of electrolyte.
Leakage current	Value in 4.2 shall be satisfied								
Capacitance Change	Within $\pm 20\%$ of initial value								
$\tan\delta$	Not more than 200% of the specified value.								
Appearance	There shall be no leakage of electrolyte.								
<p>Shelf Life Test IEC-60384-4 4.17</p>	<p><Condition>: The capacitors are then stored with no voltage applied at a temperature of $105 \pm 2^{\circ}\text{C}$ for 1000+48/0 hours. Following this period the capacitors shall be removed from the test chamber and be allowed to stabilize at room temperature for 4~8 hours. Next they shall be connected to a series limiting resistor ($1k \pm 100\Omega$) with D.C. rated voltage applied for 30min. After which the capacitors shall be discharged, and then, tested the characteristics. <Criteria> : The characteristic shall meet the following requirements.</p> <table border="1" data-bbox="394 1460 1236 1709"> <tr> <td>Leakage current</td> <td>Value in 4.2 shall be satisfied</td> </tr> <tr> <td>Capacitance Change</td> <td>Within $\pm 20\%$ of initial value</td> </tr> <tr> <td>$\tan\delta$</td> <td>Not more than 200% of the specified value.</td> </tr> <tr> <td>Appearance</td> <td>There shall be no leakage of electrolyte.</td> </tr> </table> <p>Remark: If the capacitors are stored more than 1 year, the leakage current may increase. Please apply voltage through about 1 K Ω resistor, if necessary.</p>	Leakage current	Value in 4.2 shall be satisfied	Capacitance Change	Within $\pm 20\%$ of initial value	$\tan\delta$	Not more than 200% of the specified value.	Appearance	There shall be no leakage of electrolyte.
Leakage current	Value in 4.2 shall be satisfied								
Capacitance Change	Within $\pm 20\%$ of initial value								
$\tan\delta$	Not more than 200% of the specified value.								
Appearance	There shall be no leakage of electrolyte.								

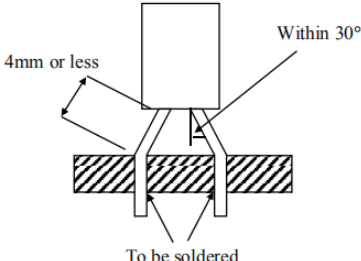
ITEM	CHARACTERISTICS								
<p>Surge Test IEC-60384-4. 4.9</p>	<p><Condition> Test temperature:15~35°C; Series resistor: $R = (100 \pm 50)/C$ R: protective resistor (KΩ); C: nominal capacitance (μF) Test voltage: Surge voltage item 4.4 No. of cycles: 1000cycles Each cycles lasts for 6 ± 0.5min “ON” for 30 ± 5 s “OFF” for 5 ± 0.5min. <Criteria></p> <table border="1" data-bbox="506 650 1316 897"> <tr> <td>Leakage current</td> <td>Not more than the specified value</td> </tr> <tr> <td>Capacitance Change</td> <td>Within $\pm 15\%$ of initial value</td> </tr> <tr> <td>tanδ</td> <td>Not more than the specified value</td> </tr> <tr> <td>Appearance</td> <td>There shall be no leakage of electrolyte.</td> </tr> </table> <p>Attention: This test simulates over voltage at abnormal situation only, and not be hypothesizing that over voltage is always applied.</p>	Leakage current	Not more than the specified value	Capacitance Change	Within $\pm 15\%$ of initial value	tanδ	Not more than the specified value	Appearance	There shall be no leakage of electrolyte.
Leakage current	Not more than the specified value								
Capacitance Change	Within $\pm 15\%$ of initial value								
tanδ	Not more than the specified value								
Appearance	There shall be no leakage of electrolyte.								
<p>Vibration Test IEC-60384-4.4.8</p>	<p><Condition> The following conditions shall be applied for 2 hours in each 3 mutually perpendicular directions. Vibration frequency range : 10Hz ~ 55Hz; Peak to peak amplitude : 1.5mm Sweep rate : 10Hz ~ 55Hz ~ 10Hz in about 1 minute Mounting method: The capacitor with diameter greater than 12.5mm or longer than 25mm must be fixed in place with a bracket.</p>  <p><Criteria> After the test, the following items shall be tested:</p> <table border="1" data-bbox="399 1707 1290 1926"> <tr> <td>Inner construction</td> <td>No intermittent contacts, open or short circuiting. No damage of tab terminals or electrodes</td> </tr> <tr> <td>Appearance</td> <td>No mechanical damage in terminal. No leakage of electrolyte or swelling of the case. The markings shall be legible</td> </tr> </table>	Inner construction	No intermittent contacts, open or short circuiting. No damage of tab terminals or electrodes	Appearance	No mechanical damage in terminal. No leakage of electrolyte or swelling of the case. The markings shall be legible				
Inner construction	No intermittent contacts, open or short circuiting. No damage of tab terminals or electrodes								
Appearance	No mechanical damage in terminal. No leakage of electrolyte or swelling of the case. The markings shall be legible								

ITEM	CHARACTERISTICS								
Solderability Test IEC-60384-4 4.6	<p><Condition></p> <p>The capacitor shall be tested under the following conditions:</p> <p>Soldering temperature : 245±3°C;</p> <p>Dipping depth : 2mm ;</p> <p>Dipping speed : 25±2.5mm/s</p> <p>Dipping time : 3±0.5s</p> <p><Criteria> : Coating quality : A minimum of 95% of the surface being immersed</p>								
Resistance To Solder Heat Test IEC-60384-4 4.5	<p><Condition></p> <p>Terminals of the capacitor shall be immersed into solder bath at 260±5°C for 10±1 seconds or 400±10°C for 3~4 seconds to 1.5~2.0mm from the body of capacitor. Then the capacitor shall be left under the normal temperature and normal humidity for 1~2 hours before measurement.</p> <p><Criteria></p> <table border="1" data-bbox="498 1033 1293 1282"> <tr> <td>Leakage current</td> <td>Not more than the specified value</td> </tr> <tr> <td>Capacitance Change</td> <td>Within ± 10% of initial value</td> </tr> <tr> <td>tanδ</td> <td>Not more than the specified value</td> </tr> <tr> <td>Appearance</td> <td>There shall be no leakage of electrolyte.</td> </tr> </table>	Leakage current	Not more than the specified value	Capacitance Change	Within ± 10% of initial value	tanδ	Not more than the specified value	Appearance	There shall be no leakage of electrolyte.
Leakage current	Not more than the specified value								
Capacitance Change	Within ± 10% of initial value								
tanδ	Not more than the specified value								
Appearance	There shall be no leakage of electrolyte.								
Damp Heat Test IEC-60384-4 4.12	<p><Condition></p> <p>Humidity test: According to IEC60384-4 No.4.12 methods, capacitor shall be exposed for 500±8 hours in an atmosphere of 90~95%RH .at 40±2°C, the characteristic change shall meet the following requirement.</p> <p><Criteria></p> <table border="1" data-bbox="476 1638 1293 1887"> <tr> <td>Leakage current</td> <td>Not more than the specified value.</td> </tr> <tr> <td>Capacitance Change</td> <td>Within ± 20% of initial value..</td> </tr> <tr> <td>tan δ</td> <td>Not more than 120% of the specified value.</td> </tr> <tr> <td>Appearance</td> <td>There shall be no leakage of electrolyte.</td> </tr> </table>	Leakage current	Not more than the specified value.	Capacitance Change	Within ± 20% of initial value..	tan δ	Not more than 120% of the specified value.	Appearance	There shall be no leakage of electrolyte.
Leakage current	Not more than the specified value.								
Capacitance Change	Within ± 20% of initial value..								
tan δ	Not more than 120% of the specified value.								
Appearance	There shall be no leakage of electrolyte.								

ITEM	CHARACTERISTICS																
<p>Change Of Temperature Test IEC-60384-4 4.7</p>	<p><Condition> Temperature cycle: According to IEC60384-4 No.4.7 methods, capacitor shall be placed in an oven, the condition according as below:</p> <table border="1" data-bbox="458 441 1300 700"> <thead> <tr> <th>Temperature</th> <th>Time</th> </tr> </thead> <tbody> <tr> <td>(1) +20°C</td> <td>≤ 3 Minutes</td> </tr> <tr> <td>(2) -55°C</td> <td>30 ± 2 Minutes</td> </tr> <tr> <td>(3) +105°C</td> <td>30 ± 2 Minutes</td> </tr> <tr> <td colspan="2">(1) To (3) = 1 cycle, Total 5 Cycles</td> </tr> </tbody> </table> <p><Criteria> The characteristic shall meet the following requirement.</p> <table border="1" data-bbox="458 828 1300 986"> <tbody> <tr> <td>Leakage current</td> <td>Not more than the specified value.</td> </tr> <tr> <td>Tan δ</td> <td>Not more than the specified value.</td> </tr> <tr> <td>Appearance</td> <td>There shall be no leakage of electrolyte.</td> </tr> </tbody> </table>	Temperature	Time	(1) +20°C	≤ 3 Minutes	(2) -55°C	30 ± 2 Minutes	(3) +105°C	30 ± 2 Minutes	(1) To (3) = 1 cycle, Total 5 Cycles		Leakage current	Not more than the specified value.	Tan δ	Not more than the specified value.	Appearance	There shall be no leakage of electrolyte.
Temperature	Time																
(1) +20°C	≤ 3 Minutes																
(2) -55°C	30 ± 2 Minutes																
(3) +105°C	30 ± 2 Minutes																
(1) To (3) = 1 cycle, Total 5 Cycles																	
Leakage current	Not more than the specified value.																
Tan δ	Not more than the specified value.																
Appearance	There shall be no leakage of electrolyte.																
<p>Vent Test IEC-60384-4 4.16</p>	<p><Condition> The following test only apply to those products with vent products at diameter ≥∅ 6.3 with vent. D.C. test: The capacitor is connected with its polarity reversed to a DC power source. Then a current selected from Table 2 is applied.</p> <table border="1" data-bbox="444 1338 1300 1462"> <thead> <tr> <th>Diameter (mm)</th> <th>DC Current (A)</th> </tr> </thead> <tbody> <tr> <td>22.4 or less</td> <td>1</td> </tr> </tbody> </table> <p><Criteria> The vent shall operate with no dangerous conditions such as flames or dispersion of pieces of the capacitor and/or case.</p>	Diameter (mm)	DC Current (A)	22.4 or less	1												
Diameter (mm)	DC Current (A)																
22.4 or less	1																

FORMING DIMENSION - Unit : mm

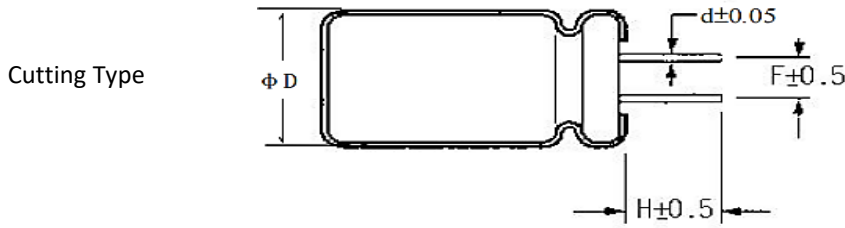

Shape Code	D	5.0	6.3	8.0	10~13	16~18
CB Cutting- 3.5mm	F	2.0	2.5	3.5	5.0	7.5
	H	3.5	3.5	3.5	3.5	3.5
	d	0.5	0.5	0.5	0.6	0.8

Shape Code	D	5.0	6.3	8.0	10~13	16~18
CC Cutting- 4.0mm	F	2.0	2.5	3.5	5.0	7.5
	H	4.0	4.0	4.0	4.0	4.0
	d	0.5	0.5	0.5	0.6	0.8

Shape Code	D	5.0	6.3	8.0	10~13	16~18
CD Cutting- 4.5mm	F	2.0	2.5	3.5	5.0	7.5
	H	4.5	4.5	4.5	4.5	4.5
	d	0.5	0.5	0.5	0.6	0.8

Shape Code	D	5.0	6.3	8.0	10~13	16~18
CE Cutting- 5.0mm	F	2.0	2.5	3.5	5.0	7.5
	H	5.0	5.0	5.0	5.0	5.0
	d	0.5	0.5	0.5	0.6	0.8

KD FORMING DIMENSION - Unit : mm

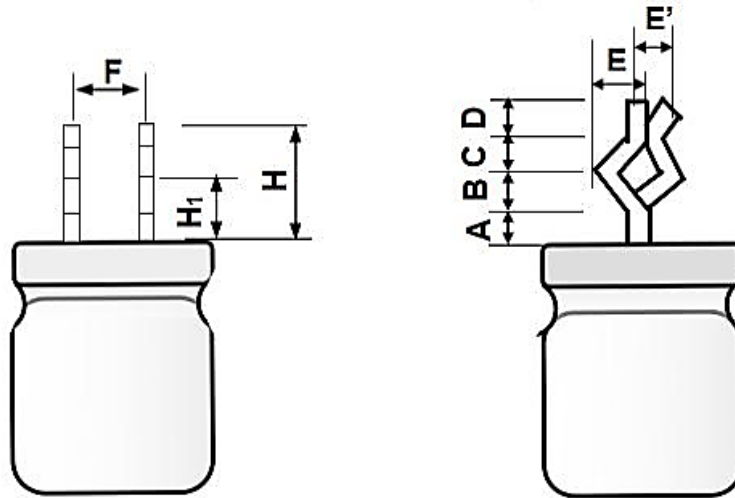

ϕD	10	16
F	5.0 ± 0.5	7.5 ± 0.5
H	4.5 ± 0.5	4.5 ± 0.5
H ₁	2.0 ± 0.3	2.0 ± 0.3
A	1.0 ± 0.3	1.0 ± 0.3
B	1.0 ± 0.3	1.0 ± 0.3
C	1.0 ± 0.3	1.0 ± 0.3
D	1.5 ± 0.5	1.5 ± 0.5
E	1.3 ± 0.3	1.3 ± 0.3
E'	1.0 Max.	1.0 Max.

TAPING DIMENSION - Unit : mm

Taping Code \ Item	Symbol	T2	TB	T3	T5
		Fig 1			
Diameter	D	5	6.3	8	10 12.5/ 13
Height	L	9~30			
Lead Diameter	$d \pm 0.05$	0.5	0.5/0.6		0.6
Component Spacing	$P \pm 1.0$	12.7			15.0
Pitch of sprocket holes	$P0 \pm 0.2$	12.7			15.0
Distance between centers of terminal and the sprocket holes	$P1 \pm 0.5$	5.1	4.6		3.85
Feed hole center to component center	$P2 \pm 1.0$	6.35			7.5
Distance between centers of component leads	$F \pm 0.5$	2.0	2.5	3.5	5.0
Carrier tape width	$W \pm 1.0$	18			
Hold down tape width	W0	7 Min.			
Distance between the center of upper edge of carrier tape and sprocket hole	$W1 \pm 0.5$	9			
Distance between the upper edges of the carrier tape and the hold down tape	W2	3.0 Max.			
Distance between the abscissa and the bottom of the components body	$H \pm 1.0$	18.5	18.5		18.5
Distance between the abscissa and the reference plane of the components with crimped leads	$H0 \pm 0.5$	/			
Max. lateral deviation of the component body vertical to the tape plane	Δh	2.0 Max.			
End of lead	L1	0.5 Max.			
Diameter of driving hole	D0	4.0 ± 0.2			
Sun of thickness for mounting and adhesive tape without lead Diameter	t	0.6 ± 0.3			

TAPING DIMENSION - Unit : mm

Taping Code	Item	Symbol	TF	T7	
			Fig 2		
Diameter	D		12.5/13.0	16	18
Height	L		9~30		
Lead Diameter	$d \pm 0.05$		0.6	0.8	
Component Spacing	$P \pm 1.0$		25.4	30.0	
Pitch of sprocket holes	$P0 \pm 0.2$		12.7	15.0	
Distance between centers of terminal and the sprocket holes	$P1 \pm 0.5$		3.85	3.75	
Feed hole center to component center	$P2 \pm 1.0$		6.35	7.50	
Distance between centers of component leads	$F \pm 0.5$		5.0	7.5	
Carrier tape width	$W \pm 1.0$		18.0		
Hold down tape width	W0		7.0 Min.		
Distance between the center of upper edge of carrier tape and sprocket hole	$W1 \pm 0.5$		9.0		
Distance between the upper edges of the carrier tape and the hold down tape	W2		3.0 Max.		
Distance between the abscissa and the bottom of the components body	$H \pm 1.0$		18.5		
Distance between the abscissa and the reference plane of the components with crimped leads	$H0 \pm 0.5$		/		
Max. lateral deviation of the component body vertical to the tape plane	Δh		2.0 Max.		
End of lead	L1		0.5 Max.		
Diameter of driving hole	D0		4.0 ± 0.2		
Sun of thickness for mounting and adhesive tape without lead Diameter	t		0.6 ± 0.3		

TAPING DIMENSION - Unit : mm

Taping Code \ Item	Symbol	TB	T5	TB	T5	TB	T5
		Fig 4	Fig 3	Fig 4	Fig 3	Fig 4	Fig 3
Diameter	D	4		5			
Height	L	5/7				9~12	
Lead Diameter	$d \pm 0.05$	0.45				0.50	
Component Spacing	$P \pm 1.0$	12.7					
Pitch of sprocket holes	$P0 \pm 0.2$	12.7					
Distance between centers of terminal and the sprocket holes	$P1 \pm 0.5$	5.1	3.85	5.1	3.85	5.1	3.85
Feed hole center to component center	$P2 \pm 1.0$	6.35					
Distance between centers of component leads	$F \pm 0.5$	2.5	5.0	2.5	5.0	3.5	5.0
Carrier tape width	$W \pm 1.0$	18					
Hold down tape width	W0	7 Min.					
Distance between the center of upper edge of carrier tape and sprocket hole	$W1 \pm 0.5$	9					
Distance between the upper edges of the carrier tape and the hold down tape	W2	3.0 Max.					
Distance between the abscissa and the bottom of the components body	$H \pm 0.75$	18.5	17.5	18.5	17.5	18.5	17.5
Distance between the abscissa and the reference plane of the components with crimped leads	$H0 \pm 0.5$	/	16.0	/	16.0	/	16.0
Max. lateral deviation of the component body vertical to the tape plane	Δh	2.0 Max.					
End of lead	L1	0.5 Max.					
Diameter of driving hole	D0	4.0 ± 0.2					
Sum of thickness for mounting and adhesive tape without lead Diameter	t	0.6 ± 0.3					

TAPING DIMENSION - Unit : mm

Taping Code \ Item	Symbol	T5					
		Fig 3					
Diameter	D	6.3		8			
Height	L	5/7	9/12	5	7	9~19	20~25
Lead Diameter	$d \pm 0.05$	0.45	0.50	0.45	0.45	0.50	0.60
Component Spacing	$P \pm 1.0$	12.7					
Pitch of sprocket holes	$P0 \pm 0.2$	12.7					
Distance between centers of terminal and the sprocket holes	$P1 \pm 0.5$	3.85			4.6		
Feed hole center to component center	$P2 \pm 1.0$	6.35					
Distance between centers of component leads	$F \pm 0.5$	5.0					
Carrier tape width	$W \pm 1.0$	18					
Hold down tape width	W0	7 Min.					
Distance between the center of upper edge of carrier tape and sprocket hole	$W1 \pm 0.5$	9					
Distance between the upper edges of the carrier tape and the hold down tape	W2	3.0 Max.					
Distance between the abscissa and the bottom of the components body	$H \pm 0.75$	17.5		20			
Distance between the abscissa and the reference plane of the components with crimped leads	$H0 \pm 0.5$	16.0					
Max. lateral deviation of the component body vertical to the tape plane	Δh	2.0 Max.					
End of lead	L1	0.5 Max.					
Diameter of driving hole	D0	4.0 ± 0.2					
Sun of thickness for mounting and adhesive tape without lead Diameter	t	0.6 ± 0.3					

STRAIGHT FOOT BRAID

Fig 1

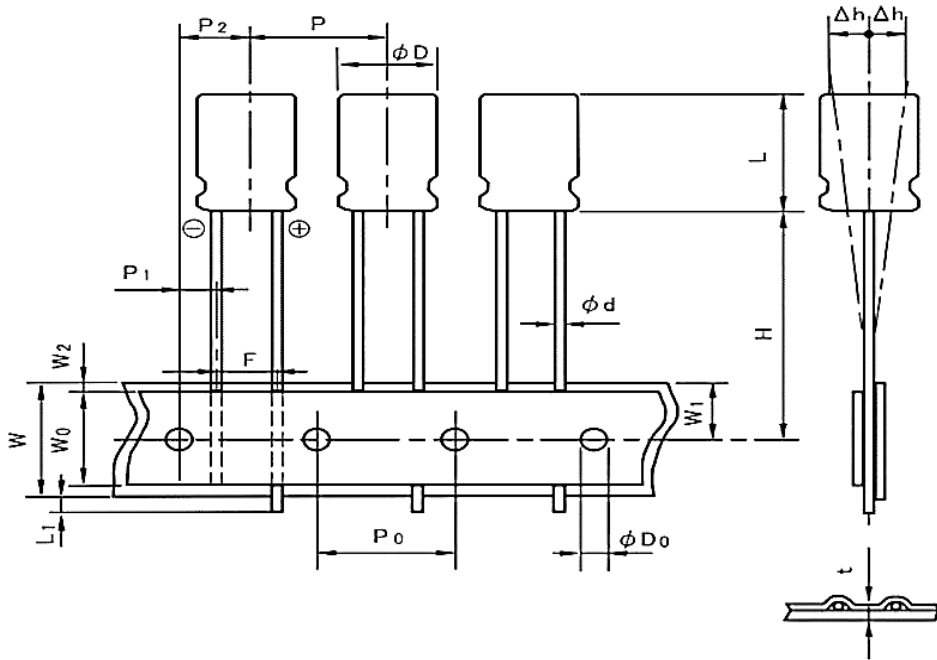
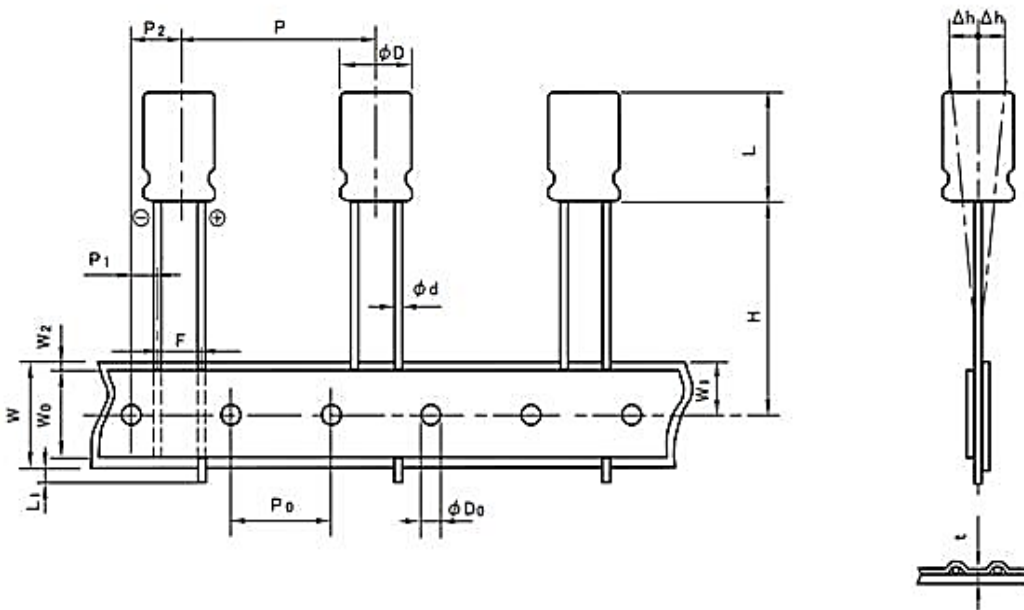

Fig 2



STRAIGHT FOOT BRAID

Fig 3

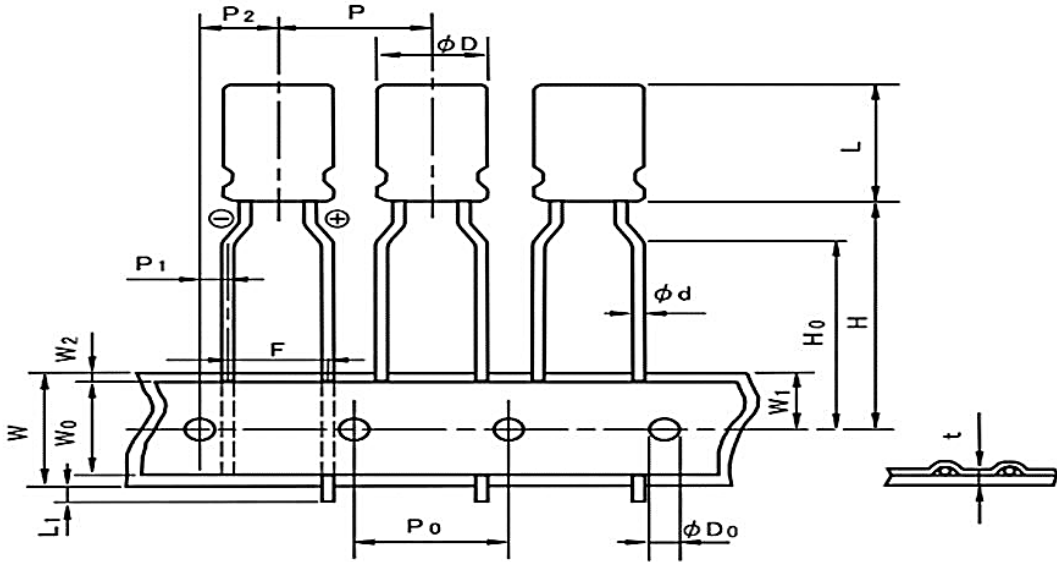
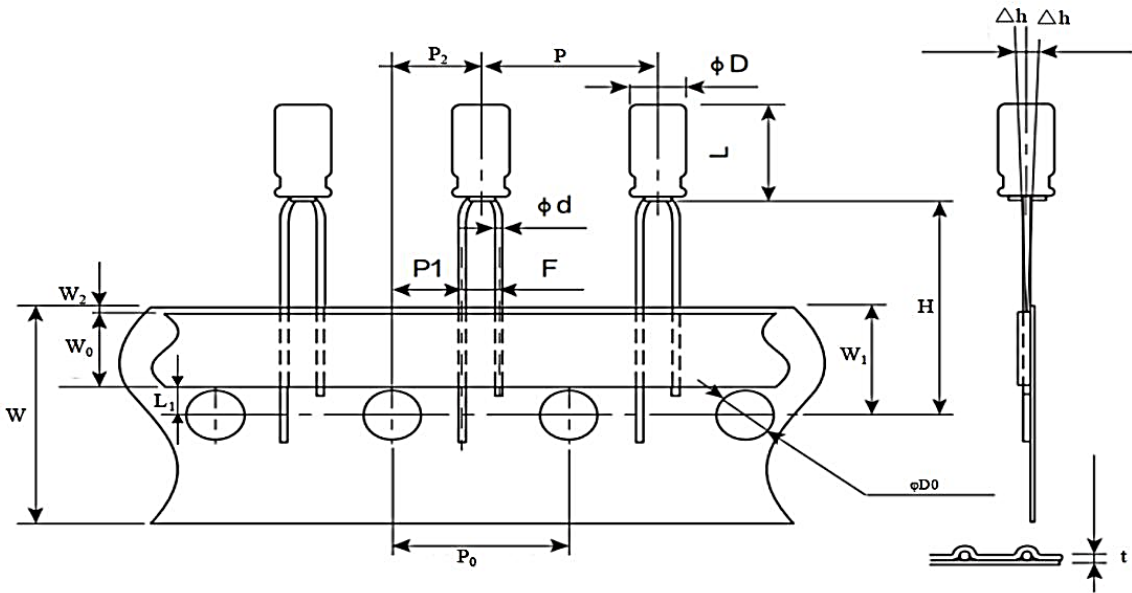

Fig 4



ATTENTION

When using Aluminum Electrolytic Capacitor, please pay attention to the points listed below. If the following types of electrical loads are applied to Aluminum Electrolytic Capacitor, rapid deterioration of electrical property occurs:

- Reverse voltage
- Overvoltage exceeding rated working voltage
- Current exceeding rated ripple current
- Severe charging/discharging

At such times, severe heat is generated, gas is emitted, then electrolyte leaks from the sealed area, and pressure relief vent operates due to increase of internal pressure. In the worst case, explosion or ignition may occur, and along with destruction of the capacitor combustibles may burst out.

CAUTION DURING CIRCUIT DESIGN

1. Operational environments, mounting environment and conditions. Ensure that operational and mounting conditions follow the specified conditions detailed in the catalog and specification sheets
2. Operating temperature, ripple current and load life. Operating temperature and applied ripple current should be within the specified value in the catalog or specification sheets. Do not use Aluminum Electrolytic Capacitors at temperature which exceeds the specified category temperatures range. Do not apply excessive current to the capacitors, which exceeds the specified rated ripple current. During circuit design, please ensure that capacitors are selected to match with the lifetime requirements of the application
3. Application: Aluminum Electrolytic Capacitors are normally polarized. Reverse voltage or AC Voltage should not be applied. When polarity may flip over, non-polar type should be used, but the non-polar type cannot be used for AC. Standard Aluminum Electrolytic Capacitors are not suitable for rapid charge and discharge applications. Group in your area about specialty signed capacitors for rapid charge and discharge.
4. Applied Voltage: Do not exceed the rated voltage of capacitors

5. Insulation: Aluminum Electrolytic Capacitors should be electrically isolated from the following. Aluminum case, cathode lead wire, anode lead wire and circuit pattern; Auxiliary terminals of snap-in type, anode terminal, outward terminals and circuit pattern. The PVC sleeve of Aluminum Electrolytic Capacitors is not recognized as an insulator, and therefore, the standard capacitor should not be used in a place where insulation function is needed. Please consult with NextGen Components, Inc. if you require a higher grade of insulating sleeve.
6. Conditions of use: The following environments should be avoided when using Aluminum Electrolytic Capacitors. Damp conditions such as water, salt water or oil spray or fumes, high humidity or humidity condensation situations. Hazardous gas/fumes such as hydrogen sulfide, sulfurous acid gas, nitrous acid, chlorine gas, ammonia or bromine gas; Exposure of ozone, ultraviolet rays or radiation; Severe vibration or shock which exceeds the condition specified in the catalog or specification sheet.
7. Consideration to assembly condition: In designing a circuit, the following matters should be ensured in advance to the capacitor's assembly on the printed circuit board (PC board) Design the appropriate hole spacing to match the lead pitch of capacitors; Do not locate any wiring and circuit patterns directly above the capacitor's vent; Ensure enough free space above the capacitor's vent. The recommended space is specified in the catalog or specification sheets; In case the capacitor's vent is facing the PC board, make a gas release hole on PC board. The sealing side of the screw terminal type should not face down in the application. When the capacitors are mounted horizontally, the anode screw terminals must be positioned at upper side.
8. Consideration to circuit design: Any copper lines or circuit patterns should not be laid under the capacitor; Parts which radiate heat should not be placed close to the reverse side of the Aluminum Electrolytic Capacitors on the PC board.

9. Others

Performance of electrical characteristics of Aluminum Electrolytic Capacitors is affected by variation of operating temperature and frequency. Consider this variation when designing the circuit. Excessive holes and connection hole between both sides on the PC board should be avoided around or under the mounting area of the Aluminum Electrolytic Capacitors on double sided or multilayer PC board. Torque of tightening screw terminals should not exceed the specified maximum value which is described in the catalog and specification sheets . Consider current balance when 2 or more Aluminum Electrolytic Capacitors are connected in parallel. Use bleeding resistors when 2 or more Aluminum Electrolytic Capacitors are connected in series .In this case, the resistors should be connected parallel to the capacitors.

CAUTION FOR ASSEMBLING CAPACITORS

1. Caution before assembly : Aluminum Electrolytic Capacitors cannot be recycled after mounting and applying electricity in unit. The capacitors, which are removed from PC board for the purpose of measuring electrical characteristics at the periodical inspection, should only be recycled for the same position.; Aluminum Electrolytic Capacitors may accumulate charge naturally during storage. In this case, discharge through a 1KOHM resistor before use; Leakage current of Aluminum Electrolytic Capacitors may be increased during long storage time. In this case, the capacitors should be subject to voltage treatment through a 1KOHM resistor before use.
2. In the assembly process-1: Ensure rated voltage and capacitance of the capacitors before mounting; Ensure capacitors polarity before mounting; Do not use a capacitor which has been dropped onto a hard surface; Do not use a capacitor with damaged or dented cased or seals.
3. In the assembly process-2: Capacitors should be mounted after confirmation that hole spacing on PC board matches the lead pitch of the capacitors; The snap-in type of capacitors should be mounted firmly on the PC board without a gap between the capacitor body and the surface of PC board; Avoid excessive force when clinching lead wire during auto-insertion process; Avoid excessive shock to capacitors by automatic inserting machine, during mounting, parts inspection or centering operations; Please utilize supporting material such as strap of adhesive to mount capacitors to PC board when it is anticipated that vibration or shock is applied.

4. Soldering: Soldering conditions (temperature and time) should be within the specified conditions which are described in the catalog or specification sheets; In case lead wire reforming is needed due to inappropriate pitch between capacitor and holes on PC board, stress to the capacitor should be avoided; In case of maintenance by soldering iron, if it is required to detach the capacitor, it should be removed from PC board after solder has melted sufficiently in order to reduce stress on the lead wires/terminals of the capacitor; Soldering iron should never touch the capacitor's body.
5. Flow soldering: Do not dip capacitor's body into melted solder. It should only be soldered on the reverse side of the PC board on which the capacitors are mounted; Soldering condition (preheat, soldering temperature, dipping time) should be within the specified standard which is described in the catalog or specification sheets; Flux should not be adhered to capacitor's body but only to its terminals; Other devices which are mounted close to capacitors should not touch the capacitors.
6. Reflow soldering: Reflow soldering conditions (preheat, soldering, temperature, reflow time) should follow the specified standard which is described in the catalog or specification sheets; Heating standard should depend on surface of the capacitor color or materials when infrared rays are used because the capacitor's heat absorption depends on the surface color or materials. Check heat condition; Standard Aluminum Electrolytic Capacitors cannot withstand two or more reflow processes.
7. Handling after soldering: Do not bend or twist the capacitor's body after soldering on PC board; Do not pick-up or move PC board by holding the soldered capacitors; Do not hit the capacitors and isolate capacitors from the PC board or other device when stacking PC boards in store.
8. PC board cleaning: Standard Aluminum Electrolytic Capacitors should be free from halogenated solvents during PC board cleaning after soldering
9. Adhesives and coating materials: Do not use halogenated adhesives and coating materials to fix Aluminum Electrolytic Capacitors; Flux between the surface of the PC board and sealing of capacitors should be cleaned before using adhesives or coating materials; Solvents should be dried up before using adhesives or coating materials; Do not cover up all the sealing area of capacitors with adhesives or coating materials, make coverage only partial.

CAUTION DURING USE OF CAPACITORS IN SETS

1. Do not touch the terminals of capacitors;
2. Do not connect electrical terminals of the capacitors. Keep the capacitors free from conductive solution, such as acid, alkali and so on;
3. Ensure the operational environment of the equipment in which the capacitor has been built is within the specified condition mentioned in the catalog or specification sheets.

MAINTENANCE

1. Periodical inspection should be carried out for the capacitors, which are used with industrial equipment. Check the following points at the inspection.
2. Visual inspection to check pressure relief vent open or leakage of electrolyte.
3. Electrical characteristics: leakage current, capacitance, dissipation factor and the other points which are mentioned in the catalog or specification sheets.

EMERGENCY ACTION

1. If the pressure relief vent is open and some gas blows out from the capacitor, turn the main switch of the equipment off or pull out the plug from the power outlet immediately.
2. During pressure relief vent operation, extremely hot gas (over 100°C) may blow out from the vent area of the capacitors. So keep your face and skin away from capacitors during its operation. In case of eye contact, flush the open eye(s) with large amount of clean water immediately. In case of ingestion, gargle with water immediately, and do not swallow. Also do not touch electrolyte but wash skin with soap and water in case of skin contact.

STORAGE CONDITIO

1. Aluminum Electrolytic Capacitors should not be stored in high temperature or in high humidity. The suitable storage condition is 5°C-35°C, and less than 75% in relative humidity;
2. Aluminum Electrolytic Capacitors should not be stored in damp conditions such as water, salt water spray or oil spray.

3. Do not store Aluminum Electrolytic Capacitors in an environment full of hazardous gas (hydrogen sulfide gas, sulfuric acid gas, nitrous acid, chlorine gas, ammonia or bromine gas).
4. Aluminum Electrolytic Capacitors should not be stored under exposure to ozone, ultraviolet rays or radiation.
5. After one year, a capacitor should be reconditioned by applying rated voltage in series with a 1000Ω current limiting resistor for a time period of 30 minutes.

DISPOSAL

Please take either of the following actions in case of disposal. Incineration (high temperature of more than 800°C) after crushing the capacitor's body; Consignment to specialists of industrial waste.

IMPORTANT NOTES AND DISCLAIMER

1. **ROHS COMPLIANCE:** The levels of RoHS restricted materials in this product are below the maximum concentration values (also referred to as the threshold limits) permitted for such substances, or are used in an exempted application, in accordance with EU RoHS Directive (EU) 2015/863 EC (RoHS3). RoHS Test Report for this product can be obtained at Download Center.
2. **REACH COMPLIANCE:** REACH substances of high concern (SVHCs) information is available for this product. Since the European Chemical Agency (ECHA) has published notice of their intent to frequently revise the SVHC listing for the foreseeable future, REACH Test Report for this product can be obtained at Download Center.
3. All Product parametric performance is indicated in the Electrical Characteristics for the listed herein test conditions, unless otherwise noted. Product performance may not be indicated by the Electrical Characteristics if operated under different conditions.
4. NextGen Component, Inc (*NextGen*) reserves the right to make changes to this document and its products and specifications at any time without notice. Customers should obtain and confirm the latest product information and specifications before final design, purchase or use.
5. *NextGen* makes no warranty, representation or guarantee regarding the suitability of its products for any particular purpose, not does *NextGen* assume any liability for application assistance or customer product design.
6. *NextGen* does not warrant or accept any liability with products which are purchased or used for any unintended or unauthorized application. No license is granted by implication or otherwise under any intellectual property rights of NextGen.
7. *NextGen* products are not authorized for use as critical components in life support devices or systems without express written approval by *NextGen*.
8. *NextGen* requires that customers first obtain an RMA (Returned Merchandise Authorization) number prior to returning any products. Returns must be made within 30 days of the date of invoice, be in the original packaging, unused and like-new condition. At the time of quoting or purchasing, a product may say that it is Non-Cancelable/ Non-Returnable (NCNR). These products are not returnable and not refundable.