



<b>SPECIFICATION SHEET NO.</b>	R1108- ZH228M025HQOTA	
<b>ORIGINAL MFG/PART NO.</b>	Aillen Capacitors/CAE228M1EHZHK1FTR	
<b>NEXTGEN PART CODE</b>	ZH228M025HQOTA	Indicate This Code For <a href="#">RFQ</a> /Order
<b>DATE</b>	Nov. 8, 2024	
<b>REVISION</b>	A6	Updated With Most Recent Data
<b>DESCRIPTION AND MAIN PARAMETRICS</b>	<p>SMD Capacitors Aluminum Electrolytic (CAE), ZH series, 2 pads  Wide Temperature and Low Impedance Type  Capacitance: 2200μF, Tolerance ±20%, Voltage 25V  Case size: Ø16.0*L16.5mm, Impedance (Ω/20°C,100KHz): 0.054Ω Max.  Ripple Current (mA r.m.s./@+105°C, 100KHz): 1260mA Max.  Load Life @105°C: 5000 Hours, Operating Temp. Range -55°C ~+105°C  REACH/RoHS/RoHS III Compliant &amp; Halogen Free  Package in Tape/Reel, 200pcs/Reel</p>	
<b>CUSTOMER</b>		
<b>CUSTOMER PART NUMBER</b>		
<b>CROSS REF. PART NUMBER</b>		
<b>MEMO</b>		

<b>VENDOR APPROVE</b>		
Issued/Checked/Approved		
		
Nov. 8, 2024		

<b>CUSTOMER APPROVE</b>
DATE:

## MAIN FEATURE

- Aluminum Electrolytic Capacitors Foil Type, Radial, Can – SMD
- Wide Temperature And Low Impedance Type
- High Stability And Reliability and Designed Capacitors Quality Meets IEC60384
- Leakage Current  $I \leq 0.01CV$  Or  $3(\mu A)$  Whichever Is Greater After 2 Minutes
- Operating Temperature Range:  $-55 \sim +105^{\circ}C$
- Rated Voltage Range from 6.3V to 100V
- Offer Quality Alternatives Parts For Major Brand KEMET/CHEMI-CON/NICHICON /RUBYCON and more
- Moisture Sensitivity Level (MSL) 1 (Unlimited)
- REACH/RoHS/RoHS III Compliant & Halogen Free
- MSDS Data Sheet Available

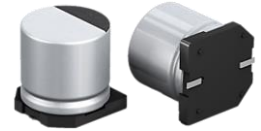

*Image shown is a representation only. Exact specifications should be obtained from the product dimension.*

## MAIN APPLICATION

- High-density Patch Assembly Electronic Circuit: Power Supply, Lighting, etc
- Industrial Equipment: Routers, Switches, Measuring Instruments, etc.
- Consumption Type Equipment: Amplifying Circuit Of Intelligent Loudspeaker, Smoothing Circuit, LED Lamp, etc.

## ELECTRICAL CHARACTERISTICS

- See Page 7 ~ Page 14 For Different Part Number.
- All Products Parameters are Subject To NextGen Components' Final Confirmation.



## HOW TO ORDER

- Please Follow Up Part Code Guide And Indicate Part Code ZH228M025HQOTA For RFQ/Order.

**RFQ**

[Request For Quotation](#)

## PART CODE GUIDE

CODE	NAME	KEY SPECIFICATION OPTION
ZH	Product Index	Capacitors Aluminum Electrolytic, V-Chip Type, Original Series Number CDVZH
228	Rated Capacitance	105: 1.0μF; 225: 2.2μF; 335: 3.3μF; 475: 4.7μF; 106: 10μF; 226: 22μF; 336: 33μF; 476: 47μF; 686: 68μF; 107: 100μF; 157: 150μF; 227: 220μF; 337: 330μF; 477: 470μF; 687: 680μF; 108: 1000μF; 158: 1500μF; 228: 2200μF; 338: 3300μF
M	Capacitance Tolerance	M: ±20%; V: -10% ~ +20%
025	Rated Voltage	6V3: 6.3V; 010: 10V; 016:16V; 025: 25V; 035: 35V; 050: 50V; 063: 63V; 080: 80V; 100: 100V
H	Environmental Requirements	R: RoHS III Compliant; H: RoHS III Compliant & Halogen Free
Q	Case Diameter	C: Ø4.0mm; D: Ø5.0mm; E: Ø6.3mm; F: Ø8.0mm; G: Ø10.0mm; P: Ø 12.5mm; Q: Ø16mm
O	Case Length	H: L5.7mm; I: L6.5mm; J: L7.7mm; K: L10.2mm; N: L13.5mm; O:L16.5mm; R: L21.5mm
T	Package	T: Tape/Reel
A	Internal Control Code	Letter A~Z
XX	Suffix	Blank: N/A XX: Letter A~Z, a~z or digits (0~9) for Special/Custom Parameters

**DIMENSION** (Unit: mm,  $\varnothing 4 \sim \varnothing 6.3$  Non Explosion Proof Valve;  $\varnothing 8 \sim \varnothing 10$  Explosion Proof Valve)

• Fig 1:  $\varnothing 4 \sim \varnothing 10$

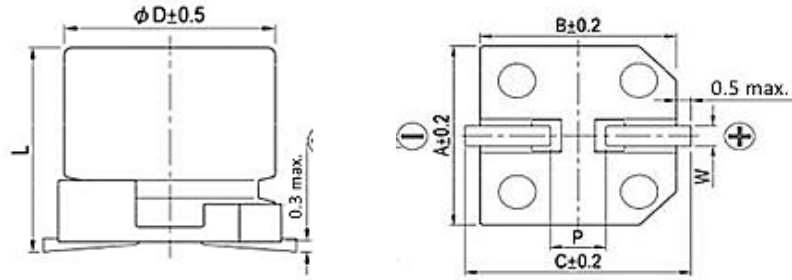

• Fig 2:  $\geq \varnothing 12.5$

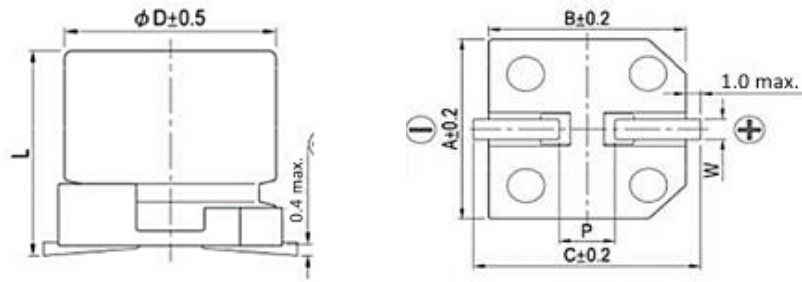

Case D.	$\varnothing 4$	$\varnothing 5$	$\varnothing 6.3$	$\varnothing 6.3$	$\varnothing 6.3$	$\varnothing 8$	$\varnothing 8$	$\varnothing 10$	$\varnothing 12.5$	$\varnothing 16$	$\varnothing 18$
Case L.	5.4	5.4/5.7	5.4/5.7	5.8	7.7	6.5	10.2/10.5		13.5	16.5	16.5
Tol. @ L	-0.3~+0.5					±0.5				±0.4	±0.5
A	4.3	5.3	6.6	6.6	6.6	8.3	8.3	10.3	13	17	19
B	4.3	5.3	6.6	6.6	6.6	8.3	8.3	10.3	13	17	19
C	5.1	6.0	7.2	7.2	7.2	9.0	9.2	11.2	14	18	20
P±0.2	1.0	1.5	2.1	2.1	2.1	3.1	3.1	4.5	4.4	6.4	6.4
W	0.5~0.8					0.7~1.2		0.7~1.3	1.1~1.4		

**MARKING**

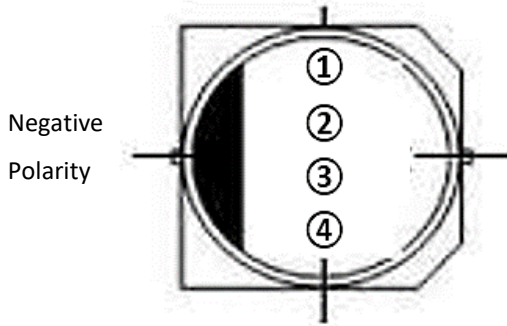

SYMBOL	NAME
①	Blank: N/A Letter (A~Z) + Digits (1~10): QC Code
②	Series Code
③	Capacitance
④	Rated Voltage

**RECOMMENDED LAND PATTERN** (Unit: mm)

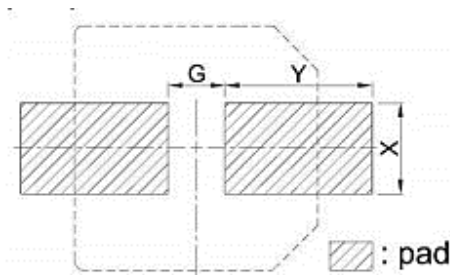

DIAMETER SIZE	X	Y	G
Ø4	1.6	2.6	1.0
Ø5	1.6	3.0	1.4
Ø6.3	1.6	3.5	1.9
Ø8	2.5	3.5	3.0
Ø10	2.5	4.0	4.0
Ø12.5	3.2	6.0	4.0
Ø16	3.2	7.0	6.0
Ø18	3.2	8.0	6.0

**CONSTRUCTION**

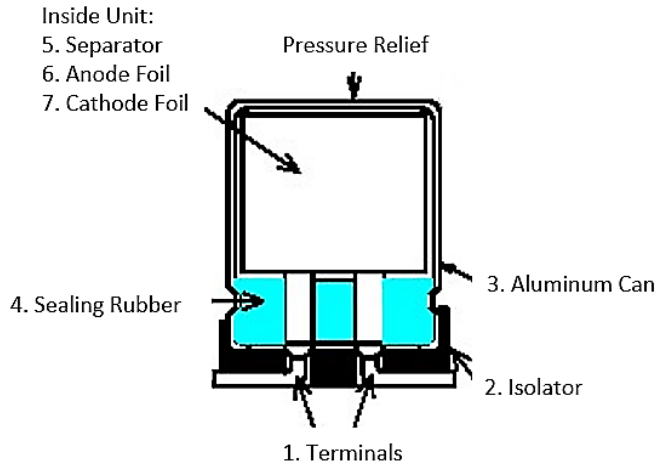

NO.	PARTS	MATERIAL
1	Terminal	Tinned Copper – Clad Steel Wire (Pb Free)
2	Isolator	Thermo-plastic resin
3	Aluminum Can	Aluminum
4	Sealing Rubber	Synthetic rubber
5	Separator	Manila hemp
6	Anode Foil	High purity aluminum foil
7	Cathode Foil	Aluminum foil

**GENERAL ELECTRICAL CHARACTERISTICS – FOR DIFFERENT PART CODE**

PARAMETER	UNITS	VALUE
Operating Junction Temperature Range	°C	-55 ~ +105
Storage Temperature Range	°C	-55 ~ +150

**FREQUENCY COEFFICIENT OF ALLOWABLE RIPPLE CURRENT**

FREQUENCY	50Hz	60Hz	120Hz	1KHz	≥10KHz
Coefficient	0.6	0.6	0.7	0.85	1

**TEMPERATURE COEFFICIENT**

AMBIENT TEMPERATURE (°C)	105	85	≤70
Coefficient	1	1.5	2

**ELECTRICAL CHARACTERISTICS** - Ta = 25°C, FOR DIFFERENT PART CODE

NEXTGEN PART CODE	ORIGINAL PART NUMBER	RATE VOL.	CAPACITOR VALUE	MAX. IMPEDANCE @20 °C 100KHZ	MAX. RIPPLE CURRENT @ 105°C 100KHZ	CASE SIZE ØD X L
		V	µF	mΩ	mA r.m.s	mm
ZH226M6V3HCHTA	CAE226M0JHZHCE7TR	6.3	22	1.35	80	4x5.7
ZH336M6V3HCHTA	CAE336M0JHZHCE7TR	6.3	33	1.35	80	4x5.7
ZH476M6V3HDHTA	CAE476M0JHZHDE7TR	6.3	47	0.8	150	5x5.7
ZH107M6V3HEHTA	CAE107M0JHZHEE7TR	6.3	100	0.44	230	6.3x5.7
ZH157M6V3HEHTA	CAE157M0JHZHEE7TR	6.3	150	0.44	230	6.3x5.7
ZH227M6V3HEHTA	CAE227M0JHZHEG7TR	6.3	220	0.36	280	6.3x7.7
ZH337M6V3HFITA	CAE337M0JHZHFF5TR	6.3	330	0.36	280	8x6.5
ZH337M6V3HFKTA	CAE337M0JHZHFJ2TR	6.3	330	0.17	450	8x10.2
ZH477M6V3HFKTA	CAE477M0JHZHFJ2TR	6.3	470	0.17	450	8x10.2
ZH477M6V3HGJTA	CAE477M0JHZHGG7TR	6.3	470	0.17	450	10x7.7
ZH687M6V3HFKTA	CAE687M0JHZHFJ2TR	6.3	680	0.17	450	8x10.2
ZH687M6V3HGJTA	CAE687M0JHZHGG7TR	6.3	680	0.17	450	10x7.7
ZH108M6V3HFKTA	CAE108M0JHZHFJ2TR	6.3	1000	0.17	450	8x10.2
ZH158M6V3HGKTA	CAE158M0JHZHGJ2TR	6.3	1500	0.09	670	10x10.2
ZH338M6V3HPNTA	CAE338M0JHZHI1CTR	6.3	3300	0.07	820	12.5x13.5



**ELECTRICAL CHARACTERISTICS** - Ta = 25°C, FOR DIFFERENT PART CODE

NEXTGEN PART CODE	ORIGINAL PART NUMBER	RATE VOL.	CAPACITOR VALUE	MAX. IMPEDANCE @20 °C 100KHZ	MAX. RIPPLE CURRENT @ 105°C 100KHZ	CASE SIZE ØD X L
		V	µF	mΩ	mA r.m.s	mm
ZH226M010HCHTA	CAE226M1AHZHCE7TR	10	22	1.35	80	4x5.7
ZH336M010HDHTA	CAE336M1AHZHDE7TR	10	33	0.8	150	5x5.7
ZH476M010HEHTA	CAE476M1AHZHEE7TR	10	47	0.44	230	6.3x5.7
ZH107M010HEHTA	CA107M1AHZHEE7TR	10	100	0.44	230	6.3x5.7
ZH157M010HEHTA	CAE157M1AHZHEE7TR	10	150	0.44	230	6.3x5.7
ZH227M010HEJTA	CAE227M1AHZHCE7TR	10	220	0.36	280	6.3x7.7
ZH227M010HFITA	CAE227M1AHZHFF5TR	10	220	0.36	280	8x6.5
ZH337M010HFKTA	CAE337M1AHZHfJ2TR	10	330	0.17	450	8x10.2
ZH337M010HGJTA	CAE337M1AHZHGG7TR	10	330	0.17	450	10x7.7
ZH477M010HFKTA	CAE477M1AHZHfJ2TR	10	470	0.17	450	8x10.2
ZH477M010HGJTA	CAE477M1AHZHGG7TR	10	470	0.17	450	10x7.7
ZH687M010HGKTA	CAE687M1AHZHGJ2TR	10	680	0.09	670	10x10.2
ZH108M010HGKTA	CAE108M1AHZHGJ2TR	10	1000	0.09	670	10x10.2
ZH158M010HPNTA	CAE158M1AHZHI1CTR	10	1500	0.07	820	12.5x13.5

**ELECTRICAL CHARACTERISTICS** - Ta = 25°C, FOR DIFFERENT PART CODE

NEXTGEN PART CODE	ORIGINAL PART NUMBER	RATE VOL.	CAPACITOR VALUE	MAX. IMPEDANCE @20 °C 100KHZ	MAX. RIPPLE CURRENT @ 105°C 100KHZ	CASE SIZE ØD X L
		V	µF	mΩ	mA r.m.s	mm
ZH106M016HCHTA	CAE106M1CHZHCE7TR	16	10	1.35	80	4x5.7
ZH226M016HDHTA	CAE226M1CHZHDE7TR	16	22	0.8	150	5x5.7
ZH336M016HEHTA	CAE336M1CHZHEE7TR	16	33	0.44	230	6.3x5.7
ZH476M016HEHTA	CAE476M1CHZHEE7TR	16	47	0.44	230	6.3x5.7
ZH107M016HEHTA	CAE107M1CHZHEE7TR	16	100	0.44	230	6.3x5.7
ZH157M016HEJTA	CAE157M1CHZHEG7TR	16	150	0.36	280	6.3x7.7
ZH157M016HFITA	CAE157M1CHZHFF5TR	16	150	0.36	280	8x6.5
ZH227M016HEJTA	CAE227M1CHZHEG7TR	16	220	0.36	280	6.3x7.7
ZH337M016HFKTA	CAE337M1CHZHfJ2TR	16	330	0.17	450	8x10.2
ZH337M016HGJTA	CAE337M1CHZHGG7TR	16	330	0.17	450	10x7.7
ZH477M016HFKTA	CAE477M1CHZHfJ27TR	16	470	0.17	450	8x10.2
ZH477M016HGKTA	CAE477M1CHZHGJ2TR	16	470	0.09	670	10x10.2
ZH687M016HGKTA	CAE687M1CHZHGJ2TR	16	680	0.09	670	10x10.2
ZH108M016HPNTA	CAE108M1CHZHI1CTR	16	1000	0.07	820	12.5x13.5
ZH338M016HQOTA	CAE338M1CHZHK1FTR	16	3300	0.054	1260	16x16.5

**ELECTRICAL CHARACTERISTICS** - Ta = 25°C, FOR DIFFERENT PART CODE

NEXTGEN PART CODE	ORIGINAL PART NUMBER	RATE VOL.	CAPACITOR VALUE	MAX. IMPEDANCE @20 °C 100KHZ	MAX. RIPPLE CURRENT @ 105°C 100KHZ	CASE SIZE ØD X L
		V	µF	mΩ	mA r.m.s	mm
ZH106M025HCHTA	CAE106M1EHZHCH7TR	25	10	1.35	80	4x5.7
ZH226M025HDHTA	CAE226M1EHZHDH7TR	25	22	0.8	150	5x5.7
ZH336M025HEHTA	CAE336M1EHZHHEE7TR	25	33	0.44	230	6.3x5.7
ZH476M025HEHTA	CAE476M1EHZHHEE7TR	25	47	0.44	230	6.3x5.7
ZH157M025HEJTA	CAE107M1EHZHHEG7TR	25	100	0.36	280	6.3x7.7
ZH157M025HFITA	CAE107M1EHZHFF5TR	25	100	0.36	280	8x6.5
ZH157M025HFKTA	CAE157M1EHZHFFJ2TR	25	150	0.17	450	8x10.2
ZH227M025HFKTA	CAE227M1EHZHFFJ2TR	25	220	0.17	450	8x10.2
ZH227M025HGJTA	CAE227M1EHZHGG7TR	25	220	0.17	450	10x7.7
ZH337M025HFKTA	CAE337M1EHZHFFJ2TR	25	330	0.17	450	8x10.2
ZH477M025HGKTA	CAE477M1EHZHGGJ2TR	25	470	0.09	670	10x10.2
ZH687M025HPNTA	CAE687M1EHZHI1CTR	25	680	0.07	820	12.5x13.5
ZH108M025HPOTA	CAE108M1EHZHI1FTR	25	1000	0.06	950	12.5x16.5
ZH228M025HQOTA	CAE228M1EHZHK1FTR	25	2200	0.054	1260	16x16.5
ZH338M025HPRTA	CAE338M1EHZHK2ATR	25	3300	0.038	1630	16x21.5

**ELECTRICAL CHARACTERISTICS** - Ta = 25°C, FOR DIFFERENT PART CODE

NEXTGEN PART CODE	ORIGINAL PART NUMBER	RATE VOL.	CAPACITOR VALUE	MAX. IMPEDANCE @20 °C 100KHZ	MAX. RIPPLE CURRENT @ 105°C 100KHZ	CASE SIZE ØD X L
		V	µF	mΩ	mA r.m.s	mm
ZH475M035HCHTA	CAE475M1VHZHCH7TR	35	4.7	1.35	80	4x5.7
ZH106M035HDHTA	CAE106M1VHZHDH7TR	35	10	0.8	150	5x5.7
ZH226M035HEHTA	CAE226M1VHZHEE7TR	35	22	0.44	230	6.3x5.7
ZH336M035HEHTA	CAE336M1VHZHEE7TR	35	33	0.44	230	6.3x5.7
ZH476M035HEHTA	CAE476M1VHZHEE7TR	35	47	0.44	230	6.3x5.7
ZH686M035HFITA	CAE686M1VHZHFF5TR	35	68	0.36	280	8x6.5
ZH107M035HFKTA	CAE107M1VHZHFJ2TR	35	100	0.17	450	8x10.2
ZH157M035HFKTA	CAE157M1VHZHFJ2TR	35	150	0.17	450	8x10.2
ZH157M035HGJTA	CAE157M1VHZHGG7TR	35	150	0.17	450	10x7.7
ZH227M035HGKTA	CAE227M1VHZHGJ2TR	35	220	0.09	670	10x10.2
ZH337M035HGKTA	CAE337M1VHZHGJ2TR	35	330	0.09	670	10x10.2
ZH337M035HGKTA	CAE337M1VHZHI1CTR	35	330	0.07	820	12.5x13.5
ZH477M035HPNTA	CAE477M1VHZHI1CTR	35	470	0.07	820	12.5x13.5
ZH108M035HQOTA	CAE108M1VHZHK1FTR	35	1000	0.054	1260	16x16.5

**ELECTRICAL CHARACTERISTICS** - Ta = 25°C, FOR DIFFERENT PART CODE

NEXTGEN PART CODE	ORIGINAL PART NUMBER	RATE VOL.	CAPACITOR VALUE	MAX. IMPEDANCE @20 °C 100KHZ	MAX. RIPPLE CURRENT @ 105°C 100KHZ	CASE SIZE ØD X L
		V	µF	mΩ	mA r.m.s	mm
ZH105M050HCHTA	CAE105M1HHZHCH7TR	50	1	2.9	60	4x5.7
ZH225M050HCHTA	CAE225M1HHZHCH7TR	50	2.2	2.9	60	4x5.7
ZH335M050HCHTA	CAE335M1HHZHCH7TR	50	3.3	2.9	60	4x5.7
ZH475M050HDHTA	CAE475M1HHZHDE7TR	50	4.7	1.52	85	5x5.7
ZH106M050HEHTA	CAE106M1HHZHHEE7TR	50	10	0.88	165	6.3x5.7
ZH226M050HEHTA	CAE226M1HHZHHEE7TR	50	22	0.88	165	6.3x5.7
ZH336M050HEJTA	CAE336M1HHZHHEG7TR	50	33	0.68	185	6.3x7.7
ZH476M050HEJTA	CAE476M1HHZHHEG7TR	50	47	0.68	185	6.3x7.7
ZH476M050HFITA	CAE476M1HHZHFF5TR	50	47	0.68	185	8x6.5
ZH686M050HFKTA	CAE686M1HHZHFFJ2TR	50	68	0.34	369	8x10.2
ZH107M050HFKTA	CAE107M1HHZHFFJ2TR	50	100	0.34	369	8x10.2
ZH107M050HGKTA	CAE107M1HHZHGGJ2TR	50	100	0.18	553	10x10.2
ZH157M050HGKTA	CAE157M1HHZHGGJ2TR	50	150	0.18	553	10x10.2
ZH227M050HGKTA	CAE227M1HHZHGGJ2TR	50	220	0.18	553	10x10.2
ZH227M050HPNTA	CAE227M1HHZHII1CTR	50	220	0.12	650	12.5x13.5
ZH337M050HPNTA	CAE337M1HHZHII1CTR	50	330	0.12	650	12.5x13.5
ZH108M050HQOTA	CAE108M1HHZHKI1FTR	50	1000	0.073	1000	16x16.5

**ELECTRICAL CHARACTERISTICS** - Ta = 25°C, FOR DIFFERENT PART CODE

NEXTGEN PART CODE	ORIGINAL PART NUMBER	RATE VOL.	CAPACITOR VALUE	MAX. IMPEDANCE @20 °C 100KHZ	MAX. RIPPLE CURRENT @ 105°C 100KHZ	CASE SIZE ØD X L
		V	µF	mΩ	mA r.m.s	mm
ZH475M063HDHTA	CAE475M1JHZHDE7TR	63	4.7	1.9	70	5x5.7
ZH106M063HEHTA	CAE106M1JHZHEE7TR	63	10	1.2	130	6.3x5.7
ZH226M063HEJTA	CAE226M1JHZHEG7TR	63	22	0.9	150	6.3x7.7
ZH336M063HFKTA	CAE336M1JHZHFJ2TR	63	33	0.5	280	8x10.2
ZH476M063HFKTA	CAE476M1JHZHFJ2TR	63	47	0.5	280	8x10.2
ZH107M063HGKTA	CAE107M1JHZHGJ2TR	63	100	0.25	450	10x10.2
ZH157M063HPNTA	CAE157M1JHZHI1CTR	63	150	0.15	700	12.5x13.5
ZH227M060HPNTA	CAE227M1JHZHI1CTR	63	220	0.15	700	12.5x13.5
ZH226M080HFKTA	CAE226M1KHZHFJ2TR	80	22	1.3	130	8x10.2
ZH336M080HFKTA	CAE336M1KHZHFJ2TR	80	33	1.3	130	8x10.2
ZH476M080HGKTA	CAE476M1KHZHGJ2TR	80	47	0.7	200	10x10.2
ZH107M080HGKTA	CAE107M1KHZHGJ2TR	80	100	0.7	200	10x10.2
ZH157M080HPNTA	CAE157M1KHZHI1CTR	80	150	0.32	450	12.5x13.5
ZH226M100HFKTA	CAE226M2AHZHFJ2TR	100	22	1.3	130	8x10.2
ZH336M100HGKTA	CAE336M2AHZHGJ2TR	100	33	0.7	200	10x10.2
ZH476M100HGKTA	CAE476M2AHZHGJ2TR	100	47	0.7	200	10x10.2
ZH107M100HPNTA	CAE226M2AHZHFJ2TR	100	22	0.32	450	12.5x13.5

Remark

- 1) Specification are subject to change without notice should a safety or technical concern arise regarding the product, please be sure to contact our sales offices.
- 2) The sizes in the above table are all standard specifications. If you need custom parameters , please contact us.

## CHARACTERISTICS

Standard Atmospheric Conditions

The standard range of atmospheric conditions for making measurements/test as follows:

Ambient temperature: 15°C to 35°C

Relative humidity: 45% to 85%

Air Pressure: 86kPa to 106kPa

If there is any doubt about the results, measurement shall be made within the following conditions:

Ambient temperature: 20°C ± 2°C

Relative humidity: 60% to 70%

Air Pressure: 86kPa to 106kPa

As to the detailed information, please refer to following Table

Operating Temperature Range

The ambient temperature range at which the capacitor can be operated continuously at rated voltage is

-55°C to 105°C.

As to the detailed information, please refer to the mentioned table next pages.

ITEM	PERFORMANCE																				
Nominal Capacitance (Tolerance)	<p>&lt;Condition&gt;            Measuring Frequency : 120Hz ± 12Hz            Measuring Voltage : Not more than 0.5V            Measuring Temperature : 20 ± 2°C</p> <p>&lt;Criteria&gt;            Shall be within the specified capacitance tolerance</p>																				
Leakage Current	<p>&lt;Condition&gt;            After DC Voltage is applied to capacitors through the series protective resistor (1kΩ ± 10Ω) so that terminal voltage may reach the reacted use voltage. The leakage current when measured in 2 minutes shall not exceed the values of the following equation.</p> <p>&lt;Criteria&gt;  <math>I (\mu A) \leq 0.01 CV</math> or <math>3 (\mu A)</math>, Whichever is greater            I: Leakage Current (μA)            C: Capacitance (μF)            V: Rated Working Voltage (V)</p>																				
tan δ	<p>&lt;Condition&gt;            See Normal Capacitance, for measuring frequency, voltage and temperature.</p> <p>&lt;Criteria&gt;            The tangent of the loss angle (tan δ) of the capacitors shall refer to the following table. Measurements shall be made under the same conditions as those given for the measurement of the capacitance.</p> <table border="1" data-bbox="402 1508 1333 1612"> <tr> <td>W.V.</td> <td>6.3</td> <td>10</td> <td>16</td> <td>25</td> <td>35</td> <td>50</td> <td>63/80/100</td> </tr> <tr> <td>tan δ</td> <td>0.3</td> <td>0.26</td> <td>0.22</td> <td>0.16</td> <td>0.13</td> <td>0.1</td> <td>0.08</td> </tr> </table>	W.V.	6.3	10	16	25	35	50	63/80/100	tan δ	0.3	0.26	0.22	0.16	0.13	0.1	0.08				
W.V.	6.3	10	16	25	35	50	63/80/100														
tan δ	0.3	0.26	0.22	0.16	0.13	0.1	0.08														
Rated Working Voltage (WV) Surge Voltage (SV)	<table border="1" data-bbox="402 1686 1333 1852"> <tr> <td>W.V. (V.DC)</td> <td>6.3</td> <td>10</td> <td>16</td> <td>25</td> <td>35</td> <td>50</td> <td>63</td> <td>80</td> <td>100</td> </tr> <tr> <td>S.V. (V.DC.)</td> <td>7.2</td> <td>11.5</td> <td>18.4</td> <td>28.8</td> <td>40.2</td> <td>57.5</td> <td>72.5</td> <td>92</td> <td>115</td> </tr> </table>	W.V. (V.DC)	6.3	10	16	25	35	50	63	80	100	S.V. (V.DC.)	7.2	11.5	18.4	28.8	40.2	57.5	72.5	92	115
W.V. (V.DC)	6.3	10	16	25	35	50	63	80	100												
S.V. (V.DC.)	7.2	11.5	18.4	28.8	40.2	57.5	72.5	92	115												

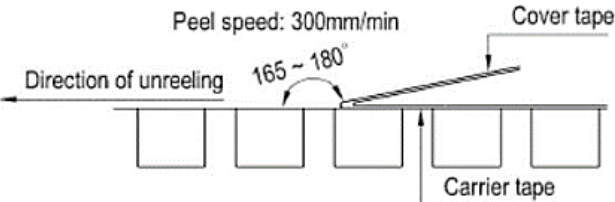

ITEM	PERFORMANCE																																										
Temperature Characteristic IEC-60384-4 4.12	<p>&lt;Condition&gt;</p> <table border="1" data-bbox="425 389 1332 692"> <thead> <tr> <th>Step.</th> <th>Testing Temperature(°C)</th> <th>Time</th> </tr> </thead> <tbody> <tr> <td>1</td> <td>20±2</td> <td>Time to reach thermal equilibrium</td> </tr> <tr> <td>2</td> <td>-55(-25) ±3</td> <td>Time to reach thermal equilibrium</td> </tr> <tr> <td>3</td> <td>20±2</td> <td>Time to reach thermal equilibrium</td> </tr> <tr> <td>4.</td> <td>105±2</td> <td>Time to reach thermal equilibrium</td> </tr> <tr> <td>5</td> <td>20±2</td> <td>Time to reach thermal equilibrium</td> </tr> </tbody> </table> <p>&lt;Criteria&gt;</p> <p>a. At +105°C, capacitance shall be within ±20% of their origin at +20°C, measured capacitance, tan δ shall be within limit of 4.3. The leakage current value at +105°C shall not more than 8 times the specified value.</p> <p>b. At step 5, tan δ shall be within the limit of 4.3. The leakage current value shall not more than the specified value.</p> <p>c. At -55°C (-25°C), impedance (Z) ratio shall not exceed the value of the following table.</p> <table border="1" data-bbox="401 1100 1319 1353"> <thead> <tr> <th>Rated Voltage (V)</th> <th>6.3</th> <th>10</th> <th>16</th> <th>25</th> <th>35/50/63</th> <th>80</th> <th>100</th> </tr> </thead> <tbody> <tr> <td>Z-25°C/Z+20°C (120Hz)</td> <td>4</td> <td>3</td> <td>2</td> <td>2</td> <td>2</td> <td>2</td> <td>2</td> </tr> <tr> <td>Z-55°C/Z+20°C (120Hz)</td> <td>12</td> <td>8</td> <td>4</td> <td>4</td> <td>3</td> <td>3</td> <td>3</td> </tr> </tbody> </table> <p>d. Capacitance tan δ and impedance shall be measured at 120Hz</p>	Step.	Testing Temperature(°C)	Time	1	20±2	Time to reach thermal equilibrium	2	-55(-25) ±3	Time to reach thermal equilibrium	3	20±2	Time to reach thermal equilibrium	4.	105±2	Time to reach thermal equilibrium	5	20±2	Time to reach thermal equilibrium	Rated Voltage (V)	6.3	10	16	25	35/50/63	80	100	Z-25°C/Z+20°C (120Hz)	4	3	2	2	2	2	2	Z-55°C/Z+20°C (120Hz)	12	8	4	4	3	3	3
Step.	Testing Temperature(°C)	Time																																									
1	20±2	Time to reach thermal equilibrium																																									
2	-55(-25) ±3	Time to reach thermal equilibrium																																									
3	20±2	Time to reach thermal equilibrium																																									
4.	105±2	Time to reach thermal equilibrium																																									
5	20±2	Time to reach thermal equilibrium																																									
Rated Voltage (V)	6.3	10	16	25	35/50/63	80	100																																				
Z-25°C/Z+20°C (120Hz)	4	3	2	2	2	2	2																																				
Z-55°C/Z+20°C (120Hz)	12	8	4	4	3	3	3																																				
Sealing Tape Reel Strength	<p>&lt;Condition&gt;</p> <p>Peel angle: 165 to 180°C referred to the surface on which the tape is glued.</p> <p>Peel speed: 300mm per minutes</p> <p>The peel strength must be 0.1 ~ 0.7N under these conditions.</p> 																																										

ITEM	PERFORMANCE										
<p>Load Life Test IEC-60384- 4 4.13</p>	<p>&lt;Condition&gt; The capacitor is stored at a temperature of 105 ° C ± 2 with rated voltage applied continuously for 2000 hours for Ø D≤6.3mm &amp; 8x6.5L &amp; 10x7.7L, 5000 hours for Ø D ≥ 8mm, Then the product should be tested after 16 hours recovering time at atmospheric conditions. The result should meet the following table: &lt;Criteria&gt; The characteristic shall meet the following requirements.</p> <table border="1" data-bbox="444 629 1300 944"> <tr> <td>Capacitance Change</td> <td>± 30% of initial measured value.</td> </tr> <tr> <td>tan δ</td> <td>300% or less of the specified value</td> </tr> <tr> <td>Leakage current</td> <td>Not more than the specified value.</td> </tr> <tr> <td>Appearance</td> <td>No leakage of electrolyte or swelling of the case. All markings shall be legible</td> </tr> <tr> <td>Inner construction</td> <td>No corrosion of tab terminals or electrodes</td> </tr> </table> <p>Remarks: Prior to the measurement of the leakage current, the D.C. rated voltage shall be applied across the capacitor and its protective resistance (1kΩ) for 30 mines after which it shall be discharged.</p>	Capacitance Change	± 30% of initial measured value.	tan δ	300% or less of the specified value	Leakage current	Not more than the specified value.	Appearance	No leakage of electrolyte or swelling of the case. All markings shall be legible	Inner construction	No corrosion of tab terminals or electrodes
Capacitance Change	± 30% of initial measured value.										
tan δ	300% or less of the specified value										
Leakage current	Not more than the specified value.										
Appearance	No leakage of electrolyte or swelling of the case. All markings shall be legible										
Inner construction	No corrosion of tab terminals or electrodes										
<p>Shelf Life Test IEC-60384- 4 4.17</p>	<p>&lt;Condition&gt; The capacitors are then stored with no voltage applied at a temperature of 105 ±2°C for 1000+48/0 hours. Following this period the capacitors shall be removed from the test chamber and be allowed to stabilized at room temperature for 4~8 hours. Next they shall be connected to a series limiting resistor(1k±100Ω) with D.C. rated voltage applied for 30min. After which the capacitors shall be discharged, and then, tested the characteristics. &lt;Criteria&gt; The characteristic shall meet the following requirements.</p> <table border="1" data-bbox="444 1493 1300 1808"> <tr> <td>Capacitance Change</td> <td>± 30% of initial measured value.</td> </tr> <tr> <td>tan δ</td> <td>300% or less of the specified value</td> </tr> <tr> <td>Leakage current</td> <td>Not more than 200% of the specified value</td> </tr> <tr> <td>Appearance</td> <td>No leakage of electrolyte or swelling of the case. All markings shall be legible</td> </tr> <tr> <td>Inner construction</td> <td>No corrosion of tab terminals or electrodes</td> </tr> </table> <p>Remark: If the capacitors are stored more than 1 year, the leakage current may increase. Please apply voltage through about 1 KΩ resistor, if necessary.</p>	Capacitance Change	± 30% of initial measured value.	tan δ	300% or less of the specified value	Leakage current	Not more than 200% of the specified value	Appearance	No leakage of electrolyte or swelling of the case. All markings shall be legible	Inner construction	No corrosion of tab terminals or electrodes
Capacitance Change	± 30% of initial measured value.										
tan δ	300% or less of the specified value										
Leakage current	Not more than 200% of the specified value										
Appearance	No leakage of electrolyte or swelling of the case. All markings shall be legible										
Inner construction	No corrosion of tab terminals or electrodes										

ITEM	PERFORMANCE								
<p>Surge Test IEC-60384- 4 4.9</p>	<p>&lt;Condition&gt; Test temperature:15~35°C Series resistor: <math>R = \frac{100 \pm 50}{C}</math> R: protective resistor (KΩ) C: nominal capacitance (μF) Test voltage: Surge voltage item 4.4 No. of cycles: 1000cycles Each cycles lasts for 6 ± 0.5min "ON" for 30 ± 5 s "OFF" for 5 ± 0.5min.</p> <table border="1" data-bbox="402 665 1283 893"> <tr> <td>Leakage current</td> <td>Not more than the specified value</td> </tr> <tr> <td>Capacitance Change</td> <td>Within ± 15% of initial value.</td> </tr> <tr> <td>tan δ</td> <td>Not more than the specified value.</td> </tr> <tr> <td>Appearance</td> <td>There shall be no leakage of electrolyte.</td> </tr> </table> <p>Attention: This test simulates over voltage at abnormal situation, and not be hypothesizing that over voltage is always applied.</p>	Leakage current	Not more than the specified value	Capacitance Change	Within ± 15% of initial value.	tan δ	Not more than the specified value.	Appearance	There shall be no leakage of electrolyte.
Leakage current	Not more than the specified value								
Capacitance Change	Within ± 15% of initial value.								
tan δ	Not more than the specified value.								
Appearance	There shall be no leakage of electrolyte.								
<p>Vibration Test IEC-60384- 4 4.8</p>	<p>&lt;Condition&gt; Fix it at the point 4 mm or less from body. For ones of 12.5 mm or more in diameter or 25 mm or Capacitance; Direction and during of vibration:3 orthogonal directions mutually each for 2 hours(total of 6 hours) Vibration frequency range : 10Hz ~ 55Hz Peak to peak amplitude : 1.5mm Sweep rate : 10Hz ~ 55Hz ~ 10Hz in about 1 minute &lt;Criteria&gt; The characteristic shall meet the following requirements.</p> <table border="1" data-bbox="402 1504 1283 1732"> <tr> <td>Leakage current</td> <td>Not more than the specified value</td> </tr> <tr> <td>Capacitance Change</td> <td>Within ± 10% of initial value.</td> </tr> <tr> <td>tan δ</td> <td>Not more than the specified value.</td> </tr> <tr> <td>Appearance</td> <td>There shall be no leakage of electrolyte.</td> </tr> </table>	Leakage current	Not more than the specified value	Capacitance Change	Within ± 10% of initial value.	tan δ	Not more than the specified value.	Appearance	There shall be no leakage of electrolyte.
Leakage current	Not more than the specified value								
Capacitance Change	Within ± 10% of initial value.								
tan δ	Not more than the specified value.								
Appearance	There shall be no leakage of electrolyte.								

ITEM	PERFORMANCE								
<p>Solderability Test IEC-60384-4-4.6</p>	<p>&lt;Condition&gt; The capacitor shall be tested under the following conditions: Soldering temperature: 245°C ± 3°C Dipping depth: 2mm Dipping speed: 25 ± 2.5mm/s Dipping time: 3 ± 0.5s &lt;Criteria&gt;</p> <table border="1" data-bbox="396 679 1253 762"> <tr> <td>Coating quality</td> <td>A minimum of 95% of the surface being immersed</td> </tr> </table>	Coating quality	A minimum of 95% of the surface being immersed						
Coating quality	A minimum of 95% of the surface being immersed								
<p>Resistance To Solder Heat Test</p>	<p>&lt;Condition&gt; After reflow soldering (item 4.18) The capacitor shall be left at room temperature for before measurement. &lt;Criteria&gt; The characteristic shall meet the following requirements.</p> <table border="1" data-bbox="396 1081 1253 1286"> <tr> <td>Leakage current</td> <td>Not more than the specified value</td> </tr> <tr> <td>Capacitance Change</td> <td>Within ± 10% of initial value.</td> </tr> <tr> <td>tan δ</td> <td>Not more than the specified value.</td> </tr> <tr> <td>Appearance</td> <td>There shall be no leakage of electrolyte.</td> </tr> </table>	Leakage current	Not more than the specified value	Capacitance Change	Within ± 10% of initial value.	tan δ	Not more than the specified value.	Appearance	There shall be no leakage of electrolyte.
Leakage current	Not more than the specified value								
Capacitance Change	Within ± 10% of initial value.								
tan δ	Not more than the specified value.								
Appearance	There shall be no leakage of electrolyte.								
<p>Damp Heat Test IEC60384-4-4.12</p>	<p>&lt;Condition&gt; Humidity Test: According to IEC60384-4 No.4.12 methods, capacitor shall be exposed for 1000±8 hours in an atmosphere of 90~95%R.H. at 60±3°C, the characteristic change shall meet the following requirement. &lt;Criteria&gt;</p> <table border="1" data-bbox="396 1665 1253 1871"> <tr> <td>Leakage current</td> <td>Not more than the specified value</td> </tr> <tr> <td>Capacitance Change</td> <td>Within ± 20% of initial value.</td> </tr> <tr> <td>tan δ</td> <td>Not more than 120% of the specified value.</td> </tr> <tr> <td>Appearance</td> <td>There shall be no leakage of electrolyte.</td> </tr> </table>	Leakage current	Not more than the specified value	Capacitance Change	Within ± 20% of initial value.	tan δ	Not more than 120% of the specified value.	Appearance	There shall be no leakage of electrolyte.
Leakage current	Not more than the specified value								
Capacitance Change	Within ± 20% of initial value.								
tan δ	Not more than 120% of the specified value.								
Appearance	There shall be no leakage of electrolyte.								

ITEM	PERFORMANCE																										
<p>Change Of Temperature Test IEC-60384-4 4.7</p>	<p>&lt;Condition&gt; Temperature cycle: According to IEC60384-4 No.4.7 methods, capacitor shall be placed in an oven, the condition according as below</p> <table border="1" data-bbox="404 466 1302 768"> <thead> <tr> <th>No.</th> <th>Temperature</th> <th>Time</th> </tr> </thead> <tbody> <tr> <td>1</td> <td>+25°C</td> <td>≤3 Minutes</td> </tr> <tr> <td>2</td> <td>-55°C</td> <td>30±2 Minutes</td> </tr> <tr> <td>3</td> <td>+25°C</td> <td>≤3 Minutes</td> </tr> <tr> <td>4</td> <td>+105°C</td> <td>30±2 Minutes</td> </tr> <tr> <td>5</td> <td>+25°C</td> <td>≤3 Minutes</td> </tr> </tbody> </table> <p style="text-align: center;">1 to 5 = 1 cycle, Total 5 cycles</p> <p>and then the capacitor shall be subjected to standard atmospheric conditions for 4 hours, after which measurements shall be made.</p> <p>&lt;Criteria&gt; The characteristic shall meet the following requirements.</p> <table border="1" data-bbox="404 1052 1302 1257"> <tbody> <tr> <td>Capacitance Change</td> <td>Within ±10% of initial value.</td> </tr> <tr> <td>tan δ</td> <td>Not more than the specified value.</td> </tr> <tr> <td>Leakage current</td> <td>Not more than the specified value.</td> </tr> <tr> <td>Appearance</td> <td>No broken and undamaged.</td> </tr> </tbody> </table>	No.	Temperature	Time	1	+25°C	≤3 Minutes	2	-55°C	30±2 Minutes	3	+25°C	≤3 Minutes	4	+105°C	30±2 Minutes	5	+25°C	≤3 Minutes	Capacitance Change	Within ±10% of initial value.	tan δ	Not more than the specified value.	Leakage current	Not more than the specified value.	Appearance	No broken and undamaged.
No.	Temperature	Time																									
1	+25°C	≤3 Minutes																									
2	-55°C	30±2 Minutes																									
3	+25°C	≤3 Minutes																									
4	+105°C	30±2 Minutes																									
5	+25°C	≤3 Minutes																									
Capacitance Change	Within ±10% of initial value.																										
tan δ	Not more than the specified value.																										
Leakage current	Not more than the specified value.																										
Appearance	No broken and undamaged.																										
<p>Low Temperature Test</p>	<p>&lt;Condition&gt; Capacitors are placed at -55 ± 3°C for 96 ± 4 hours. And then the capacitor shall be subjected to standard atmospheric conditions for 4 hours, after which measurements shall be made.</p> <p>&lt;Criteria&gt;</p> <table border="1" data-bbox="404 1589 1282 1792"> <tbody> <tr> <td>Leakage current</td> <td>Not more than the specified value</td> </tr> <tr> <td>Capacitance Change</td> <td>Within ±10% of initial value.</td> </tr> <tr> <td>tan δ</td> <td>Not more than the specified value.</td> </tr> <tr> <td>Appearance</td> <td>No broken and undamaged</td> </tr> </tbody> </table>	Leakage current	Not more than the specified value	Capacitance Change	Within ±10% of initial value.	tan δ	Not more than the specified value.	Appearance	No broken and undamaged																		
Leakage current	Not more than the specified value																										
Capacitance Change	Within ±10% of initial value.																										
tan δ	Not more than the specified value.																										
Appearance	No broken and undamaged																										

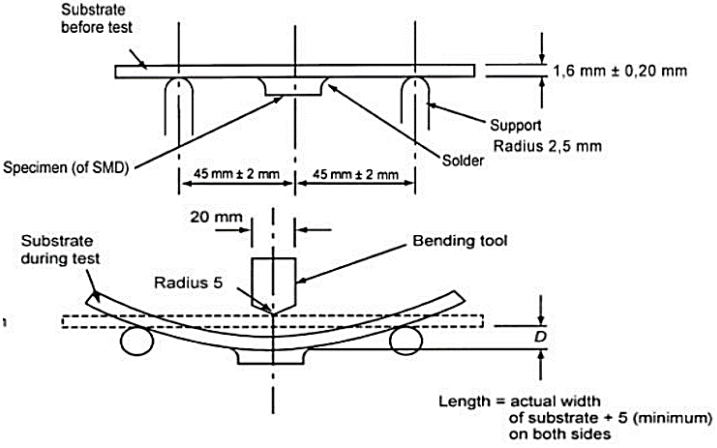
ITEM	PERFORMANCE				
<p>Vent Test IEC-60384-4 4.16</p>	<p>&lt;Condition&gt;</p> <p>The following test only apply to those products with vent products at diameter <math>\geq \varnothing 8</math> with vent.</p> <p>D.C. test</p> <p>The capacitor is connected with its polarity reversed to a DC power source. Then a current selected from following table is applied.</p> <table border="1" data-bbox="454 634 1168 737"> <thead> <tr> <th>Diameter (mm)</th> <th>DC Current (A)</th> </tr> </thead> <tbody> <tr> <td>22.4 or less</td> <td>1</td> </tr> </tbody> </table> <p>&lt;Criteria&gt;</p> <p>No emission of gas after 30 minutes of the voltage application also meets the specification. The vent shall operate with no dangerous conditions such as flames or dispersion of pieces of the capacitor and/or case.</p>	Diameter (mm)	DC Current (A)	22.4 or less	1
Diameter (mm)	DC Current (A)				
22.4 or less	1				
<p>Mechanical Characteristics Test</p>	<p>&lt;Condition&gt;</p> <p>Bending Test: Apply pressure in the direction of the arrow at a rate of about 0.5 mm/s until bent width reaches 2 mm and hold for 60s. The board shall be the test board "B" as specified in JIS C 0051: 2002. If the land area differs, it shall be specified clearly in the next item.</p>  <p>&lt;Criteria&gt;</p> <p>Without mechanical damage such as breaks. Electrical characteristics shall be satisfied.</p> <p>If there are electrodes on both surfaces, above requirements shall be satisfied on whichever surface it may be fixated on.</p>				

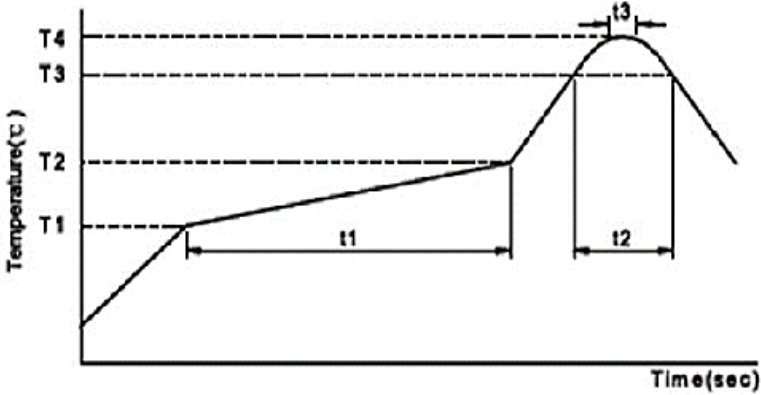
ITEM	PERFORMANCE								
Reflow Soldering  Temperature Profile	<table border="1" data-bbox="408 323 1296 478"> <thead> <tr> <th>Welding Method</th> <th>Reflow Soldering</th> <th>Soldering Iron</th> <th>Wave Soldering</th> </tr> </thead> <tbody> <tr> <td>The feasibility of</td> <td>Feasible</td> <td>Feasible</td> <td>Is not workable</td> </tr> </tbody> </table> <p data-bbox="394 513 948 544">Conditions for the use of lead-free reflow soldering.</p>  <p data-bbox="394 990 666 1021">1) Methods the following</p> <p data-bbox="394 1038 1319 1307">Reflow soldering: please follow the temperature condition during welding. If high temperature is used, please measure and inform the capacitor temperature and reflow soldering condition. The product size is larger and its rising temperature is slower. It is not necessary to adjust the temperature of the reflow solder in accordance with the size of the product. For example, the products of 4 and 10 will be installed in the PCB over tin furnace.</p> <p data-bbox="394 1328 1258 1359">2) Precautions for soldering tin: Related factors of reflow soldering temperature:</p> <p data-bbox="394 1375 1162 1406">Product size: The product size is larger and its temperature rises slowly.</p> <p data-bbox="394 1423 1319 1454">Product installation position: The temperature of PCB center is lower than that of PCB</p> <p data-bbox="394 1471 601 1502">3) Reflow soldering</p> <p data-bbox="394 1518 822 1549">If possible, avoid reflow soldering twice.</p> <p data-bbox="394 1566 1258 1643">If repeated reflux is unavoidable, measure and inform the first and second reflux temperature, and the time of reflow soldering</p> <p data-bbox="394 1659 858 1690">4) Please do not 3 times of reflow soldering</p> <p data-bbox="394 1707 1115 1738">Please follow the following conditions when soldering tin soldering:</p> <p data-bbox="394 1754 936 1786">Soldering iron maximum temperature: <math>350 \pm 5^{\circ}\text{C}</math>;</p> <p data-bbox="394 1802 648 1833">Welding time: 3+1/-0S</p>	Welding Method	Reflow Soldering	Soldering Iron	Wave Soldering	The feasibility of	Feasible	Feasible	Is not workable
Welding Method	Reflow Soldering	Soldering Iron	Wave Soldering						
The feasibility of	Feasible	Feasible	Is not workable						

ITEM	PERFORMANCE																																																																																		
Reflow Soldering  Temperature Profile	<p>Test Method And Peak Temperature Permissible Range</p> <table border="1" data-bbox="425 381 1276 779"> <thead> <tr> <th colspan="2">Products category</th> <th colspan="6">SMD aluminum electrolytic capacitor</th> </tr> </thead> <tbody> <tr> <td colspan="2">voltage ( V )</td> <td>4~50</td> <td>4~50</td> <td>≥63</td> <td>4~100</td> <td colspan="2">≥160</td> </tr> <tr> <td colspan="2">Product size</td> <td>Φ4~6.3 3×4.5 L</td> <td>Φ4~6.3</td> <td>Φ4~6.3</td> <td>Φ8~18</td> <td colspan="2">≥Φ12.5</td> </tr> <tr> <td rowspan="2">Preheating</td> <td>TEM ( T<sub>1</sub>~T<sub>2</sub> , °C )</td> <td colspan="6">150~180</td> </tr> <tr> <td>Time ( t<sub>1</sub> ) Max, S</td> <td>120</td> <td colspan="5">180</td> </tr> <tr> <td rowspan="2">The duration of the</td> <td>TEM ( T<sub>3</sub> , °C )</td> <td>230</td> <td>217</td> <td>230</td> <td>217</td> <td>217</td> <td>230</td> <td>217</td> </tr> <tr> <td>Time ( t<sub>2</sub> ) Max, S</td> <td>30</td> <td>90</td> <td>60</td> <td>60</td> <td>60</td> <td>40</td> <td>60</td> </tr> <tr> <td rowspan="2">The highest temperature</td> <td>TEM ( T<sub>4</sub> , °C )</td> <td>250</td> <td colspan="2">260</td> <td>250</td> <td colspan="2">250</td> <td>240</td> </tr> <tr> <td>Time ( t<sub>3</sub> ) Max, S</td> <td colspan="7">5</td> </tr> <tr> <td colspan="2">Return the number</td> <td>1</td> <td colspan="6">≤2</td> </tr> </tbody> </table> <ul style="list-style-type: none"> <li>• Please contact us if the conditions of use are higher than those listed above.</li> <li>• When performing second reflow soldering, please make sure the temperature of capacitor has cooled to 5 ~ 35 °C.</li> <li>• If the reflow condition is based on IPC/JEDEC(J-STD-020), please contact us.</li> </ul> <p>OP-CAP Precautions:</p> <ul style="list-style-type: none"> <li>• Reflow soldering will reduce the rated electrostatic capacity of the product, and it should be confirmed whether reflow soldering condition meets the specification of recommended reflow soldering.</li> <li>• Although the actual reflow condition change is still based on the reflow soldering method, please note that the highest temperature and the electrode terminal at the bottom of the aluminum shell must not exceed the maximum temperature.</li> <li>• OP-APproductsduringtheprocessofreflowheatingtemperatureshouldincrease to more than 200 °C</li> <li>• If the reflow condition temperature or duration is greater than the above table, the OP-CAP product will be damaged. The electrostatic capacity of the product is reduced by about 50%, the leakage current is large (up to m A), and the outside of the capacitor is damaged.</li> </ul> <p>Recommended Land Size (see page 5)</p>	Products category		SMD aluminum electrolytic capacitor						voltage ( V )		4~50	4~50	≥63	4~100	≥160		Product size		Φ4~6.3 3×4.5 L	Φ4~6.3	Φ4~6.3	Φ8~18	≥Φ12.5		Preheating	TEM ( T <sub>1</sub> ~T <sub>2</sub> , °C )	150~180						Time ( t <sub>1</sub> ) Max, S	120	180					The duration of the	TEM ( T <sub>3</sub> , °C )	230	217	230	217	217	230	217	Time ( t <sub>2</sub> ) Max, S	30	90	60	60	60	40	60	The highest temperature	TEM ( T <sub>4</sub> , °C )	250	260		250	250		240	Time ( t <sub>3</sub> ) Max, S	5							Return the number		1	≤2					
Products category		SMD aluminum electrolytic capacitor																																																																																	
voltage ( V )		4~50	4~50	≥63	4~100	≥160																																																																													
Product size		Φ4~6.3 3×4.5 L	Φ4~6.3	Φ4~6.3	Φ8~18	≥Φ12.5																																																																													
Preheating	TEM ( T <sub>1</sub> ~T <sub>2</sub> , °C )	150~180																																																																																	
	Time ( t <sub>1</sub> ) Max, S	120	180																																																																																
The duration of the	TEM ( T <sub>3</sub> , °C )	230	217	230	217	217	230	217																																																																											
	Time ( t <sub>2</sub> ) Max, S	30	90	60	60	60	40	60																																																																											
The highest temperature	TEM ( T <sub>4</sub> , °C )	250	260		250	250		240																																																																											
	Time ( t <sub>3</sub> ) Max, S	5																																																																																	
Return the number		1	≤2																																																																																



**TAPE** (Unit: mm), Applicable standard JIS C0806 and IEC 60286.

Fig. 1 ( $\varnothing 4 \sim \varnothing 10$ )

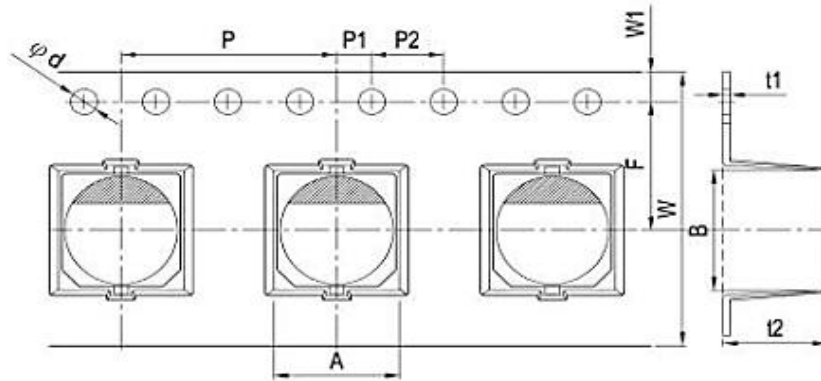

SIZE	W	P	F	A0	B0	t2	$\varnothing d$	P1	P2	t1	W1
$\varnothing 4 \times 5.7$ & 5.8	12	8	5.5	4.7	4.7	5.8	1.5	2.0	4.0	0.4	1.75
$\varnothing 5 \times 5.7$ & 5.8	12	12	5.5	6.0	6.0	5.8	1.5	2.0	4.0	0.4	1.75
$\varnothing 6.3 \times 5.7$ & 5.8	16	12	7.5	7.0	7.0	5.8	1.5	2.0	4.0	0.4	1.75
$\varnothing 6.3 \times 7.7$	16	12	7.5	7.0	7.0	8.3	1.5	2.0	4.0	0.4	1.75
$\varnothing 6.3 \times 10.2$	16	12	7.5	7.0	7.0	11.0	1.5	2.0	4.0	0.4	1.75
$\varnothing 8 \times 6.5$	16	12	7.5	8.7	8.7	6.8	1.5	2.0	4.0	0.4	1.75
$\varnothing 8 \times 10.2$	24	16	11.5	8.7	8.7	11.0	1.5	2.0	4.0	0.4	1.75
$\varnothing 8 \times 12.5$	24	16	11.5	8.7	8.7	13.0	1.5	2.0	4.0	0.4	1.75
$\varnothing 10 \times 10.2$	24	16	11.5	10.7	10.7	11.0	1.5	2.0	4.0	0.4	1.75
$\varnothing 10 \times 12.5$	24	16	11.5	10.7	10.7	13.0	1.5	2.0	4.0	0.4	1.75
$\varnothing 10 \times 13.5$	24	16	11.5	10.7	10.7	13.0	1.5	2.0	4.0	0.4	1.75

**TAPE** (Unit: mm), Applicable standard JIS C0806 and IEC 60286.

Fig. 2 (Ø12.5 ~ Ø18)

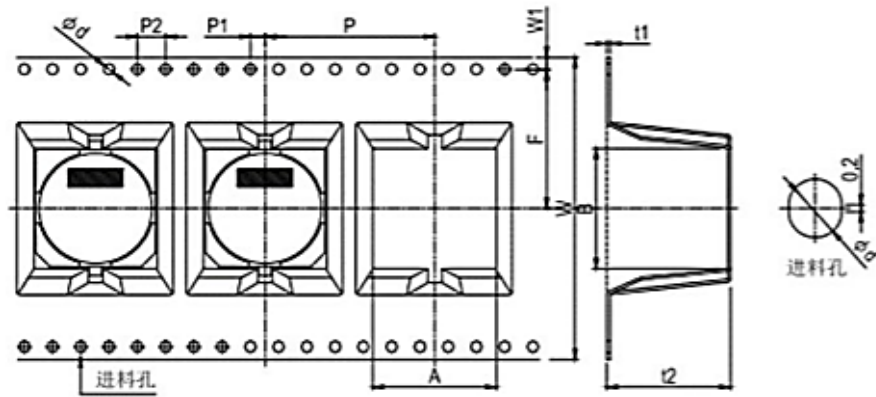

SIZE	W	P	F	A	B	t2	Ød	P1	P2	t1	W1
Ø12x13.5	32	24	14.2	13.4	13.4	14.5	1.5	2	4	0.5	1.75
Ø12.5x16	32	24	14.2	13.4	13.4	17	1.5	2	4	0.5	1.75
Ø16x16.5	44	28	20.2	17.5	17.5	17.5	1.5	2	4	0.5	1.75
Ø16x21.5	44	28	20.2	17.5	17.5	22.5	1.5	2	4	0.5	1.75
Ø18x16.5	44	32	20.2	19.5	19.5	17.5	1.5	2	4	0.5	1.75

**REEL** (Unit: mm), Applicable standard JIS C0806 and IEC 60286.

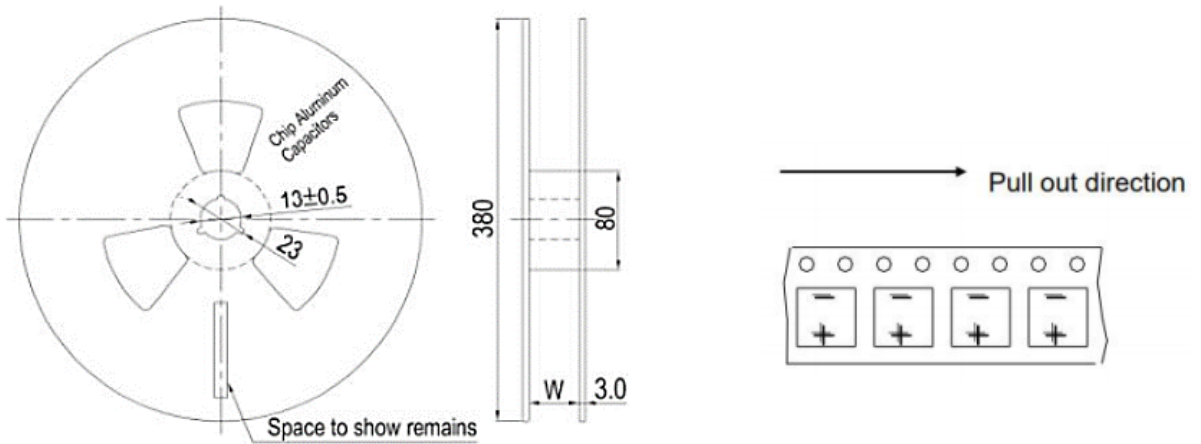

CASE SIZE	Ø4	Ø5	Ø6.3	Ø8X6.5	Ø8X10.2/10.5	Ø10	Ø12.5	Ø16.0
W (mm)	14	14	18	18	26	26	34	46
Qty/Reel (pcs)	2000	1000	1000	1000	500	500	200	200

**PACKING METHOD**

- Polarity: Anode on the opposite side of the feed hole
- The leader length of the tape shall not be less than 400mm including 10 or more embossed sections in which no parts are contained.
- The winding core is provided with an over 40mm long empty section

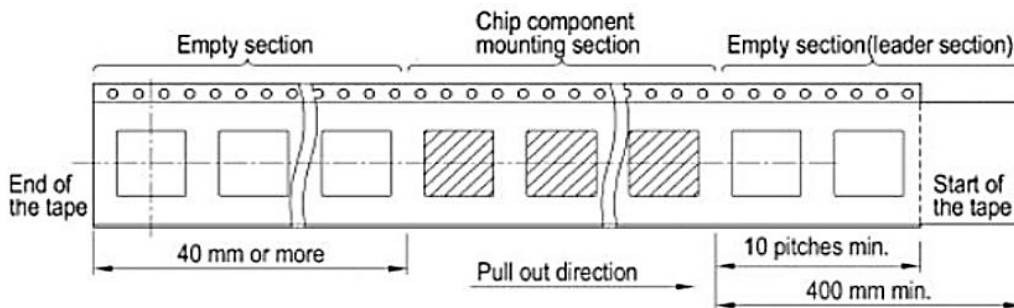

## APPLICATION GUIDELINE

### CIRCUIT DESIGN

1) Please make sure the environmental and mounting conditions to which the capacitor will be exposed are within the conditions specified in catalogue.

2) Operating temperature and applied ripple shall be within specification.

3) Appropriate capacitors which comply with the life requirement of the products should be selected when designing the circuit.

4) Aluminum electrolytic capacitors are polar. Make sure that no reverse voltage or AC voltage is applied to the capacitors. Please use bi-polar capacitors for a circuit that can possibly see reversed polarity.

Note: Even bi-polar capacitors cannot be used for AC voltage application.

5) Do not use aluminum electrolytic capacitors in a circuit that requires rapid and very frequent charge/ discharge. In this type of circuit, it is necessary to use a special design capacitor with extended life characteristics.

6) Do not apply excess voltage.

(1) Please pay attention to that the peak voltage, which is DC voltage overlapped by ripple current, will not exceed the rated voltage.

(2) In the case where more than 2 aluminum electrolytic capacitors are used in series, please make sure that applied voltage will be lower than rated voltage and the voltage will be applied to each capacitor equally by using a balancing resistor in parallel with the capacitor.

7) Aluminum electrolytic capacitors shall not be used under the following environmental conditions:

(1) (a) Capacitors will be exposed to water (including condensation), brine or oil. (b) Ambient conditions that include toxic gases such as hydrogen sulfide, sulfuric acid, nitrous acid, chlorine, bromine, methyl bromide, ammonium, etc. (c) Ambient conditions that expose the capacitor to ozone, ultraviolet ray and radiation.

(2) Severe vibration and physical shock conditions that exceed specification.

Vibration test condition: 10-55-10Hz

Vibration frequency range : 10~55~10hz

Sweep rate : 10~55~10Hz/minute

Sweep method : logarithmic

Amplitude or acceleration : 1.5mm (max. Acceleration is 10G)

Direction of vibration : X, Y, Z direction

Testing time: 2 hours per each direction

Shock is not applicable normally.

If a particular condition is required, please contact our sales team.

8) The main chemical solution of the electrolyte and the separator paper used in the capacitors are combustible.

The electrolyte is conductive. When it comes in contact with the PC board, there is a possibility of pattern corrosion or short circuit between the circuit pattern, which could result in smoking or catching fire. Do not locate any circuit pattern beneath the capacitor end seal.

9) Do not design a circuit board that the heat generating components are placed near the aluminum electrolytic capacitor or on the reverse side of PC board, if that just under the capacitor.

10) Electrical characteristics may vary depending on changes in temperature and frequency. Please consider this variation when you design circuits.

11) When you install more than 2 capacitors in parallel, please consider the balance of current flowing into the capacitors.

12) While mounting capacitors on double-side PC board, the capacitors should be away from those unnecessary base plate holes and connection holes.

## **MOUNTING**

1) Once a capacitor has been assembled in the set and power applied, do not attempt to re-use the capacitor in other circuits or application.

2) Leakage current of the capacitors that have been stored for more than 2 years may increase. When leakage current has increased, please perform a voltage treatment using a 1k $\Omega$  resistor.

3) Please confirm specifications and polarity before installing capacitors on the PC board.

4) Do not drop capacitors on the floor, nor use a capacitor that was dropped.

5) Do not deform the capacitor during installation.

6) Please pay attention to the mechanical shock to the capacitor by suction nozzle of the automatic insertion machine or automatic mounter, or by product checker, or by centering mechanism.

#### **REFLOW SOLDERING**

1) Please follow "Reflow Soldering Conditions" when use the part.

2) When an infrared heater is used, please pay attention to the extent of heating since the absorption rate of infrared will vary due to difference in the color and size of the capacitor.

3) Do not tilt lay down or twist the capacitor body after the capacitor are soldered to the PC board.

4) Do not carry the PC board by grasping the soldered capacitor.

5) Please do not allow anything to touch the capacitor after soldering. If PC boards are stored in stack, please make sure the PC board or other components away from the capacitor.

6) The capacitors shall not be effected by any radiated heat from the soldered PC board or other components after soldering.

7) Cleaning:

(a) Do not clean capacitors with halogenated cleaning agent. However, if it is necessary to clean with halogenated cleaning agent, please contact our sales team.

(b) Recommended cleaning method

Applicable : Any type, any ratings

Cleaning conditions: Total cleaning time shall be within 2 minutes by immersion, ultrasonic or other methods.

Temperature of the cleaning agents shall be 40°C or below. After cleaning, capacitors should be dried by using hot air for the minimum 10 minutes along with the PC board mounted. Hot air temperature should be within the maximum operating temperature of the capacitor. Insufficient dryness after water rinse may cause appearance problems, such as bottom-plate bulge and etc.;

Avoid using ozone destructive substances as cleaning agents for protecting global environment.

#### **IN THE EQUIPMENT**

1) Do not directly touch terminal by hand.

2) Do not link positive terminal and negative terminal by conductor, nor spill conductible liquid such as alkaline or acidic solution on or near the capacitor.

3) Please make sure that the ambient conditions where the set is installed are free from spilling water or oil, direct sunlight, ultraviolet rays, radiation, poisonous gases, vibration or mechanical shock.

#### **MAINTENANCE AND INSPECTION**

Please periodically inspect the aluminum capacitors that are installed in industrial equipment. The following items should be checked:

Appearance: remarkable abnormality such as pressure relief vent opening, electrolyte leaking, etc.

Electrical characteristics: capacitance, dielectric loss tangent, leakage current and etc., which are specified in catalogue or alternate product specification.

#### **IN AN EMERGENCY**

1) If you see smoke due to operation of safety vent, please turn off the main switch or pull out the plug from the outlet.

2) If you breathe the gas or ingest the electrolyte, please wash out your mouth and throat with water immediately.

3) If your skin is exposed to the electrolyte, please wash it away using soap and water.

#### **STORAGE**

1) Do not keep capacitor in high temperature and high humidity atmosphere. Storage conditions should be:

Temperature: 5°C~ 35°C Humidity : lower than 75% Place : Indoor

2) Avoid ambient conditions where capacitors are covered with water, brine or oil.

3) A storage products for longer than 12 months is not recommended. Within other effects, the terminals may suffer degradation, resulting in bad solderability. All products shall be used within the period of 12 months based on the day of shipment

#### **DISPOSAL**

Please take either of the following methods in disposing capacitors.

1) Incinerate them after crushing capacitors or making a hole on the capacitor body.

2) If incineration is not applicable, hand them over to a waste disposal agent and have them buried in landfills.

## IMPORTANT NOTES AND DISCLAIMER

1. **ROHS COMPLIANCE:** The levels of RoHS restricted materials in this product are below the maximum concentration values (also referred to as the threshold limits) permitted for such substances, or are used in an exempted application, in accordance with EU RoHS Directive (EU) 2015/863 EC (RoHS3). RoHS Test Report for this product can be obtained at Download Center.
2. **REACH COMPLIANCE:** REACH substances of high concern (SVHCs) information is available for this product. Since the European Chemical Agency (ECHA) has published notice of their intent to frequently revise the SVHC listing for the foreseeable future, REACH Test Report for this product can be obtained at Download Center.
3. All Product parametric performance is indicated in the Electrical Characteristics for the listed herein test conditions, unless otherwise noted. Product performance may not be indicated by the Electrical Characteristics if operated under different conditions.
4. NextGen Component, Inc (*NextGen*) reserves the right to make changes to this document and its products and specifications at any time without notice. Customers should obtain and confirm the latest product information and specifications before final design, purchase or use.
5. *NextGen* makes no warranty, representation or guarantee regarding the suitability of its products for any particular purpose, not does *NextGen* assume any liability for application assistance or customer product design.
6. *NextGen* does not warrant or accept any liability with products which are purchased or used for any unintended or unauthorized application. No license is granted by implication or otherwise under any intellectual property rights of NextGen.
7. *NextGen* products are not authorized for use as critical components in life support devices or systems without express written approval by *NextGen*.
8. *NextGen* requires that customers first obtain an RMA (Returned Merchandise Authorization) number prior to returning any products. Returns must be made within 30 days of the date of invoice, be in the original packaging, unused and like-new condition. At the time of quoting or purchasing, a product may say that it is Non-Cancelable/ Non-Returnable (NCNR). These products are not returnable and not refundable.