



SPECIFICATION SHEET NO.	S0207- B0603W475K160K	
ORIGINAL MFG/PART NO.	Eyang MLCC/B0603X5R475K160NTK	
NEXTGEN PART CODE	B0603W475K160K	Indicate This Code For RFQ Order
DATE	Feb. 7, 2025	
REVISION	A1	Updated With Most Recent Data
DESCRIPTION AND MAIN PARAMETRICS	<p>Industrial Grade MLCC, B Series Case 0603, Metric 1608</p> <p>Dimension L1.60*W0.80*H0.80mm, Thickness: 1.0mm Max.</p> <p>Temperature Characteristics X5R, Capacitance 4.7 μF, Tolerance ±10%</p> <p>Rated Voltage 16V, Terminal Electrodes Type Cu and Plating Material Ni/Sn</p> <p>Operating Temp. Range -55°C ~+85°C</p> <p>Package in Tape/Reel, 4,000pcs/Reel</p> <p>REACH/RoHS/RoHS III Compliant</p>	
CUSTOMER		
CUSTOMER PART NUMBER		
CROSS REF. PART NUMBER		
MEMO		

VENDOR APPROVE		
Issued/Checked/Approved		 
Effective Date: Feb. 7, 2025		

CUSTOMER APPROVE
DATE:

DESCRIPTION

MLCC consists of a conducting material and electrodes. To manufacture a chip-type SMT and achieve miniaturization, high density and high efficiency, ceramic condensers are used. MLCC is made by NP0 (COG), X7R, X7S, X7T, X5R And X6S dielectric material and which provides product with high electrical precision, stability and reliability.



Image shown is a representation only. Exact specifications should be obtained from the product dimension.

MAIN FEATURE

- Temperature Characteristics:
Class 1 (Temperature Compensating Type): COG
Class 2 (High dielectric constant type): X7R, X7S, X7T, X6S and X5R
- Size Code: 0105(01005), 0201, 0402, 0603, 0805, 1206 and 1210
- Capacitance : 0.1pF~100μF
- Terminal Electrodes Type Cu and Plating Material Ni/Sn
- Industrial Grade Multilayer Ceramic Chip Capacitors
- REACH/RoHS/RoHS III Compliant



APPLICATION

- General Digital Circuit
- Power Supply by pass capacitors
- Consumer Electronics
- Telecommunication

ELECTRICAL CHARACTERISTICS

- See Page 5 For Different Part Code And Rated Voltage.
- All Products Parameters are Subject To NextGen Components' Final Confirmation.

HOW TO ORDER

- Please Follow Up Part Code Guide And Indicate NextGen Part Code
B0603W475K160K For RFQ and Order.

PART CODE GUIDE

CODE	NAME	KEY SPECIFICATION OPTION
B	Series Code	A: Automotive Grade AEC-Q200 MLCC; B: Industrial Grade MLCC C: General Purpose Medium-High Voltage MLCC E: Automotive Powertrain & Safety Grade AEC-Q200 MLCC P: High Q and High Power MLCC; Q: High Q Automotive Grade AEC-Q200 MLCC U: High Q MLCC (Internal Electrodes: Cu)
0603	Case Size	0201 (0603 Metric): L0.60*W0.30mm; 0402 (1005 Metric): L1.00*W0.50mm 0603 (1608 Metric): L1.60*W0.80mm; 0805 (2012 Metric): L2.00*W1.25mm 1206 (3216 Metric): L3.20*W1.60mm; 1210 (3225 Metric): L3.20*W2.50mm 1812 (4532 Metric): L4.50*W3.20mm; 1825 (4563 Metric):L4.50*W6.30mm 2220 (5750 Metric): L5.70*W5.00mm; 2225 (5763 Metric): L5.70*W6.30mm
W	Temperature Characteristics	N: NPO (COG); B: X7R; W: X5R; S: X6S; Y: Y5V; T: X7S; R: X7T, Please see page 6
475	Capacitance	Two significant digits followed by number of Zero, The 3rd digit signifies the multiplying factor, and letter R is decimal point. 8R2: 8.2pF; 820: 82pF; 332: 3300pF; 680: 68pF; 511: 510pF; 475: 4.7μF
K	Capacitance Tolerance	A: ±0.05pF; B: ±0.1pF; C: ±0.25pF; D: ±0.5pF; F: ±1%; G: ±2%; J: ±5%; K: ±10% L: ±15%; M: ±20%; N: ±30%; P: ±0.02pF; X: ±40%; S: 50%/-20%; Y: 150%/-20% Z: 80%/-20%
160	Rated Voltage	Two significant digits followed by No. of zeros. "R" is in place of decimal point. 6R3: 6.3VDC; 160: 16 VDC; 250: 25 VDC; 500: 50 VDC; 101: 100VDC
K	Case Thickness	K: 0.80+0.20/-0.10mm, See Page 4 (T's Symbol) for Different part code
XX	Internal Control Code	Blank: N/A; XX: Letter A~Z, a~z or digits (0~9) for Special/Custom Parameters

DIMENSION (Unit: mm)

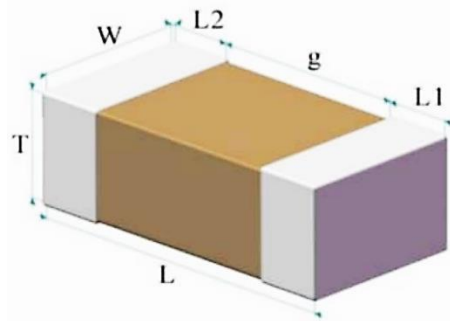

SIZE CODE	METRIC CODE	L	W	L1, L2	g	THICKNESS	
						T	Code
0402	1005	1.00 ±0.05	0.50 ±0.05	0.15~0.35	0.30min.	0.50 ±0.05	B
0402	1005	1.00 +0.15/-0.05	0.50 +0.15/-0.05	0.15~0.35	0.30min.	0.50 +0.15/-0.05	N
0402	1005	1.00 +0.20/-0.05	0.50 +0.20/-0.05	0.15~0.35	0.30min.	0.50 +0.20/-0.05	C
0402	1005	1.00 +0.30/-0.05	0.50 +0.30/-0.05	0.15~0.35	0.30min.	0.50 +0.30/-0.05	U
0603	1608	1.60 +0.20/-0.10	0.80 +0.20/-0.10	0.20~0.50	0.50min.	0.45 ±0.05	S
0603	1608	1.60 ±0.10	0.80 ±0.10	0.20~0.50	0.50min.	0.80 ±0.10	D
0603	1608	1.60 +0.20/-0.10	0.80 +0.20/-0.10	0.20~0.50	0.50min.	0.80 +0.20/-0.10	K
0603	1608	1.60 +0.30/-0	0.80 +0.30/-0	0.20~0.50	0.50min.	0.80 +0.30/-0	W

ELECTRICAL CHARACTERISTICS - FOR DIFFERENT PART CODE

NEXTGEN PART CODE	TEMP. COEFFICIENT	CAPACITANCE	TOLERANCE	VOLTAGE	THICKNESS (MAX.)	OPERATING TEMP. RANGE	CAPACITANCE CHARACTERISTIC
	-	-	-	V	mm	°C	-
B0402W475M6R3C	X5R	4.7 μ F	\pm 20%	6.3	0.70	-55 ~+85	\pm 15%
B0603W106M6R3K	X5R	10 μ F	\pm 20%	6.3	1.00	-55 ~+85	\pm 15%
B0603W475K160K	X5R	4.7 μ F	\pm 10%	16	1.00	-55 ~+85	\pm 15%
B0603N100F500D	NP0(C0G)	10 pF	\pm 1%	50	0.90	-55°C~125°C	0 \pm 30ppm/°C
B0603N5R6C500D	NP0(C0G)	5.6 pF	\pm 0.25 pF	50	0.90	-55°C~125°C	0 \pm 30ppm/°C

TEMPERATURE CHARACTERISTICS

TEMPERATURE CHARACTERISTICS	OPERATING TEMP. RANGE	TEMPERATURE CHARACTERISTICS		
		TEMP. COEFF. Or CAP. CHANGE	TEMP. RANGE	REF. TEMP.
C0G	-55°C~125°C	0±30ppm/°C	25°C~125°C	25°C
X7R	-55°C~125°C	±15%	-55°C~125°C	25°C
X7S	-55°C~125°C	±22%	-55°C~125°C	25°C
X7T	-55°C~125°C	+22%/-33%	-55°C~125°C	25°C
X6S	-55°C~105°C	±22%	-55°C~105°C	25°C
X5R	-55°C~85°C	±15%	-55°C~85°C	25°C

TERMINATION TYPE

CODE	TERMINAL ELECTRODES	PLATING MATERIAL
N	Cu	Ni/Sn
P	Cu+AgPd or Cu+AgPdCu	
C	Cu	Cu
K	Cu	Ni/Au
T	Cu/Ag (Resin)	Ni/Sn

CAPACITANCE TABLE - CLASS1-C0G

SIZE CODE	METRIC CODE	TEMPERATURE CHARACTERISTICS	RATED VOLTAGE	THICKNESS CODE	CAPACITANCE
0402	1005	C0G	50V	B	0.1pF ~ 4.7nF
0402	1005	C0G	50V	N	2.4nF ~ 4.7nF
0402	1005	C0G	25V	B	0.1pF ~ 4.7nF
0402	1005	C0G	25V	N	2.4nF ~ 4.7nF
0402	1005	C0G	16V	N	2.4nF ~ 10nF
0402	1005	C0G	16V	B	0.1pF ~ 4.7nF
0603	1608	C0G	50V	D	1pF~10nF
0603	1608	C0G	25V	D	1pF~10nF
0603	1608	C0G	16V	D	1pF~10nF

CAPACITANCE TABLE - CLASS 2- X7R

SIZE CODE	METRIC CODE	TEMPERATURE CHARACTERISTICS	RATED VOLTAGE	THICKNESS CODE	CAPACITANCE
0402	1005	X7R	50V	B	100pF~100nF
0402	1005	X7R	50V	N	100nF
0402	1005	X7R	50V	C	100nF
0402	1005	X7R	25V	B	100pF~100nF
0402	1005	X7R	25V	N	22nF~330nF
0402	1005	X7R	25V	C	82nF~220nF
0402	1005	X7R	16V	B	1nF~220nF
0402	1005	X7R	16V	N	22nF~470nF
0402	1005	X7R	10V	B	1nF~220nF
0402	1005	X7R	10V	N	22nF~470nF
0402	1005	X7R	6.3V	B	1nF~220nF
0402	1005	X7R	6.3V	N	22nF~470nF
0402	1005	X7R	6.3V	N	1μF
0603	1608	X7R	50V	D	220pF~820nF
0603	1608	X7R	50V	K	47nF~470nF
0603	1608	X7R	25V	D	100nF~820nF
0603	1608	X7R	25V	D	1μF
0603	1608	X7R	25V	K	100nF~1μF
0603	1608	X7R	16V	D	1nF~1μF
0603	1608	X7R	16V	K	100nF~1μF

CAPACITANCE TABLE - CLASS 2-X7R\X5R

SIZE CODE	METRIC CODE	TEMPERATURE CHARACTERISTICS	RATED VOLTAGE	THICKNESS CODE	CAPACITANCE
0603	1608	X7R	10V	D	100nF~820nF
0603	1608	X7R	10V	D	2.2μF
0603	1608	X7R	10V	K	100nF~1μF
0603	1608	X7R	10V	K	2.2μF
0603	1608	X7R	6.3V	D	100nF~820nF
0603	1608	X7R	6.3V	K	100nF~1μF
0603	1608	X7R	6.3V	K	2.2μF
0603	1608	X7R	6.3V	K	4.7μF
0402	1005	X5R	50V	B	100pF~100nF
0402	1005	X5R	50V	N	27nF~47nF
0402	1005	X5R	50V	C	56nF~470nF
0402	1005	X5R	35V	B	100pF~100nF
0402	1005	X5R	35V	C	56nF~100nF
0402	1005	X5R	25V	B	100pF~1μF
0402	1005	X5R	25V	N	82nF~470nF
0402	1005	X5R	25V	C	270nF~2.2μF
0402	1005	X5R	16V	B	100pF~1μF
0402	1005	X5R	16V	N	120nF~470nF
0402	1005	X5R	16V	N	2.2μF
0402	1005	X5R	10V	B	100pF~1μF

CAPACITANCE TABLE - CLASS 2- X5R

SIZE CODE	METRIC CODE	TEMPERATURE CHARACTERISTICS	RATED VOLTAGE	THICKNESS CODE	CAPACITANCE
0402	1005	X5R	10V	B	2.2μF
0402	1005	X5R	10V	N	120nF~470nF
0402	1005	X5R	10V	N	2.2μF
0402	1005	X5R	10V	C	4.7μF
0402	1005	X5R	6.3V	B	100nF~820nF
0402	1005	X5R	6.3V	B	1μF
0402	1005	X5R	6.3V	B	2.2μF
0402	1005	X5R	6.3V	N	270nF~4.7μF
0402	1005	X5R	6.3V	C	4.7μF
0402	1005	X5R	6.3V	C	10μF
0402	1005	X5R	6.3V	U	10μF
0402	1005	X5R	4V	C	10μF
0402	1005	X5R	4V	C	22μF
0603	1608	X5R	50V	D	220pF~820nF
0603	1608	X5R	50V	D	1μF
0603	1608	X5R	50V	K	2.2μF
0603	1608	X5R	35V	D	680nF~820nF
0603	1608	X5R	25V	S	680nF~820nF
0603	1608	X5R	25V	D	100nF~820nF
0603	1608	X5R	25V	D	1μF

CAPACITANCE TABLE - CLASS 2- X7S\X7T\X6S

SIZE CODE	METRIC CODE	TEMPERATURE CHARACTERISTICS	RATED VOLTAGE	THICKNESS CODE	CAPACITANCE
0603	1608	X7S	16V	K	4.7μF
0603	1608	X7S	10V	K	4.7μF
0603	1608	X7S	6.3V	K	4.7μF
0402	1005	X7T	10V	B	1μF
0402	1005	X7T	10V	C	2.2μF
0402	1005	X7T	6.3V	B	1μF
0402	1005	X7T	6.3V	N	2.2μF
0402	1005	X7T	6.3V	C	4.7μF
0402	1005	X7T	4V	N	4.7μF
0603	1608	X7T	10V	K	2.2μF~10μF
0603	1608	X7T	6.3V	K	10μFF
0402	1005	X6S	50V	B	15nF~47nF
0402	1005	X6S	50V	C	100nF
0402	1005	X6S	25V	B	68nF~100nF
0402	1005	X6S	25V	C	220nF~1.0μF
0402	1005	X6S	25V	N	220nF~470nF
0402	1005	X6S	16V	B	100nF~1μF
0402	1005	X6S	16V	N	220nF~470nF
0402	1005	X6S	16V	C	220nF
0402	1005	X6S	16V	C	1μF

CAPACITANCE TABLE - CLASS 2- X6S

SIZE CODE	METRIC CODE	TEMPERATURE CHARACTERISTICS	RATED VOLTAGE	THICKNESS CODE	CAPACITANCE
0402	1005	X6S	16V	C	2.2 μ F
0402	1005	X6S	10V	B	1 μ F
0402	1005	X6S	10V	N	220nF~470nF
0402	1005	X6S	10V	N	4.7 μ F
0402	1005	X6S	10V	C	2.2 μ F
0402	1005	X6S	6.3V	B	1 μ F
0402	1005	X6S	6.3V	N	220nF~470nF
0402	1005	X6S	6.3V	N	2.2 μ F
0402	1005	X6S	6.3V	C	1 μ F~4.7 μ F
0402	1005	X6S	4V	B	2.2 μ F~10 μ F
0402	1005	X6S	4V	C	10 μ F
0603	1608	X6S	25V	K	2.2 μ F
0603	1608	X6S	25V	K	4.7 μ F
0603	1608	X6S	16V	D	1 μ F
0603	1608	X6S	16V	K	2.2 μ F~10 μ F
0603	1608	X6S	10V	K	10 μ F
0603	1608	X6S	6.3V	D	4.7 μ F
0603	1608	X6S	6.3V	K	4.7 μ F
0603	1608	X6S	6.3V	K	10 μ F
0603	1608	X6S	6.3V	W	22 μ F

CAPACITANCE TABLE - CLASS 2- X6S

SIZE CODE	METRIC CODE	TEMPERATURE CHARACTERISTICS	RATED VOLTAGE	THICKNESS CODE	CAPACITANCE
0603	1608	X6S	4V	K	10µF
0603	1608	X6S	4V	K	22µF
0603	1608	X6S	4V	W	22µF
0603	1608	X6S	2.5V	K	47µF

STORAGE CONDITIONS

- Storage conditions: The recommended temperature is less than 30°C. A temperature is +5°C to +40°C and a relative humidity is 20% to 70% as a standard condition. (MSL Level 1) MLCC may be affected by the storage conditions. Please use them promptly after delivery. High temperature and humidity conditions and/or prolonged storage may cause deterioration of the packaging materials. If more than six months have elapsed since delivery, check packaging, mounting, etc. before use.
- Corrosive gas can react with the termination (external) electrodes or lead wires of capacitors, and result in poor solderability. Do not store the capacitors in an atmosphere consisting of corrosive gas (e.g. hydrogen sulfide, sulfur dioxide, chlorine, ammonia gas etc.)

MLCC APPLICATION OF TECHNICAL REQUIREMENTS

- Circuit Design

Operating Temperature: a. Do not use capacitor above the maximum allowable operating temperature. b. Surface temperature including self-heating should be below maximum operating temperature.

Operating Voltage: The operating voltage for capacitors must always be lower than their rated voltage.

- PCB Design

Design of Land-patterns: When the capacitors are mounted on a PCB, the amount of solder at the terminations has a direct effect on the performance of the capacitors. The greater the amount of solder, the higher the stress on the capacitor. Therefore, when designing land-patterns, it is necessary to consider the appropriate size and configuration of the solder pads. Size and recommended land dimensions are shown in the following figure and table

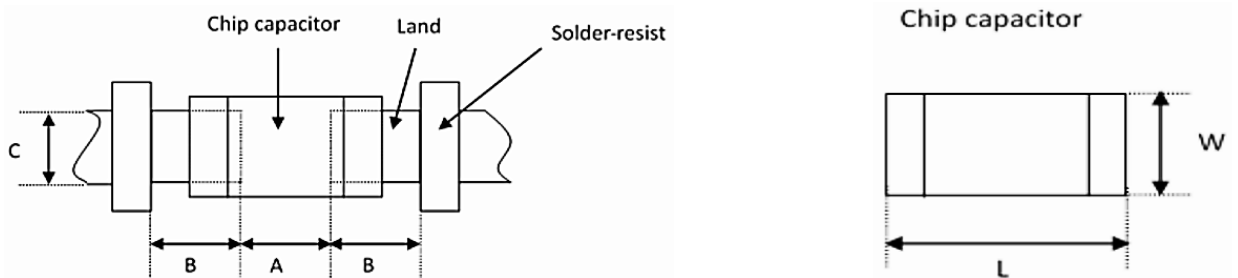

Recommended land dimensions for reflow-soldering (Unit: mm):

SIZE CODE	METRIC CODE	LENGTH	WIDTH	TOLERANCE	A	B	C
0402	1005	1	0.5	±0.05	0.30~0.50	0.35~0.45	0.40~0.60
0402	1005	1	0.5	±0.15 or ±0.20	0.40~0.60	0.40~0.50	0.50~0.70
0603	1608	1.6	0.8	±0.10	0.60~0.80	0.60~0.70	0.60~0.80
0603	1608	1.6	0.8	±0.20	0.70~0.90	0.70~0.80	0.80~1.00

Capacitor Layout on PC Board: Mechanical stress varies according to the location of capacitors on PC board. The recommendation for better design is as follows

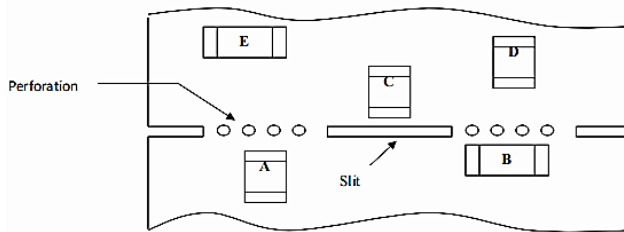

The stress in capacitors is in the following order: A>B=C>D>E

Pay attention not to bend or distort the PC board otherwise the capacitor may crack. Please refer to the following examples of good and bad capacitor layout.

Not recommended:

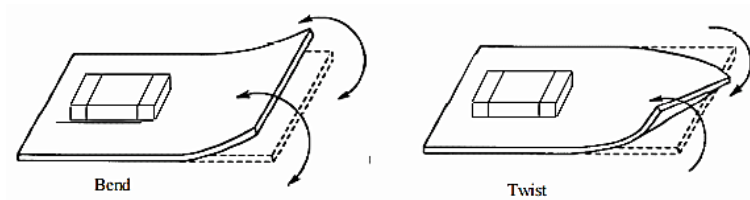

Recommended:

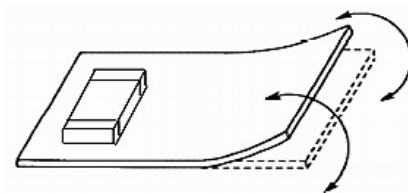

Solder Buildup and Soldering:

a. Examples of soldering method not recommended

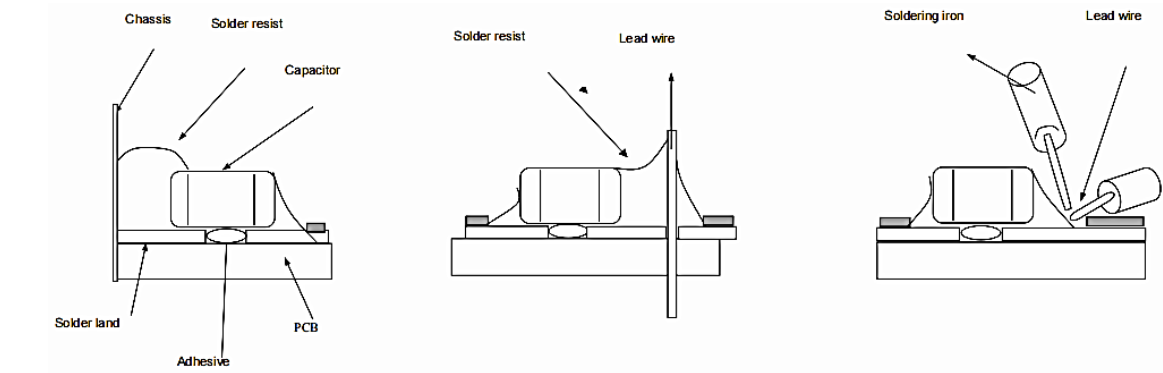

b. Examples of soldering method recommended

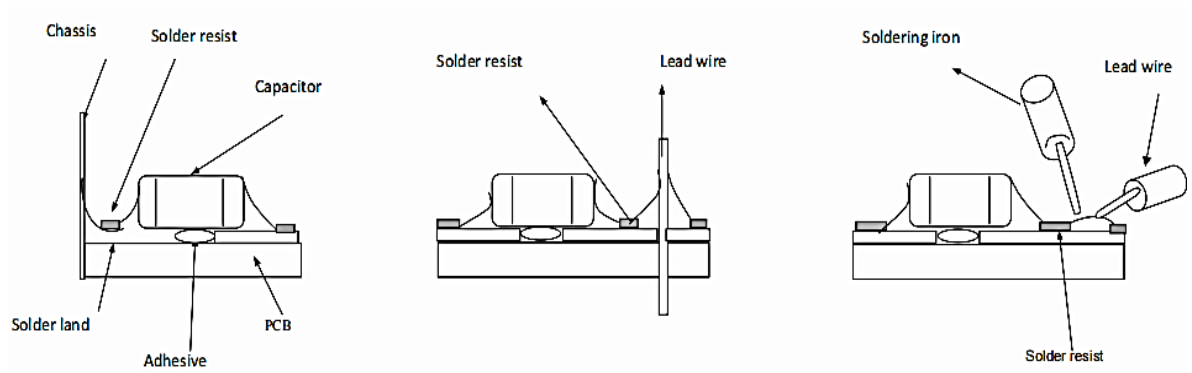

- Consideration for Automatic Placement

If the mounting head is adjusted too low, it may induce excessive stress in the chip capacitor to result in cracking.

Please take following precautions

- Adjust the bottom dead center of the mounting head to reach on the PC board surface and not press it;
- Adjust the mounting head pressure to be 1N to 3N of static weight;
- To minimize the impact energy from mounting head, it is important to provide support from the bottom side of the PC board.

Please refer to the following samples:

- Consideration for Automatic Placement

If the mounting head is adjusted too low, it may induce excessive stress in the chip capacitor to result in cracking.

Please take following precautions

- Adjust the bottom dead center of the mounting head to reach on the PC board surface and not press it ;
- Adjust the mounting head pressure to be 1N to 3N of static weight ;
- To minimize the impact energy from mounting head, it is important to provide support from the bottom side of the PC board.

Please refer to the following samples:

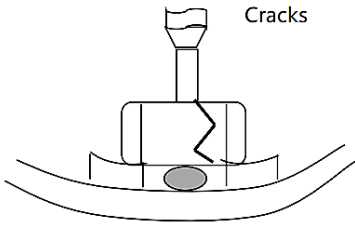
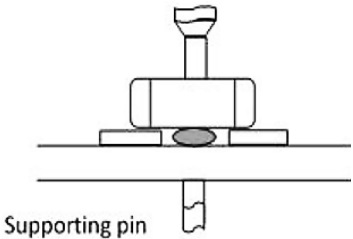
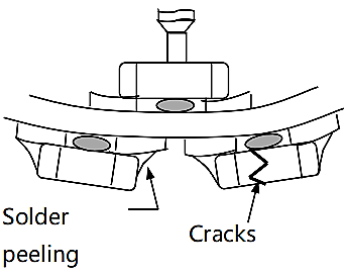
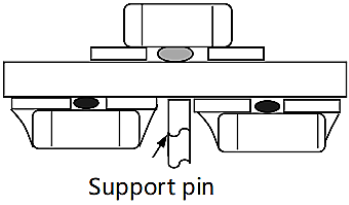
MOUNTING	NOT RECOMMENDED	RECOMMENDED
Single - sided Mounting		
Double-sided Mounting		

- Recommended Profile Conditions Part I– Fore Reference Only

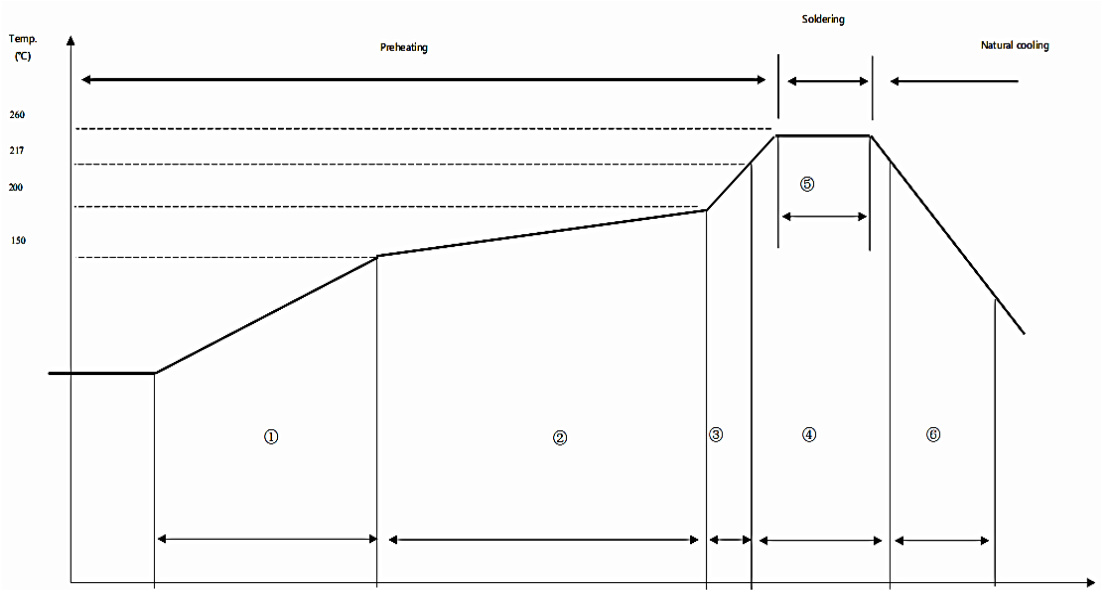

NO.	REFLOW SOLDERING ZONE	REFLOW SOLDERING CONDITION
①	Preheating 1	$\leq 3^{\circ}\text{C/s}; \geq 60\text{s}$
②	Constant temperature	$150 \sim 200^{\circ}\text{C}; 60 \sim 120\text{s}; \leq 1^{\circ}\text{C/s}$
③	Preheating 1	$1 \sim 5^{\circ}\text{C/s}$
④	Soldering 1	Above 217°C , $60 \sim 150\text{s}$
⑤	Soldering 1	Above 260°C , over 10s
⑥	Natural cooling	$\leq 6^{\circ}\text{C/s}$

- Recommended Profile Conditions Part II – Fore Reference Only

a. Excessive solder will induce higher tensile force in chip capacitor when temperature changes and result in cracking. Insufficient solder may detach the capacitor from the PC board. The ideal condition is to have solder mass controlled to $1/2$ to $1/3$ of the thickness of the capacitor.

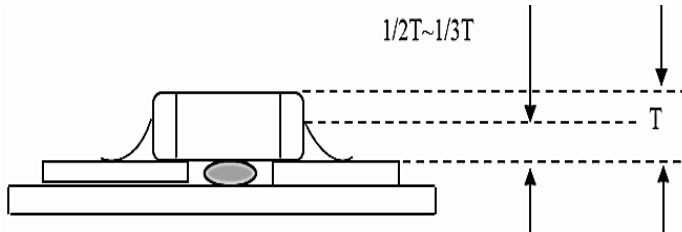

b. Soldering duration should be kept as close to recommended times as possible, because excessive duration can detrimentally affect solderability.

c. The peak temperature of reflow soldering is $245 \pm 15^\circ\text{C}$

TECHNICAL SPECIFICATIONS AND TEST METHODS

Operating Environment:

TEMP. CHARACTERISTICS	TEMP. RANGE	RELATIVE HUMIDITY	ATMOSPHERIC PRESSURE
COG/X7R/X7S/X7T	-55°C ~ 125°C	≤95% (25°C)	86 KPa~106KPa
X6S	-55°C ~ 105°C	≤95% (25°C)	86 KPa~106KPa
X5R	-55°C ~ 85°C	≤95% (25°C)	86 KPa~106KPa

Reliability Test Specifications and Methods Part A:

Without specific note, the “test method” in Table 5 is based on GB/T 21041/21042 IDT IEC60384 .

Item	Specification	Test Method
	Class1 (Temperature Compensating Type)- COG, Class 2 (High dielectric constant type)- X7R\X7T\X7S\X6S\X5R	
Appearance	No obvious defects on ceramic body and termination	Visual examination under a microscope.
Size Code	See Page 4	Measuring by gages which precision is not less than 0.01 mm .
Capacitance	Within the specified tolerance	Measurement Temperature: 18 ~ 28°C Relative Humidity: ≤RH 80% Measurement Frequency: Class 1: C≤1nF, f=1.0±0.1MHz ; C>1nF, f=1.0±0.1KHz Class 2: f=1.0±0.1KHz, 120±24Hz, Page 28~Page 71 Measurement Voltage: Class 1: 1.0±0.2Vrms; Class 2: U=1.0±0.2Vrms, 0.5±0.1Vrms,
Dissipation	Class 1: C≥30pF, Q≥1000, C < 30pF, Q≥400+20C, C: Nominal Capacitance (pF) Class 2: see Page 28~Page 71	see Page 28~Page 71 Post-treatment: When the capacitor initial capacitance is lower than its tolerance value, the test sample need to Perform a heat treatment at 150°C+0/-10°C for 1 hour and then set for 24±2 hours at room temp. then measure.

Reliability Test Specifications and Methods Part F:

Without specific note, the “test method” in Table 5 is based on GB/T 21041/21042 IDT IEC60384 .

Item	Specification	Test Method
Insulation Resistance (I.R.)	Class1 (Temperature Compensating Type)- COG, Class 2 (High dielectric constant type)- X7R\X7T\X7S\X6S\X5R	Measurement Temperature: 18 ~ 28°C Relative Humidity: ≤RH 80% Measurement Voltage: Rated Voltage Charging Time: 1min Charge/discharge current: 50mA or lower. .
Voltage Proof	No defects or abnormalities.	Test Voltage: Class 1: ≥3×UR, Class 2: ≥2.5×UR Applied Time: t=1s~5s Charge/discharge current: 50mA or lower.
Temperature Characteristics of Capacitance	Class 1: COG: $\alpha \leq \pm 30 \text{ ppm}/^\circ\text{C}$ (125°C $-72 \leq \alpha \leq +30 \text{ ppm}/^\circ\text{C}$ (-55°C) Class 2: X7R/X5R: $\Delta C/C \leq \pm 15\%$. X7S/X6S: $\Delta C/C \leq \pm 22\%$; X7T: $-33\% \leq \Delta C/C \leq 22\%$	Pre-treatment: Class 2: Perform a heat treatment at 150°C+0/-10°C for 1 hour and then sit for 24±2 hours at room temperature. then measure. Pre-drying: Class 1: 16-24 hours Measure the capacitance separately in 25°C、 θ_1 、25°C、 θ_2 、25°C, should satisfied relative capacitance change characteristics COG\X7R\X7S\X7T: $\theta_1 = -55^\circ\text{C}$, $\theta_2 = 125^\circ\text{C}$ X6S: $\theta_1 = -55^\circ\text{C}$, $\theta_2 = 105^\circ\text{C}$ X5R: $\theta_1 = -55^\circ\text{C}$, $\theta_2 = 85^\circ\text{C}$ T.C Measurement Voltage: Class 1: 1.0±0.2Vrms Class 2: ≤1.0±0.2Vrms ※ 【※ Please contact our technical support staff for more

Reliability Test Specifications and Methods Part G:

Without specific note, the “test method” in Table 5 is based on GB/T 21041/21042 IDT IEC60384 .

Item	Specification	Test Method
Resistance to Soldering Heat	Class1 (Temperature Compensating Type)- COG, Class 2 (High dielectric constant type)- X7R\X7T\X7S\X6S\X5R	Test Method Pre-treatment: Class 2: Perform a heat treatment at 150°C+0/-10°C for 1 hour and then sit for 24±2 hours at room temperature. then measure. Test Method: Solder bath method Pre-heating: Temp. : 120°C~150°C/Time: 60s Solder alloy: Sn-3.0Ag-0.5Cu(Lead Free Solder) Solder temp.: (270±5)°C Duration of immersion: (10±1)s Depth of immersion: 10 mm Post-treatment: Set for 24±2 hours at room temperature, then measure.
Solderability	Appearance 95% of the terminations is to be Time:10s~30s soldered evenly and continuously	Pre-heating: 80°C~120°C,Time:10s~30s Test Method Solder bath method Flux Solution of rosin ethanol Solder alloy Sn-Ag-Cu(Lead Free Solder) Solder temp. (245±5)°C Duration of immersion (2.0±0.5)s Depth of immersion 10 mm

Reliability Test Specifications and Methods Part D:

Without specific note, the “test method” in Table 5 is based on GB/T 21041/21042 IDT IEC60384 .

Item	Specification	Test Method
Substrate Bending test	Appearance: No defects or abnormalities, Cap. Change : Class 1: $\Delta C/C \leq \pm 5\%$ or $\pm 0.5pF$, (Whichever is larger) Class 2: See Page 28~Page 71	Mounting method: Solder the capacitor on the test substrate shown in Fig.2 Pressurization Method: Shown in Fig.3 Flexure: 1mm Holding Time: (5±1)s then measure the capacitance

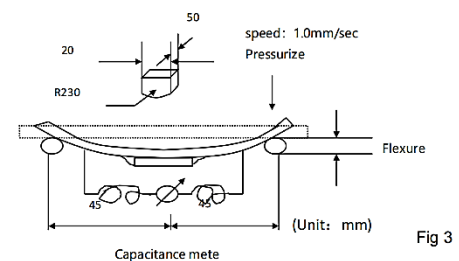
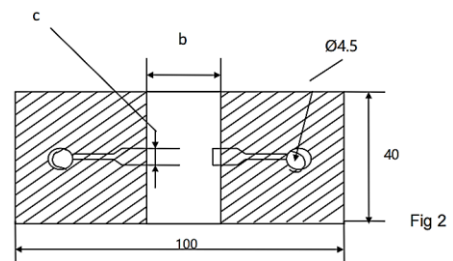

Reliability Test Specifications and Methods Part E:

Without specific note, the “test method” in Table 5 is based on GB/T 21041/21042 IDT IEC60384 .

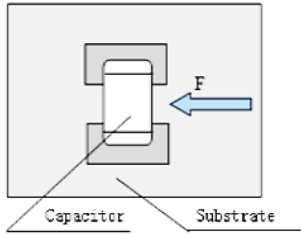
Item	Specification	Test Method
<p>Adhesive Strength of Termination</p>	<p>Class1 (Temperature Compensating Type)- COG, Class 2 (High dielectric constant type)- X7R\X7T\X7S\X6S\X5R</p> <p>Appearance: No defects or abnormalities</p>	<p>Mounting method Solder: the capacitor on the test substrate shown in Fig.4</p> <p>Apply a pushing force of F for 10±1secs.</p> <p>Pushing force: 0105:F=1N/0201:F=2N/0402:F=5N Class1: 0603/0805/1206/1210:F=10N Class2: 0603/0805/1206/1210:F=5N.</p> <div data-bbox="868 998 1165 1230" style="text-align: center;">  <p>The diagram shows a cross-section of a capacitor mounted on a substrate. A blue arrow labeled 'F' points to the right, indicating the direction of the pushing force applied to the capacitor.</p> </div> <p style="text-align: center;">Fig 4</p>
<p>Vibration</p>	<p>Appearance: No defects or abnormalities</p> <p>Cap. Change: Class1: initial specification Class 2: See Page 28~Page 71</p> <p>I.R. initial specification D.F. or Q: initial specification</p>	<p>Mounting method: Solder the capacitor on the test substrate</p> <p>Amplitude: 1.5mm</p> <p>Kind of Vibration: A simple harmonic motion</p> <p>Frequency: 10Hz-55Hz-10Hz</p> <p>Vibration Time: 1 min</p> <p>Repeat this for 2hrs each in 3 perpendicular directions X, Y, Z, total 6hrs</p>

Reliability Test Specifications and Methods Part F:

Without specific note, the “test method” in Table 5 is based on GB/T 21041/21042 IDT IEC60384 .

Item	Specification	Test Method
Rapid change of temperature	Class1 (Temperature Compensating Type)- COG, Class 2 (High dielectric constant type)- X7R\X7T\X7S\X6S\X5R	Pre-treatment: Class 2: Perform a heat treatment at 150°C+0/-10°C for 1 hour and then sit for 24±2 hours at room temperature. then measure. Mounting method: Solder the capacitor on the test substrate The number of cycles: 100 cycles Temperature Step : Step 1: Temp.(°C) θ_1 , Time (min.) 30±3 Step 2: Temp.(°C) 25, Time (min.) 2~5 Step 3: Temp.(°C) θ_2 , Time (min.) 30±3 Step 4: Temp.(°C) 25, Time (min.) 2~5 COG\X7R\X7S\X7T: $\theta_1=-55^{\circ}\text{C}$, $\theta_2=125^{\circ}\text{C}$ X6S: $\theta_1=-55^{\circ}\text{C}$, $\theta_2=105^{\circ}\text{C}$ X5R: $\theta_1=-55^{\circ}\text{C}$, $\theta_2=85^{\circ}\text{C}$ Post-treatment: Set for 24±2 hours at room temperature, then measure.
Damp Heat (Steady State)	Appearance: No defects or abnormalities Cap. Change: Class 1: $\Delta C/C \leq \pm 7.5\%$ or 0.75pF, (Whichever is larger) Class 2: See Page 28~Page 71 I.R.: Class 1: $\geq 500\text{M}\Omega$ or 25 Ω , (Whichever is larger), Class 2: Page 28~Page 71 D.F. or Q: Class 1: $C \geq 30\text{pF}$, $Q \geq 200$ C < 30pF $Q \geq 100 + 10C/3$, C: Nominal Capacitance (pF) Class 2: See Page 28~Page 71	Pre-treatment: Class 2: Perform a heat treatment at 150°C+0/-10°C for 1 hour and then sit for 24±2 hours at room temperature. then measure. Mounting method: Solder the capacitor on the test substrate Test Temperature: 60±2°C Test Humidity: RH 90 ~ 95% Test Time 500±12h Post-treatment: set for 24±2 hours at room temperature, then measure.

Reliability Test Specifications and Methods Part G:

Without specific note, the “test method” in Table 5 is based on GB/T 21041/21042 IDT IEC60384 .

Item	Specification	Test Method
Endurance	<p>Class1 (Temperature Compensating Type)- C0G,</p> <p>Class 2 (High dielectric constant type)- X7R\X7T\X7S\X6S\X5R</p>	<p>Test Method</p> <p>Pre-treatment: Class 2: Perform a heat treatment at 150°C+0/-10°C for 1 hour and then sit for 24±2 hours at room temperature. then measure.</p> <p>Mounting method: Solder the capacitor on the test substrate</p> <p>Test Temperature: $\theta_2 \pm 3^\circ\text{C}$ [C0G\X7R\X7S\X7T: $\theta_2 = 125^\circ\text{C}$, X6S: $\theta_2 = 105^\circ\text{C}$, X5R: $\theta_2 = 85^\circ\text{C}$]</p> <p>Test Time: 1000±12h</p> <p>Test Voltage: Class 1: $2 \times \text{UR}$ [0201C0G:C≥270pF and UR=50V: 1.5×UR], Class 2: 1.5×UR</p> <p>Charge/discharge current: 50mA or lower</p> <p>Post-treatment: Class 1: Set for 24±2 hours at room temperature, then measure. Class 2: Perform a heat treatment at 150°C+0/-10°C for 1 hour and then sit for 24±2 hours at room temperature. then measure.</p>

CAP. \ D.F \ I.R. CHANGES AFTER TEST X7R, 0402 - 50V

THICKNESS CODE		B (50V)	N (50V)	C (50V)
Capacitance		100pF~100nF	100nF	100nF
Electrical tests	D.F. [max.]	0.035	0.035	0.035
	I.R. [min.]	C≤25nF:10000MΩ, C>25nF:50Ω.F	50Ω.F	50Ω.F
	Measurement Frequency	1.0±0.1KHz	1.0±0.1KHz	1.0±0.1KHz
	Measurement Voltage [Vrms]	1.0±0.2	1.0±0.2	1.0±0.2
Resistance to soldering heat	Cap. [ΔC/C≤±%]	15	15	15
Substrate Bending test	Cap. [ΔC/C≤±%]	10	10	10
Vibration	Cap.[ΔC/C≤±%]	15	15	15
Rapid change of temperature	Cap. [ΔC/C≤±%]	15	15	15
Damp heat (steady state)	Cap. [ΔC/C≤±%]	12.5	12.5	12.5
	D.F. [max.]	0.07	0.07	0.07
	I.R. [min.]	500MΩ or 12.5Ω.F	500MΩ or 12.5Ω.F	500MΩ or 12.5Ω.F
High Temperature High Humidity (Steady)	Cap.[ΔC/C≤±%]	12.5	12.5	12.5
	D.F. [max.]	0.07	0.07	0.07
	I.R. [min.]	500MΩ or 12.5Ω.F	500MΩ or 12.5Ω.F	500MΩ or 12.5Ω.F
Endurance	Cap.[ΔC/C≤±%]	15	15	15
	D.F. [max.]	0.07	0.07	0.07
	I.R. [min.]	1000MΩ or 25Ω.F	1000MΩ or 25Ω.F	1000MΩ or 25Ω.F

CAP. \ D.F \ I.R. CHANGES AFTER TEST X7R, 0402 - 25V

THICKNESS CODE		B (25V)	N (25V)	C (25V)
Capacitance		100pF~100nF	22nF~330nF	82nF~220nF
Electrical tests	D.F. [max.]	0.035	C≤100nF:0.035, C > 100nF:0.1	C≤100nF:0.035, C > 100nF:0.1
	I.R. [min.]	C≤25nF:10000MΩ, C>25nF:50Ω.F	C≤25nF:10000MΩ, C>25nF:50Ω.F	50Ω.F
	Measurement Frequency	1.0±0.1KHz	1.0±0.1KHz	1.0±0.1KHz
	Measurement Voltage [Vrms]	1.0±0.2	1.0±0.2	1.0±0.2
Resistance to soldering heat	Cap. [ΔC/C≤±%]	15	15	15
Substrate Bending test	Cap. [ΔC/C≤±%]	10	10	10
Vibration	Cap.[ΔC/C≤±%]	15	15	15
Rapid change of temperature	Cap. [ΔC/C≤±%]	15	15	15
Damp heat (steady state)	Cap. [ΔC/C≤±%]	12.5	12.5	12.5
	D.F. [max.]	0.07	C≤100nF:0.07, C > 100nF:0.2	C≤100nF:0.07, C > 100nF:0.2
	I.R. [min.]	500MΩ or 12.5Ω.F	500MΩ or 12.5Ω.F	500MΩ or 12.5Ω.F
High Temperature High Humidity (Steady)	Cap.[ΔC/C≤±%]	12.5	12.5	12.5
	D.F. [max.]	0.07	C≤100nF:0.07, C > 100nF:0.2	C≤100nF:0.07, C > 100nF:0.2
	I.R. [min.]	500MΩ or 12.5Ω.F	500MΩ or 12.5Ω.F	500MΩ or 12.5Ω.F
Endurance	Cap.[ΔC/C≤±%]	15	15	15
	D.F. [max.]	0.07	C≤100nF:0.07, C > 100nF:0.2	C≤100nF:0.07, C > 100nF:0.2
	I.R. [min.]	1000MΩ or 25Ω.F	1000MΩ or 25Ω.F	1000MΩ or 25Ω.F

CAP. \ D.F \ I.R. CHANGES AFTER TEST X7R, 0402 - 16V

THICKNESS CODE		B (16V)	N (16V)	
Capacitance		1nF~220nF	22nF~470nF	
Electrical tests	D.F. [max.]	C≤100nF:0.035, C > 100nF:0.1	C≤100nF:0.035, C > 100nF:0.1	
	I.R. [min.]	C≤25nF:10000MΩ, C>25nF:50Ω.F	C≤25nF:10000MΩ, C>25nF:50Ω.F	
	Measurement Frequency	1.0±0.1KHz	1.0±0.1KHz	
	Measurement Voltage [Vrms]	1.0±0.2	1.0±0.2	
Resistance to soldering heat	Cap. [ΔC/C±%]	15	15	
Substrate Bending test	Cap. [ΔC/C±%]	10	10	
Vibration	Cap.[ΔC/C±%]	15	15	
Rapid change of temperature	Cap. [ΔC/C±%]	15	15	
Damp heat (steady state)	Cap. [ΔC/C±%]	12.5	12.5	
	D.F. [max.]	C≤100nF:0.07, C > 100nF:0.2	C≤100nF:0.07, C > 100nF:0.2	
	I.R. [min.]	500MΩ or 12.5Ω·F	500MΩ or 12.5Ω·F	
High Temperature High Humidity (Steady)	Cap.[ΔC/C±%]	12.5	12.5	
	D.F. [max.]	C≤100nF:0.07, C > 100nF:0.2	C≤100nF:0.07, C > 100nF:0.2	
	I.R. [min.]	500MΩ or 12.5Ω·F	500MΩ or 12.5Ω·F	
Endurance	Cap.[ΔC/C±%]	15	15	
	D.F. [max.]	C≤100nF:0.07, C > 100nF:0.2	C≤100nF:0.07, C > 100nF:0.2	
	I.R. [min.]	1000MΩ or 10Ω·F	1000MΩ or 10Ω·F	

CAP. \ D.F \ I.R. CHANGES AFTER TEST X7R, 0402 - 10V & 6.3V

THICKNESS CODE		B (10V)	N (10V)	B (6.3V)
Capacitance		1nF~220nF	22nF~470nF	1nF~220nF
Electrical tests	D.F. [max.]	C≤100nF:0.035, C > 100nF:0.1	C≤100nF:0.035, C > 100nF:0.1	C≤100nF:0.035, C > 100nF:0.1
	I.R. [min.]	C≤25nF:10000MΩ, C>25nF:50Ω.F	C≤25nF:10000MΩ, C>25nF:50Ω.F	C≤25nF:10000MΩ, C>25nF:50Ω.F
	Measurement Frequency	1.0±0.1KHz	1.0±0.1KHz	1.0±0.1KHz
	Measurement Voltage [Vrms]	1.0±0.2	1.0±0.2	1.0±0.2
Resistance to soldering heat	Cap. [ΔC/C±%]	15	15	15
Substrate Bending test	Cap. [ΔC/C±%]	10	10	10
Vibration	Cap.[ΔC/C±%]	15	15	15
Rapid change of temperature	Cap. [ΔC/C±%]	15	15	15
Damp heat (steady state)	Cap. [ΔC/C±%]	12.5	12.5	12.5
	D.F. [max.]	C≤100nF:0.07, C > 100nF:0.2	C≤100nF:0.07, C > 100nF:0.2	C≤100nF:0.07, C > 100nF:0.2
	I.R. [min.]	500MΩ or 12.5Ω.F	500MΩ or 12.5Ω.F	500MΩ or 12.5Ω.F
High Temperature High Humidity (Steady)	Cap.[ΔC/C±%]	12.5	12.5	12.5
	D.F. [max.]	C≤100nF:0.07, C > 100nF:0.2	C≤100nF:0.07, C > 100nF:0.2	C≤100nF:0.07, C > 100nF:0.2
	I.R. [min.]	500MΩ or 12.5Ω.F	500MΩ or 12.5Ω.F	500MΩ or 12.5Ω.F
Endurance	Cap.[ΔC/C±%]	15	15	15
	D.F. [max.]	C≤100nF:0.07, C > 100nF:0.2	C≤100nF:0.07, C > 100nF:0.2	C≤100nF:0.07, C > 100nF:0.2
	I.R. [min.]	1000MΩ or 10Ω.F	1000MΩ or 10Ω.F	1000MΩ or 10Ω.F

CAP. \ D.F \ I.R. CHANGES AFTER TEST X7R, 0402 – 6.3V

THICKNESS CODE		N (6.3V)	N (6.3V)	
Capacitance		22nF~470nF	1μF	
Electrical tests	D.F. [max.]	C≤100nF:0.035, C > 100nF:0.1	0.1	
	I.R. [min.]	C≤25nF:10000MΩ, C>25nF:50Ω.F	50Ω.F	
	Measurement Frequency	1.0±0.1KHz	1.0±0.1KHz	
	Measurement Voltage [Vrms]	1.0±0.2	1.0±0.2	
Resistance to soldering heat	Cap. [ΔC/C≤±%]	15	15	
Substrate Bending test	Cap. [ΔC/C≤±%]	10	10	
Vibration	Cap.[ΔC/C≤±%]	15	15	
Rapid change of temperature	Cap. [ΔC/C≤±%]	15	15	
Damp heat (steady state)	Cap. [ΔC/C≤±%]	12.5	12.5	
	D.F. [max.]	C≤100nF:0.07, C > 100nF:0.2	:0.2	
	I.R. [min.]	500MΩ or 12.5Ω·F	500MΩ or 12.5Ω·F	
High Temperature High Humidity (Steady)	Cap.[ΔC/C≤±%]	12.5	12.5	
	D.F. [max.]	C≤100nF:0.07, C > 100nF:0.2	:0.2	
	I.R. [min.]	500MΩ or 12.5Ω·F	500MΩ or 12.5Ω·F	
Endurance	Cap.[ΔC/C≤±%]	15	15	
	D.F. [max.]	C≤100nF:0.07, C > 100nF:0.2	0.2	
	I.R. [min.]	1000MΩ or 10Ω·F	1000MΩ or 10Ω·F	

CAP. \ D.F \ I.R. CHANGES AFTER TEST X5R, 0402 - 50V

THICKNESS CODE		B (50V)	N (50V)	C (50V)
Capacitance		100pF~100nF	27nF~47nF	56nF~470nF
Electrical tests	D.F. [max.]	C≤47nF:0.035, C > 47nF:0.1	0.035	0.1
	I.R. [min.]	C≤25nF:10000MΩ, C>25nF:50Ω.F	50Ω.F	50Ω.F
	Measurement Frequency	1.0±0.1KHz	1.0±0.1KHz	1.0±0.1KHz
	Measurement Voltage [Vrms]	1.0±0.2	1.0±0.2	1.0±0.2
Resistance to soldering heat	Cap. [ΔC/C≤±%]	15	15	15
Substrate Bending test	Cap. [ΔC/C≤±%]	10	10	10
Vibration	Cap.[ΔC/C≤±%]	15	15	15
Rapid change of temperature	Cap. [ΔC/C≤±%]	15	15	15
Damp heat (steady state)	Cap. [ΔC/C≤±%]	15	15	15
	D.F. [max.]	C≤47nF:0.07, C > 47nF:0.2	0.07	0.2
	I.R. [min.]	500MΩ or 25Ω.F	500MΩ or 25Ω.F	500MΩ or 25Ω.F
High Temperature High Humidity (Steady)	Cap.[ΔC/C≤±%]	15	15	15
	D.F. [max.]	C≤47nF:0.07, C > 47nF:0.2	0.07	0.2
	I.R. [min.]	500MΩ or 25Ω.F	500MΩ or 25Ω.F	500MΩ 25Ω.F
Endurance	Cap.[ΔC/C≤±%]	15	15	15
	D.F. [max.]	C≤47nF:0.07, C > 47nF:0.2	0.07	0.2
	I.R. [min.]	1000MΩ or 50Ω.F	1000MΩ or 50Ω.F	1000MΩ or 50Ω.F

CAP. \ D.F \ I.R. CHANGES AFTER TEST X5R, 0402 - 35V & 25V

THICKNESS CODE		B (35V)	C (35V)	B (25V)
Capacitance		100pF~100nF	56nF~100nF	100pF~100nF
Electrical tests	D.F. [max.]	C≤47nF:0.035, C > 47nF:0.1	0.1	C≤47nF:0.035, C > 47nF:0.1
	I.R. [min.]	C≤25nF:10000MΩ, C>25nF:50Ω.F	50Ω.F	C≤25nF:10000MΩ, C>25nF:50Ω.F
	Measurement Frequency	1.0±0.1KHz	1.0±0.1KHz	1.0±0.1KHz
	Measurement Voltage [Vrms]	1.0±0.2	1.0±0.2	1.0±0.2
Resistance to soldering heat	Cap. [ΔC/C≤±%]	15	15	15
Substrate Bending test	Cap. [ΔC/C≤±%]	10	10	10
Vibration	Cap.[ΔC/C≤±%]	15	15	15
Rapid change of temperature	Cap. [ΔC/C≤±%]	15	15	15
Damp heat (steady state)	Cap. [ΔC/C≤±%]	15	15	15
	D.F. [max.]	C≤47nF:0.07, C > 47nF:0.2	0.2	C≤47nF:0.07, C > 47nF:0.2
	I.R. [min.]	500MΩ or 25Ω.F	500MΩ or 25Ω.F	500MΩ or 25Ω.F
High Temperature High Humidity (Steady)	Cap.[ΔC/C≤±%]	15	15	15
	D.F. [max.]	C≤47nF:0.07, C > 47nF:0.2	0.2	C≤47nF:0.07, C > 47nF:0.2
	I.R. [min.]	500MΩ or 25Ω.F	500MΩ 25Ω.F	500MΩ or 25Ω.F
Endurance	Cap.[ΔC/C≤±%]	15	15	15
	D.F. [max.]	C≤47nF:0.07, C > 47nF:0.2	0.2	C≤47nF:0.07, C > 47nF:0.2
	I.R. [min.]	1000MΩ or 50Ω.F	1000MΩ or 50Ω.F	1000MΩ or 50Ω.F

CAP. \ D.F \ I.R. CHANGES AFTER TEST X5R, 0402 - 25V 7 16V

THICKNESS CODE		N (25V)	C (25V)	B (16V)
Capacitance		82nF~470nF	270nF~2.2μF	100pF~1μF
Electrical tests	D.F. [max.]	0.1	0.1	C≤47nF:0.035, C > 47nF:0.1
	I.R. [min.]	50Ω.F	50Ω.F	C≤25nF:10000MΩ, C>25nF:50Ω.F
	Measurement Frequency	1.0±0.1KHz	1.0±0.1KHz	1.0±0.1KHz
	Measurement Voltage [Vrms]	1.0±0.2	1.0±0.2	1.0±0.2
Resistance to soldering heat	Cap. [ΔC/C≤±%]	15	15	15
Substrate Bending test	Cap. [ΔC/C≤±%]	10	10	10
Vibration	Cap.[ΔC/C≤±%]	15	15	15
Rapid change of temperature	Cap. [ΔC/C≤±%]	15	15	15
Damp heat (steady state)	Cap. [ΔC/C≤±%]	15	15	15
	D.F. [max.]	0.2	0.2	C≤47nF:0.07, C > 47nF:0.2
	I.R. [min.]	500MΩ or 25Ω.F	500MΩ or 25Ω.F	500MΩ or 25Ω.F
High Temperature High Humidity (Steady)	Cap.[ΔC/C≤±%]	15	15	15
	D.F. [max.]	0.2	0.2	C≤47nF:0.07, C > 47nF:0.2
	I.R. [min.]	500MΩ or 25Ω.F	500MΩ 25Ω.F	500MΩ or 25Ω.F
Endurance	Cap.[ΔC/C≤±%]	15	15	15
	D.F. [max.]	0.2	0.2	C≤47nF:0.07, C > 47nF:0.2
	I.R. [min.]	1000MΩ or 50Ω.F	1000MΩ or 50Ω.F	1000MΩ or 10Ω.F

CAP. \ D.F \ I.R. CHANGES AFTER TEST X5R, 0402 - 16V & 10V

THICKNESS CODE		N (16V)	N (16V)	B (10V)
Capacitance		120nF~470nF	2.2μF	100pF~1μF
Electrical tests	D.F. [max.]	0.1	0.1	C≤47nF:0.035, C > 47nF:0.1
	I.R. [min.]	50Ω.F	50Ω.F	C≤25nF:10000MΩ, C>25nF:50Ω.F
	Measurement Frequency	1.0±0.1KHz	1.0±0.1KHz	1.0±0.1KHz
	Measurement Voltage [Vrms]	1.0±0.2	1.0±0.2	1.0±0.2
Resistance to soldering heat	Cap. [ΔC/C≤±%]	15	15	15
Substrate Bending test	Cap. [ΔC/C≤±%]	10	10	10
Vibration	Cap.[ΔC/C≤±%]	15	15	15
Rapid change of temperature	Cap. [ΔC/C≤±%]	15	15	15
Damp heat (steady state)	Cap. [ΔC/C≤±%]	15	15	15
	D.F. [max.]	0.2	0.2	C≤47nF:0.07, C > 47nF:0.2
	I.R. [min.]	500MΩ or 25Ω.F	5Ω.F	500MΩ or 25Ω.F
High Temperature High Humidity (Steady)	Cap.[ΔC/C≤±%]	15	15	15
	D.F. [max.]	0.2	0.2	C≤47nF:0.07, C > 47nF:0.2
	I.R. [min.]	500MΩ or 25Ω.F	5Ω.F	500MΩ or 25Ω.F
Endurance	Cap.[ΔC/C≤±%]	15	15	15
	D.F. [max.]	0.2	0.2	C≤47nF:0.07, C > 47nF:0.2
	I.R. [min.]	1000MΩ or 10Ω.F	1000MΩ or 10Ω.F	1000MΩ or 10Ω.F

CAP. \ D.F \ I.R. CHANGES AFTER TEST X5R, 0402 - 10V

THICKNESS CODE		B (10V)	N (10V)	N (10V)
Capacitance		2.2μF	120nF~470nF	2.2μF
Electrical tests	D.F. [max.]	0.1	0.1	0.125
	I.R. [min.]	50Ω.F	50Ω.F	50Ω.F
	Measurement Frequency	1.0±0.1KHz	1.0±0.1KHz	1.0±0.1KHz
	Measurement Voltage [Vrms]	1.0±0.2	1.0±0.2	1.0±0.2
Resistance to soldering heat	Cap. [ΔC/C≤±%]	15	15	15
Substrate Bending test	Cap. [ΔC/C≤±%]	10	10	10
Vibration	Cap.[ΔC/C≤±%]	15	15	15
Rapid change of temperature	Cap. [ΔC/C≤±%]	15	15	15
Damp heat (steady state)	Cap. [ΔC/C≤±%]	15	15	25
	D.F. [max.]	0.2	0.2	0.2
	I.R. [min.]	5Ω.F	500MΩ or 25Ω.F	5Ω.F
High Temperature High Humidity (Steady)	Cap.[ΔC/C≤±%]	15	15	25
	D.F. [max.]	0.2	0.2	0.2
	I.R. [min.]	5Ω.F	500MΩ or 25Ω.F	5Ω.F
Endurance	Cap.[ΔC/C≤±%]	15	15	25
	D.F. [max.]	0.2	0.2	0.2
	I.R. [min.]	1000MΩ or 10Ω.F	1000MΩ or 10Ω.F	10Ω.F

CAP. \ D.F \ I.R. CHANGES AFTER TEST X5R, 0402 - 10V & 6.3V

THICKNESS CODE		C (10V)	B (6.3V)	B (6.3V)
Capacitance		4.7μF	100pF~820nF	1μF
Electrical tests	D.F. [max.]	0.1	C≤47nF:0.035, C > 47nF:0.1	0.1
	I.R. [min.]	50Ω.F	C≤25nF:10000MΩ, C>25nF:50Ω.F	50Ω.F
	Measurement Frequency	1.0±0.1KHz	1.0±0.1KHz	1.0±0.1KHz
	Measurement Voltage [Vrms]	1.0±0.2	1.0±0.2	1.0±0.2
Resistance to soldering heat	Cap. [ΔC/C≤±%]	15	15	15
Substrate Bending test	Cap. [ΔC/C≤±%]	10	10	10
Vibration	Cap.[ΔC/C≤±%]	15	15	15
Rapid change of temperature	Cap. [ΔC/C≤±%]	15	15	15
Damp heat (steady state)	Cap. [ΔC/C≤±%]	15	15	15
	D.F. [max.]	0.2	C≤47nF:0.07, C > 47nF:0.2	0.2
	I.R. [min.]	5Ω.F	500MΩ or 25Ω.F	500MΩ or 12.5Ω.F
High Temperature High Humidity (Steady)	Cap.[ΔC/C≤±%]	15	15	15
	D.F. [max.]	0.2	C≤47nF:0.07, C > 47nF:0.2	0.2
	I.R. [min.]	5Ω.F	500MΩ or 25Ω.F	500MΩ or 25Ω.F
Endurance	Cap.[ΔC/C≤±%]	15	15	15
	D.F. [max.]	0.2	C≤47nF:0.07, C > 47nF:0.2	0.2
	I.R. [min.]	1000MΩ or 10Ω.F	1000MΩ or 10Ω.F	1000MΩ or 10Ω.F

CAP. \ D.F \ I.R. CHANGES AFTER TEST X5R, 0402 – 6.3V

THICKNESS CODE		B (6.3V)	B (6.3V)	B (6.3V)
Capacitance		2.2μF	270nF~4.7μF	4.7μF
Electrical tests	D.F. [max.]	0.1	0.1	0.15
	I.R. [min.]	50Ω.F	50Ω.F	50Ω.F
	Measurement Frequency	1.0±0.1KHz	1.0±0.1KHz	1.0±0.1KHz
	Measurement Voltage [Vrms]	1.0±0.2	1.0±0.2	1.0±0.2
Resistance to soldering heat	Cap. [ΔC/C≤±%]	15	15	15
Substrate Bending test	Cap. [ΔC/C≤±%]	10	10	10
Vibration	Cap.[ΔC/C≤±%]	15	15	15
Rapid change of temperature	Cap. [ΔC/C≤±%]	15	15	15
Damp heat (steady state)	Cap. [ΔC/C≤±%]	25	15	15
	D.F. [max.]	0.2	0.2	0.2
	I.R. [min.]	5Ω.F	500MΩ or 25Ω.F	5Ω.F
High Temperature High Humidity (Steady)	Cap.[ΔC/C≤±%]	25	15	15
	D.F. [max.]	0.2	0.2	0.2
	I.R. [min.]	5Ω.F	500MΩ or 25Ω.F	5Ω.F
Endurance	Cap.[ΔC/C≤±%]	25	15	25
	D.F. [max.]	0.2	0.2	0.3
	I.R. [min.]	1000MΩ or 10Ω.F	1000MΩ or 10Ω.F	1000MΩ or 10Ω.F

CAP. \ D.F \ I.R. CHANGES AFTER TEST X5R, 0402 – 6.3V & 4V

THICKNESS CODE		B (6.3V)	U (6.3V)	C (4V)
Capacitance		10μF	10μF	10μF
Electrical tests	D.F. [max.]	0.15	0.15	0.15
	I.R. [min.]	50Ω.F	50Ω.F	50Ω.F
	Measurement Frequency	1.0±0.1KHz	1.0±0.1KHz	1.0±0.1KHz
	Measurement Voltage [Vrms]	1.0±0.2	1.0±0.2	1.0±0.2
Resistance to soldering heat	Cap. [ΔC/C≤±%]	15	15	15
Substrate Bending test	Cap. [ΔC/C≤±%]	10	10	10
Vibration	Cap.[ΔC/C≤±%]	15	15	15
Rapid change of temperature	Cap. [ΔC/C≤±%]	15	15	15
Damp heat (steady state)	Cap. [ΔC/C≤±%]	15	15	15
	D.F. [max.]	0.25	0.25	0.2
	I.R. [min.]	500MΩ or 3.5Ω.F	500MΩ or 3.5Ω.F	500MΩ or 25Ω.F
High Temperature High Humidity (Steady)	Cap.[ΔC/C≤±%]	15	15	15
	D.F. [max.]	0.25	0.25	0.2
	I.R. [min.]	500MΩ or 3.5Ω.F	500MΩ or 3.5Ω.F	500MΩ or 25Ω.F
Endurance	Cap.[ΔC/C≤±%]	15	15	25
	D.F. [max.]	0.25	0.25	0.2
	I.R. [min.]	1000MΩ or 7Ω.F	1000MΩ or 7Ω.F	1000MΩ or 10Ω.F

CAP. \ D.F \ I.R. CHANGES AFTER TEST X5R, 0402 – 4V

THICKNESS CODE (VOLTAGE)		C (4V)		
Capacitance		22μF		
Electrical tests	D.F. [max.]	0.15		
	I.R. [min.]	50Ω.F		
	Measurement Frequency	120±24KHz		
	Measurement Voltage [Vrms]	0.5.0±0.1		
Resistance to soldering heat	Cap. [ΔC/C≤±%]	15		
Substrate Bending test	Cap. [ΔC/C≤±%]	10		
Vibration	Cap.[ΔC/C≤±%]	15		
Rapid change of temperature	Cap. [ΔC/C≤±%]	15		
Damp heat (steady state)	Cap. [ΔC/C≤±%]	15		
	D.F. [max.]	0.2		
	I.R. [min.]	500MΩ or 25Ω.F		
High Temperature High Humidity (Steady)	Cap.[ΔC/C≤±%]	15		
	D.F. [max.]	0.2		
	I.R. [min.]	500MΩ or 25Ω.F		
Endurance	Cap.[ΔC/C≤±%]	15		
	D.F. [max.]	0.2		
	I.R. [min.]	1000MΩ or 10Ω.F		

CAP. \ D.F \ I.R. CHANGES AFTER TEST X7S, 0402 – 10V & 6.3V

THICKNESS CODE (VOLTAGE)		C (10V)	C (6.3V)	
Capacitance		1μF	1μF	
Electrical tests	D.F. [max.]	0.1	0.125	
	I.R. [min.]	50Ω.F	50Ω.F	
	Measurement Frequency	1.0±0.1KHz	1.0±0.1KHz	
	Measurement Voltage [Vrms]	1.0±0.2	1.0±0.2	
Resistance to soldering heat	Cap. [ΔC/C≤±%]	15	15	
Substrate Bending test	Cap. [ΔC/C≤±%]	12.5	12.5	
Vibration	Cap.[ΔC/C≤±%]	15	15	
Rapid change of temperature	Cap. [ΔC/C≤±%]	15	15	
Damp heat (steady state)	Cap. [ΔC/C≤±%]	15	15	
	D.F. [max.]	0.2	0.25	
	I.R. [min.]	500MΩ or 10Ω.F	500MΩ or 12.5Ω.F	
High Temperature High Humidity (Steady)	Cap.[ΔC/C≤±%]	15	15	
	D.F. [max.]	0.2	0.25	
	I.R. [min.]	500MΩ or 10Ω.F	500MΩ or 12.5Ω.F	
Endurance	Cap.[ΔC/C≤±%]	15	15	
	D.F. [max.]	0.2	0.25	
	I.R. [min.]	1000MΩ or 10Ω.F	1000MΩ or 10Ω.F	

CAP. \ D.F \ I.R. CHANGES AFTER TEST X7T, 0402 – 10V & 6.3V

THICKNESS CODE (VOLTAGE)		B (10V)	C (10V)	B (6.3V)
Capacitance		1 μ F	2.2 μ F	1 μ F
Electrical tests	D.F. [max.]	0.1	0.1	0.1
	I.R. [min.]	50 Ω ·F	50 Ω ·F	50 Ω ·F
	Measurement Frequency	1.0 \pm 0.1KHz	1.0 \pm 0.1KHz	1.0 \pm 0.1KHz
	Measurement Voltage [Vrms]	1.0 \pm 0.2	1.0 \pm 0.2	1.0 \pm 0.2
Resistance to soldering heat	Cap. [Δ C/C \leq \pm %]	15	15	15
Substrate Bending test	Cap. [Δ C/C \leq \pm %]	12.5	12.5	12.5
Vibration	Cap. [Δ C/C \leq \pm %]	15	15	15
Rapid change of temperature	Cap. [Δ C/C \leq \pm %]	15	15	15
Damp heat (steady state)	Cap. [Δ C/C \leq \pm %]	20	25	15
	D.F. [max.]	0.2	0.2	0.2
	I.R. [min.]	25 Ω ·F	500M Ω or 5 Ω ·F	500M Ω or 25 Ω ·F
High Temperature High Humidity (Steady)	Cap. [Δ C/C \leq \pm %]	20	25	15
	D.F. [max.]	0.2	0.2	0.2
	I.R. [min.]	25 Ω ·F	500M Ω or 5 Ω ·F	500M Ω or 25 Ω ·F
Endurance	Cap. [Δ C/C \leq \pm %]	15	25	15
	D.F. [max.]	0.2	0.2	0.2
	I.R. [min.]	50 Ω ·F	1000M Ω or 10 Ω ·F	1000M Ω or 10 Ω ·F

CAP. \ D.F \ I.R. CHANGES AFTER TEST X7T, 0402 – 6.3V & 4V

THICKNESS CODE (VOLTAGE)		N (6.3V)	C (6.3V)	N (4V)
Capacitance		1μF	2.2μF	1μF
Electrical tests	D.F. [max.]	0.1	0.1	0.1
	I.R. [min.]	50Ω.F	50Ω.F	50Ω.F
	Measurement Frequency	1.0±0.1KHz	1.0±0.1KHz	1.0±0.1KHz
	Measurement Voltage [Vrms]	1.0±0.2	1.0±0.2	1.0±0.2
Resistance to soldering heat	Cap. [ΔC/C≤±%]	15	15	15
Substrate Bending test	Cap. [ΔC/C≤±%]	12.5	12.5	12.5
Vibration	Cap.[ΔC/C≤±%]	15	15	15
Rapid change of temperature	Cap. [ΔC/C≤±%]	15	15	15
Damp heat (steady state)	Cap. [ΔC/C≤±%]	15	15	15
	D.F. [max.]	0.2	0.2	0.2
	I.R. [min.]	500MΩ or 25Ω.F	500MΩ or 25Ω.F	500MΩ or 25Ω.F
High Temperature High Humidity (Steady)	Cap.[ΔC/C≤±%]	15	15	15
	D.F. [max.]	0.2	0.2	0.2
	I.R. [min.]	1000MΩ or 25Ω.F	1000MΩ or 25Ω.F	1000MΩ or 25Ω.F
Endurance	Cap.[ΔC/C≤±%]	15	25	15
	D.F. [max.]	0.2	0.2	0.2
	I.R. [min.]	1000MΩ or 10Ω.F	1000MΩ or 10Ω.F	1000MΩ or 10Ω.F

CAP. \ D.F \ I.R. CHANGES AFTER TEST X6S, 0402 – 50V & 25V

THICKNESS CODE (VOLTAGE)		B (50V)	C (50V)	B (25V)
Capacitance		15nF~47nF	100nF	68nF~100nF
Electrical tests	D.F. [max.]	0.1	0.1	0.1
	I.R. [min.]	50Ω.F	50Ω.F	50Ω.F
	Measurement Frequency	1.0±0.1KHz	1.0±0.1KHz	1.0±0.1KHz
	Measurement Voltage [Vrms]	1.0±0.2	1.0±0.2	1.0±0.2
Resistance to soldering heat	Cap. [$\Delta C/C \leq \pm\%$]	15	15	15
Substrate Bending test	Cap. [$\Delta C/C \leq \pm\%$]	12.5	12.5	12.5
Vibration	Cap. [$\Delta C/C \leq \pm\%$]	15	15	15
Rapid change of temperature	Cap. [$\Delta C/C \leq \pm\%$]	15	15	15
Damp heat (steady state)	Cap. [$\Delta C/C \leq \pm\%$]	15	15	15
	D.F. [max.]	0.2	0.2	0.2
	I.R. [min.]	500MΩ or 25Ω.F	500MΩ or 25Ω.F	500MΩ or 25Ω.F
High Temperature High Humidity (Steady)	Cap. [$\Delta C/C \leq \pm\%$]	15	15	15
	D.F. [max.]	0.2	0.2	0.2
	I.R. [min.]	500MΩ or 25Ω.F	500MΩ or 25Ω.F	500MΩ or 25Ω.F
Endurance	Cap. [$\Delta C/C \leq \pm\%$]	15	25	15
	D.F. [max.]	0.2	0.2	0.2
	I.R. [min.]	1000MΩ or 50Ω.F	1000MΩ or 50Ω.F	1000MΩ or 50Ω.F

CAP. \ D.F \ I.R. CHANGES AFTER TEST X6S, 0402 – 25V & 16V

THICKNESS CODE (VOLTAGE)		C (25V)	N (25V)	B (16V)
Capacitance		220nF~1.0μF	220nF~470nF	100nF~1μF
Electrical tests	D.F. [max.]	0.1	0.1	0.125
	I.R. [min.]	50Ω.F	50Ω.F	50Ω.F
	Measurement Frequency	1.0±0.1KHz	1.0±0.1KHz	1.0±0.1KHz
	Measurement Voltage [Vrms]	1.0±0.2	1.0±0.2	1.0±0.2
Resistance to soldering heat	Cap. [ΔC/C≤±%]	15	15	15
Substrate Bending test	Cap. [ΔC/C≤±%]	12.5	12.5	12.5
Vibration	Cap.[ΔC/C≤±%]	15	15	15
Rapid change of temperature	Cap. [ΔC/C≤±%]	15	15	15
Damp heat (steady state)	Cap. [ΔC/C≤±%]	25	25	15
	D.F. [max.]	0.2	0.2	0.2
	I.R. [min.]	50Ω.F	50Ω.F	500MΩ or 25Ω.F
High Temperature High Humidity (Steady)	Cap.[ΔC/C≤±%]	25	25	15
	D.F. [max.]	0.2	0.2	0.2
	I.R. [min.]	50Ω.F	50Ω.F	500MΩ or 25Ω.F
Endurance	Cap.[ΔC/C≤±%]	25	25	15
	D.F. [max.]	0.2	0.2	0.2
	I.R. [min.]	10Ω.F	10Ω.F	1000MΩ or 10Ω.F

CAP. \ D.F \ I.R. CHANGES AFTER TEST X6S, 0402 – 16V

THICKNESS CODE (VOLTAGE)		N (16V)	C (16V)	C (16V)
Capacitance		220nF~470nF	220nF	1μF
Electrical tests	D.F. [max.]	0.125	0.125	0.125
	I.R. [min.]	50Ω.F	50Ω.F	50Ω.F
	Measurement Frequency	1.0±0.1KHz	1.0±0.1KHz	1.0±0.1KHz
	Measurement Voltage [Vrms]	1.0±0.2	1.0±0.2	1.0±0.2
Resistance to soldering heat	Cap. [ΔC/C≤±%]	15	15	15
Substrate Bending test	Cap. [ΔC/C≤±%]	12.5	12.5	12.5
Vibration	Cap.[ΔC/C≤±%]	15	15	15
Rapid change of temperature	Cap. [ΔC/C≤±%]	15	15	15
Damp heat (steady state)	Cap. [ΔC/C≤±%]	15	15	20
	D.F. [max.]	0.2	0.2	0.2
	I.R. [min.]	500MΩ or 25Ω.F	500MΩ or 25Ω.F	12.5Ω.F
High Temperature High Humidity (Steady)	Cap.[ΔC/C≤±%]	15	15	20
	D.F. [max.]	0.2	0.2	0.2
	I.R. [min.]	500MΩ or 25Ω.F	500MΩ or 25Ω.F	12.5Ω.F
Endurance	Cap.[ΔC/C≤±%]	15	15	15
	D.F. [max.]	0.2	0.2	0.2
	I.R. [min.]	1000MΩ or 10Ω.F	1000MΩ or 10Ω.F	25Ω.F

CAP. \ D.F \ I.R. CHANGES AFTER TEST X6S, 0402 – 16V & 10V

THICKNESS CODE (VOLTAGE)		C (16V)	B (10V)	N (10V)
Capacitance		2.2μF	1μF	220nF~470nF
Electrical tests	D.F. [max.]	0.125	0.125	0.125
	I.R. [min.]	50Ω.F	50Ω.F	50Ω.F
	Measurement Frequency	1.0±0.1KHz	1.0±0.1KHz	1.0±0.1KHz
	Measurement Voltage [Vrms]	1.0±0.2	1.0±0.2	1.0±0.2
Resistance to soldering heat	Cap. [ΔC/C≤±%]	15	15	15
Substrate Bending test	Cap. [ΔC/C≤±%]	12.5	12.5	12.5
Vibration	Cap.[ΔC/C≤±%]	15	15	15
Rapid change of temperature	Cap. [ΔC/C≤±%]	15	15	15
Damp heat (steady state)	Cap. [ΔC/C≤±%]	15	15	15
	D.F. [max.]	0.2	0.2	0.2
	I.R. [min.]	500MΩ or 25Ω.F	500MΩ or 25Ω.F	500MΩ or 25Ω.F
High Temperature High Humidity (Steady)	Cap.[ΔC/C≤±%]	15	15	15
	D.F. [max.]	0.2	0.2	0.2
	I.R. [min.]	500MΩ or 25Ω.F	500MΩ or 25Ω.F	500MΩ or 25Ω.F
Endurance	Cap.[ΔC/C≤±%]	15	15	15
	D.F. [max.]	0.2	0.2	0.2
	I.R. [min.]	1000MΩ or 10Ω.F	1000MΩ or 10Ω.F	1000MΩ or 10Ω.F

CAP. \ D.F \ I.R. CHANGES AFTER TEST X6S, 0402 – 10V & 6.3V

THICKNESS CODE (VOLTAGE)		N (10V)	C (10V)	B (6.3V)
Capacitance		4.7μF	2.2μF	1μF
Electrical tests	D.F. [max.]	0.15	0.125	0.125
	I.R. [min.]	50Ω·F	50Ω·F	50Ω·F
	Measurement Frequency	1.0±0.1KHz	1.0±0.1KHz	1.0±0.1KHz
	Measurement Voltage [Vrms]	1.0±0.2	1.0±0.2	1.0±0.2
Resistance to soldering heat	Cap. [ΔC/C≤±%]	15	15	15
Substrate Bending test	Cap. [ΔC/C≤±%]	12.5	12.5	12.5
Vibration	Cap.[ΔC/C≤±%]	15	15	15
Rapid change of temperature	Cap. [ΔC/C≤±%]	15	15	15
Damp heat (steady state)	Cap. [ΔC/C≤±%]	15	15	15
	D.F. [max.]	0.2	0.2	0.2
	I.R. [min.]	500MΩ or 25Ω·F	500MΩ or 25Ω·F	500MΩ or 25Ω·F
High Temperature High Humidity (Steady)	Cap.[ΔC/C≤±%]	15	15	15
	D.F. [max.]	0.2	0.2	0.2
	I.R. [min.]	500MΩ or 25Ω·F	500MΩ or 25Ω·F	500MΩ or 25Ω·F
Endurance	Cap.[ΔC/C≤±%]	15	15	15
	D.F. [max.]	0.2	0.2	0.2
	I.R. [min.]	1000MΩ or 10Ω·F	1000MΩ or 10Ω·F	1000MΩ or 10Ω·F

CAP. \ D.F \ I.R. CHANGES AFTER TEST X6S, 0402 –6.3V

THICKNESS CODE (VOLTAGE)		N (6.3V)	N (6.3V)	C (6.3V)
Capacitance		220nF~470nF	2.2μF	1μF~4.7μF
Electrical tests	D.F. [max.]	0.15	0.125	0.125
	I.R. [min.]	50Ω.F	50Ω.F	50Ω.F
	Measurement Frequency	1.0±0.1KHz	1.0±0.1KHz	1.0±0.1KHz
	Measurement Voltage [Vrms]	1.0±0.2	1.0±0.2	1.0±0.2
Resistance to soldering heat	Cap. [ΔC/C≤±%]	15	15	15
Substrate Bending test	Cap. [ΔC/C≤±%]	12.5	12.5	12.5
Vibration	Cap.[ΔC/C≤±%]	15	15	15
Rapid change of temperature	Cap. [ΔC/C≤±%]	15	15	15
Damp heat (steady state)	Cap. [ΔC/C≤±%]	15	15	15
	D.F. [max.]	0.2	0.2	0.2
	I.R. [min.]	500MΩ or 25Ω.F	500MΩ or 25Ω.F	500MΩ or 25Ω.F
High Temperature High Humidity (Steady)	Cap.[ΔC/C≤±%]	15	15	15
	D.F. [max.]	0.2	0.2	0.2
	I.R. [min.]	500MΩ or 25Ω.F	500MΩ or 25Ω.F	500MΩ or 25Ω.F
Endurance	Cap.[ΔC/C≤±%]	15	15	15
	D.F. [max.]	0.2	0.2	0.2
	I.R. [min.]	1000MΩ or 10Ω.F	1000MΩ or 10Ω.F	1000MΩ or 10Ω.F

CAP. \ D.F \ I.R. CHANGES AFTER TEST X6S, 0402 –4V

THICKNESS CODE (VOLTAGE)		B (4V)	C (4V)	
Capacitance		1μF~2.2μF	10μF	
Electrical tests	D.F. [max.]	0.15	0.1	
	I.R. [min.]	50Ω.F	50Ω.F	
	Measurement Frequency	1.0±0.1KHz	1.0±0.1KHz	
	Measurement Voltage [Vrms]	1.0±0.2	1.0±0.2	
Resistance to soldering heat	Cap. [ΔC/C≤±%]	15	15	
Substrate Bending test	Cap. [ΔC/C≤±%]	12.5	12.5	
Vibration	Cap.[ΔC/C≤±%]	15	15	
Rapid change of temperature	Cap. [ΔC/C≤±%]	15	15	
Damp heat (steady state)	Cap. [ΔC/C≤±%]	15	25	
	D.F. [max.]	0.2	0.2	
	I.R. [min.]	500MΩ or 25Ω.F	5Ω.F	
High Temperature High Humidity (Steady)	Cap.[ΔC/C≤±%]	15	25	
	D.F. [max.]	0.2	0.2	
	I.R. [min.]	500MΩ or 25Ω.F	5Ω.F	
Endurance	Cap.[ΔC/C≤±%]	15	25	
	D.F. [max.]	0.2	0.2	
	I.R. [min.]	1000MΩ or 10Ω.F	10Ω.F	

CAP. \ D.F \ I.R. CHANGES AFTER TEST X7R, 0603 - 50V & 25V

THICKNESS CODE		D (50V)	K (50V)	D (25V)
Capacitance		220pF~820nF	47nF~470nF	100nF~820nF
Electrical tests	D.F. [max.]	C≤100nF:0.035, C > 100nF:0.1	C≤100nF:0.035, C > 100nF:0.1	C≤100nF:0.035, C > 100nF:0.1
	I.R. [min.]	C≤25nF:10000MΩ, C>25nF:100Ω.F	100Ω.F	100Ω.F
	Measurement Frequency	1.0±0.1KHz	1.0±0.1KHz	1.0±0.1KHz
	Measurement Voltage [Vrms]	1.0±0.2	1.0±0.2	1.0±0.2
Resistance to soldering heat	Cap. [ΔC/C±%]	15	15	15
Substrate Bending test	Cap. [ΔC/C±%]	10	10	10
Vibration	Cap.[ΔC/C±%]	15	15	15
Rapid change of temperature	Cap. [ΔC/C±%]	15	15	15
Damp heat (steady state)	Cap. [ΔC/C±%]	12.5	12.5	12.5
	D.F. [max.]	C≤100nF:0.07, C > 100nF:0.2	C≤100nF:0.07, C > 100nF:0.2	C≤100nF:0.07, C > 100nF:0.2
	I.R. [min.]	500MΩ or 25Ω.F	500MΩ or 25Ω.F	500MΩ or 25Ω.F
High Temperature High Humidity (Steady)	Cap.[ΔC/C±%]	12.5	12.5	12.5
	D.F. [max.]	C≤100nF:0.07, C > 100nF:0.2	C≤100nF:0.07, C > 100nF:0.2	C≤100nF:0.07, C > 100nF:0.2
	I.R. [min.]	500MΩ or 25Ω.F	500MΩ or 25Ω.F	500MΩ or 25Ω.F
Endurance	Cap.[ΔC/C±%]	15	15	15
	D.F. [max.]	C≤100nF:0.07, C > 100nF:0.2	C≤100nF:0.07, C > 100nF:0.2	C≤100nF:0.07, C > 100nF:0.2
	I.R. [min.]	1000MΩ or 50Ω.F	1000MΩ or 50Ω.F	1000MΩ or 50Ω.F

CAP. \ D.F \ I.R. CHANGES AFTER TEST X7R, 0603 - 25V & 16V

THICKNESS CODE		D (25V)	K (25V)	D (16V)
Capacitance		1 μ F	100nF~1 μ F	1nF~1 μ F
Electrical tests	D.F. [max.]	0.1	0.1	C \leq 100nF:0.035, C > 100nF:0.1
	I.R. [min.]	100 Ω ·F	100 Ω ·F	100 Ω ·F
	Measurement Frequency	1.0 \pm 0.1KHz	1.0 \pm 0.1KHz	1.0 \pm 0.1KHz
	Measurement Voltage [Vrms]	1.0 \pm 0.2	1.0 \pm 0.2	1.0 \pm 0.2
Resistance to soldering heat	Cap. [Δ C/C \leq \pm %]	15	15	15
Substrate Bending test	Cap. [Δ C/C \leq \pm %]	10	10	10
Vibration	Cap.[Δ C/C \leq \pm %]	15	15	15
Rapid change of temperature	Cap. [Δ C/C \leq \pm %]	15	15	15
Damp heat (steady state)	Cap. [Δ C/C \leq \pm %]	12.5	12.5	12.5
	D.F. [max.]	0.2	0.2	C \leq 100nF:0.07, C > 100nF:0.2
	I.R. [min.]	500M Ω or 25 Ω ·F	500M Ω or 25 Ω ·F	500M Ω or 25 Ω ·F
High Temperature High Humidity (Steady)	Cap.[Δ C/C \leq \pm %]	12.5	12.5	12.5
	D.F. [max.]	0.2	0.2	C \leq 100nF:0.07, C > 100nF:0.2
	I.R. [min.]	500M Ω or 25 Ω ·F	500M Ω or 25 Ω ·F	500M Ω or 25 Ω ·F
Endurance	Cap.[Δ C/C \leq \pm %]	15	15	15
	D.F. [max.]	0.2	0.2	C \leq 100nF:0.07, C > 100nF:0.2
	I.R. [min.]	1000M Ω or 50 Ω ·F	1000M Ω or 50 Ω ·F	1000M Ω or 10 Ω ·F

CAP. \ D.F \ I.R. CHANGES AFTER TEST X7R, 0603 - 16V & 10V

THICKNESS CODE		K (16V)	D (10V)	D (10V)
Capacitance		100nF~1μF	100nF~820nF	2.2μF
Electrical tests	D.F. [max.]	C≤100nF:0.035, C > 100nF:0.1	C≤100nF:0.035, C > 100nF:0.1	0.1
	I.R. [min.]	100Ω.F	100Ω.F	100Ω.F
	Measurement Frequency	1.0±0.1KHz	1.0±0.1KHz	1.0±0.1KHz
	Measurement Voltage [Vrms]	1.0±0.2	1.0±0.2	1.0±0.2
Resistance to soldering heat	Cap. [ΔC/C±%]	15	15	15
Substrate Bending test	Cap. [ΔC/C±%]	10	10	10
Vibration	Cap.[ΔC/C±%]	15	15	15
Rapid change of temperature	Cap. [ΔC/C±%]	15	15	15
Damp heat (steady state)	Cap. [ΔC/C±%]	12.5	12.5	12.5
	D.F. [max.]	C≤100nF:0.07, C > 100nF:0.2	C≤100nF:0.07, C > 100nF:0.2	0.2
	I.R. [min.]	500MΩ or 25Ω.F	500MΩ or 25Ω.F	5Ω.F
High Temperature High Humidity (Steady)	Cap.[ΔC/C±%]	12.5	12.5	12.5
	D.F. [max.]	C≤100nF:0.07, C > 100nF:0.2	C≤100nF:0.07, C > 100nF:0.2	0.2
	I.R. [min.]	500MΩ or 25Ω.F	500MΩ or 25Ω.F	5Ω.F
Endurance	Cap.[ΔC/C±%]	15	15	15
	D.F. [max.]	C≤100nF:0.07, C > 100nF:0.2	C≤100nF:0.07, C > 100nF:0.2	0.2
	I.R. [min.]	1000MΩ or 50Ω.F	1000MΩ or 50Ω.F	1000MΩ or 10Ω.F

CAP. \ D.F \ I.R. CHANGES AFTER TEST X7R, 0603 - 10V & 6.3V

THICKNESS CODE		K (10V)	K (10V)	D (6.3V)
Capacitance		100nF~1μF	2.2μF	100nF~820nF
Electrical tests	D.F. [max.]	C≤100nF:0.035, C > 100nF:0.1	0.1	C≤100nF:0.035, C > 100nF:0.1
	I.R. [min.]	100Ω.F	100Ω.F	100Ω.F
	Measurement Frequency	1.0±0.1KHz	1.0±0.1KHz	1.0±0.1KHz
	Measurement Voltage [Vrms]	1.0±0.2	1.0±0.2	1.0±0.2
Resistance to soldering heat	Cap. [ΔC/C±%]	15	15	15
Substrate Bending test	Cap. [ΔC/C±%]	10	10	10
Vibration	Cap.[ΔC/C±%]	15	15	15
Rapid change of temperature	Cap. [ΔC/C±%]	15	15	15
Damp heat (steady state)	Cap. [ΔC/C±%]	12.5	12.5	12.5
	D.F. [max.]	C≤100nF:0.07, C > 100nF:0.2	0.2	C≤100nF:0.07, C > 100nF:0.2
	I.R. [min.]	500MΩ or 25Ω.F	500MΩ or 12.5Ω.F	500MΩ or 25Ω.F
High Temperature High Humidity (Steady)	Cap.[ΔC/C±%]	12.5	12.5	12.5
	D.F. [max.]	C≤100nF:0.07, C > 100nF:0.2	0.2	C≤100nF:0.07, C > 100nF:0.2
	I.R. [min.]	500MΩ or 25Ω.F	500MΩ or 12.5Ω.F	500MΩ or 25Ω.F
Endurance	Cap.[ΔC/C±%]	15	12.5	15
	D.F. [max.]	C≤100nF:0.07, C > 100nF:0.2	0.2	C≤100nF:0.07, C > 100nF:0.2
	I.R. [min.]	1000MΩ or 50Ω.F	1000MΩ or 25Ω.F	1000MΩ or 50Ω.F

CAP. \ D.F \ I.R. CHANGES AFTER TEST X7R, 0603 - 6.3V

THICKNESS CODE		K (6.3V)	K (6.3V)	K (6.3V)
Capacitance		100nF~1μF	2.2μF	4.7μF
Electrical tests	D.F. [max.]	C≤100nF:0.035, C > 100nF:0.1	0.1	0.1
	I.R. [min.]	100Ω·F	100Ω·F	100Ω·F
	Measurement Frequency	1.0±0.1KHz	1.0±0.1KHz	1.0±0.1KHz
	Measurement Voltage [Vrms]	1.0±0.2	1.0±0.2	1.0±0.2
Resistance to soldering heat	Cap. [ΔC/C≤±%]	15	15	15
Substrate Bending test	Cap. [ΔC/C≤±%]	10	10	10
Vibration	Cap.[ΔC/C≤±%]	15	15	15
Rapid change of temperature	Cap. [ΔC/C≤±%]	15	15	15
Damp heat (steady state)	Cap. [ΔC/C≤±%]	12.5	12.5	12.5
	D.F. [max.]	C≤100nF:0.07, C > 100nF:0.2	0.2	0.2
	I.R. [min.]	500MΩ or 25Ω·F	5Ω·F	5Ω·F
High Temperature High Humidity (Steady)	Cap.[ΔC/C≤±%]	15	25	15
	D.F. [max.]	C≤100nF:0.07, C > 100nF:0.2	0.2	0.2
	I.R. [min.]	500MΩ or 25Ω·F	5Ω·F	5Ω·F
Endurance	Cap.[ΔC/C≤±%]	15	25	15
	D.F. [max.]	C≤100nF:0.07, C > 100nF:0.2	0.2	0.2
	I.R. [min.]	1000MΩ or 50Ω·F	10Ω·F	1000MΩ or 10Ω·F

CAP. \ D.F \ I.R. CHANGES AFTER TEST X5R, 0603 - 50V

THICKNESS CODE		D (50V)	D (50V)	K (50V)
Capacitance		220pF~820nF	1μF	2.2μF
Electrical tests	D.F. [max.]	0.1	0.1	0.1
	I.R. [min.]	C≤25nF:10000MΩ, C>25nF:50Ω.F	50Ω.F	50Ω.F
	Measurement Frequency	1.0±0.1KHz	1.0±0.1KHz	1.0±0.1KHz
	Measurement Voltage [Vrms]	1.0±0.2	1.0±0.2	1.0±0.2
Resistance to soldering heat	Cap. [ΔC/C≤±%]	15	15	15
Substrate Bending test	Cap. [ΔC/C≤±%]	10	10	10
Vibration	Cap.[ΔC/C≤±%]	15	15	15
Rapid change of temperature	Cap. [ΔC/C≤±%]	15	15	15
Damp heat (steady state)	Cap. [ΔC/C≤±%]	12.5	12.5	12.5
	D.F. [max.]	0.2	0.2	0.2
	I.R. [min.]	500MΩ or 25Ω.F	500MΩ or 12.5Ω.F	500MΩ or 25Ω.F
High Temperature High Humidity (Steady)	Cap.[ΔC/C≤±%]	15	15	15
	D.F. [max.]	0.2	0.2	0.2
	I.R. [min.]	500MΩ or 25Ω.F	500MΩ or 12.5Ω.F	500MΩ or 25Ω.F
Endurance	Cap.[ΔC/C≤±%]	15	15	15
	D.F. [max.]	0.2	0.2	0.2
	I.R. [min.]	1000MΩ or 50Ω.F	1000MΩ or 25Ω.F	1000MΩ or 50Ω.F

CAP. \ D.F \ I.R. CHANGES AFTER TEST X5R, 0603 - 35V & 25V

THICKNESS CODE		D (35V)	S (25V)	D (25V)
Capacitance		680nF~820nF	680nF~820nF	100nF~820nF
Electrical tests	D.F. [max.]	0.1	0.1	0.1
	I.R. [min.]	100Ω.F	100Ω.F	100Ω.F
	Measurement Frequency	1.0±0.1KHz	1.0±0.1KHz	1.0±0.1KHz
	Measurement Voltage [Vrms]	1.0±0.2	1.0±0.2	1.0±0.2
Resistance to soldering heat	Cap. [ΔC/C≤±%]	15	15	15
Substrate Bending test	Cap. [ΔC/C≤±%]	10	10	10
Vibration	Cap.[ΔC/C≤±%]	15	15	15
Rapid change of temperature	Cap. [ΔC/C≤±%]	15	15	15
Damp heat (steady state)	Cap. [ΔC/C≤±%]	12.5	12.5	12.5
	D.F. [max.]	0.2	0.2	0.2
	I.R. [min.]	500MΩ or 25Ω.F	500MΩ or 25Ω.F	500MΩ or 25Ω.F
High Temperature High Humidity (Steady)	Cap.[ΔC/C≤±%]	15	15	15
	D.F. [max.]	0.2	0.2	0.2
	I.R. [min.]	500MΩ or 25Ω.F	500MΩ or 25Ω.F	500MΩ or 25Ω.F
Endurance	Cap.[ΔC/C≤±%]	15	15	15
	D.F. [max.]	0.2	0.2	0.2
	I.R. [min.]	1000MΩ or 50Ω.F	1000MΩ or 50Ω.F	1000MΩ or 50Ω.F

CAP. \ D.F \ I.R. CHANGES AFTER TEST X5R, 0603 - 25V

THICKNESS CODE		D (25V)	D (25V)	K (25V)
Capacitance		1 μ F	2.2 μ F	1 μ F~10 μ F
Electrical tests	D.F. [max.]	0.1	0.1	0.15
	I.R. [min.]	100 Ω .F	50 Ω .F	50 Ω .F
	Measurement Frequency	1.0 \pm 0.1KHz	1.0 \pm 0.1KHz	1.0 \pm 0.1KHz
	Measurement Voltage [Vrms]	1.0 \pm 0.2	1.0 \pm 0.2	1.0 \pm 0.2
Resistance to soldering heat	Cap. [Δ C/C \leq \pm %]	15	15	15
Substrate Bending test	Cap. [Δ C/C \leq \pm %]	10	10	10
Vibration	Cap.[Δ C/C \leq \pm %]	15	15	15
Rapid change of temperature	Cap. [Δ C/C \leq \pm %]	15	15	15
Damp heat (steady state)	Cap. [Δ C/C \leq \pm %]	15	12.5	15
	D.F. [max.]	0.2	0.2	0.2
	I.R. [min.]	500M Ω or 12.5 Ω ·F	12.5 Ω ·F	500M Ω or 25 Ω ·F
High Temperature High Humidity (Steady)	Cap.[Δ C/C \leq \pm %]	15	12.5	15
	D.F. [max.]	0.2	0.2	0.2
	I.R. [min.]	500M Ω or 12.5 Ω ·F	12.5 Ω ·F	500M Ω or 25 Ω ·F
Endurance	Cap.[Δ C/C \leq \pm %]	15	12.5	15
	D.F. [max.]	0.2	0.2	0.2
	I.R. [min.]	1000M Ω or 25 Ω ·F	25 Ω ·F	1000M Ω or 50 Ω ·F

CAP. \ D.F \ I.R. CHANGES AFTER TEST X5R, 0603 - 16V

THICKNESS CODE		S (16V)	D (16V)	K (16V)
Capacitance		680nF~820nF	220nF~2.2μF	4.7μF~10μF
Electrical tests	D.F. [max.]	0.125	0.1	0.125
	I.R. [min.]	100Ω.F	100Ω.F	100Ω.F
	Measurement Frequency	1.0±0.1KHz	1.0±0.1KHz	1.0±0.1KHz
	Measurement Voltage [Vrms]	1.0±0.2	1.0±0.2	1.0±0.2
Resistance to soldering heat	Cap. [ΔC/C≤±%]	15	15	15
Substrate Bending test	Cap. [ΔC/C≤±%]	10	10	10
Vibration	Cap.[ΔC/C≤±%]	15	15	15
Rapid change of temperature	Cap. [ΔC/C≤±%]	15	15	15
Damp heat (steady state)	Cap. [ΔC/C≤±%]	15	15	15
	D.F. [max.]	0.2	0.2	0.2
	I.R. [min.]	500MΩ or 25Ω.F	500MΩ or 25Ω.F	500MΩ or 25Ω.F
High Temperature High Humidity (Steady)	Cap.[ΔC/C≤±%]	15	15	15
	D.F. [max.]	0.2	0.2	0.2
	I.R. [min.]	500MΩ or 25Ω.F	500MΩ or 25Ω.F	500MΩ or 25Ω.F
Endurance	Cap.[ΔC/C≤±%]	15	15	15
	D.F. [max.]	0.2	0.2	0.2
	I.R. [min.]	1000MΩ or 10Ω.F	1000MΩ or 10Ω.F	1000MΩ or 10Ω.F

CAP. \ D.F \ I.R. CHANGES AFTER TEST X5R, 0603 - 10V

THICKNESS CODE		S (10V)	D (10V)	K (10V)
Capacitance		4.7μF	680nF~4.7μF	5.6μF~10μF
Electrical tests	D.F. [max.]	0.15	0.15	0.15
	I.R. [min.]	100Ω.F	100Ω.F	100Ω.F
	Measurement Frequency	1.0±0.1KHz	1.0±0.1KHz	1.0±0.1KHz
	Measurement Voltage [Vrms]	1.0±0.2	1.0±0.2	1.0±0.2
Resistance to soldering heat	Cap. [ΔC/C≤±%]	15	15	15
Substrate Bending test	Cap. [ΔC/C≤±%]	10	10	10
Vibration	Cap.[ΔC/C≤±%]	15	15	15
Rapid change of temperature	Cap. [ΔC/C≤±%]	15	15	15
Damp heat (steady state)	Cap. [ΔC/C≤±%]	30	15	15
	D.F. [max.]	0.2	0.2	0.2
	I.R. [min.]	2Ω·F	500MΩ or 25Ω·F	500MΩ or 25Ω·F
High Temperature High Humidity (Steady)	Cap.[ΔC/C≤±%]	30	15	15
	D.F. [max.]	0.2	0.2	0.2
	I.R. [min.]	2Ω·F	500MΩ or 25Ω·F	500MΩ or 25Ω·F
Endurance	Cap.[ΔC/C≤±%]	30	15	15
	D.F. [max.]	0.2	0.2	0.2
	I.R. [min.]	2Ω·F	1000MΩ or 10Ω·F	1000MΩ or 10Ω·F

CAP. \ D.F \ I.R. CHANGES AFTER TEST X5R, 0603 - 10V & 6.3V

THICKNESS CODE		K (10V)	D (6.3V)	K (6.3V)
Capacitance		22μF	1μF~10μF	8.2μF~10μF
Electrical tests	D.F. [max.]	0.15	0.15	0.15
	I.R. [min.]	100Ω.F	100Ω.F	100Ω.F
	Measurement Frequency	120±24Hz	1.0±0.1KHz	1.0±0.1KHz
	Measurement Voltage [Vrms]	0.5±0.1	1.0±0.2	1.0±0.2
Resistance to soldering heat	Cap. [ΔC/C≤±%]	15	15	15
Substrate Bending test	Cap. [ΔC/C≤±%]	10	10	10
Vibration	Cap.[ΔC/C≤±%]	15	15	15
Rapid change of temperature	Cap. [ΔC/C≤±%]	15	15	15
Damp heat (steady state)	Cap. [ΔC/C≤±%]	15	15	15
	D.F. [max.]	0.2	0.2	0.2
	I.R. [min.]	500MΩ or 25Ω.F	500MΩ or 25Ω.F	500MΩ or 25Ω.F
High Temperature High Humidity (Steady)	Cap.[ΔC/C≤±%]	15	15	15
	D.F. [max.]	0.2	0.2	0.2
	I.R. [min.]	500MΩ or 25Ω.F	500MΩ or 25Ω.F	500MΩ or 25Ω.F
Endurance	Cap.[ΔC/C≤±%]	15	15	15
	D.F. [max.]	0.2	0.2	0.2
	I.R. [min.]	1000MΩ or 10Ω.F	1000MΩ or 10Ω.F	1000MΩ or 10Ω.F

CAP. \ D.F \ I.R. CHANGES AFTER TEST X5R, 0603 – 6.3V & 4V

THICKNESS CODE		K (10V)	K (4V)	K (4V)
Capacitance		22μF	10μF	22μF
Electrical tests	D.F. [max.]	0.15	0.15	0.15
	I.R. [min.]	100Ω.F	100Ω.F	100Ω.F
	Measurement Frequency	120±24Hz	1.0±0.1KHz	120±24Hz
	Measurement Voltage [Vrms]	0.5±0.1	1.0±0.2	0.5±0.1
Resistance to soldering heat	Cap. [ΔC/C≤±%]	15	15	15
Substrate Bending test	Cap. [ΔC/C≤±%]	10	10	10
Vibration	Cap.[ΔC/C≤±%]	15	15	15
Rapid change of temperature	Cap. [ΔC/C≤±%]	15	15	15
Damp heat (steady state)	Cap. [ΔC/C≤±%]	15	15	15
	D.F. [max.]	0.2	0.2	0.2
	I.R. [min.]	500MΩ or 8.8Ω.F	500MΩ or 25Ω.F	500MΩ or 25Ω.F
High Temperature High Humidity (Steady)	Cap.[ΔC/C≤±%]	15	15	15
	D.F. [max.]	0.2	0.2	0.2
	I.R. [min.]	500MΩ or 8.8Ω.F	500MΩ or 25Ω.F	500MΩ or 25Ω.F
Endurance	Cap.[ΔC/C≤±%]	15	15	15
	D.F. [max.]	0.2	0.2	0.2
	I.R. [min.]	1000MΩ or 17.7Ω.F	1000MΩ or 10Ω.F	1000MΩ or 10Ω.F

CAP. \ D.F \ I.R. CHANGES AFTER TEST X5R, 0603 – 4V

THICKNESS CODE		K (4V)		
Capacitance		47µF		
Electrical tests	D.F. [max.]	0.15		
	I.R. [min.]	100Ω.F		
	Measurement Frequency	120±24Hz		
	Measurement Voltage [Vrms]	0.5±0.1		
Resistance to soldering heat	Cap. [ΔC/C≤±%]	15		
Substrate Bending test	Cap. [ΔC/C≤±%]	10		
Vibration	Cap.[ΔC/C≤±%]	15		
Rapid change of temperature	Cap. [ΔC/C≤±%]	15		
Damp heat (steady state)	Cap. [ΔC/C≤±%]	15		
	D.F. [max.]	0.2		
	I.R. [min.]	500MΩ or 25Ω.F		
High Temperature High Humidity (Steady)	Cap.[ΔC/C≤±%]	15		
	D.F. [max.]	0.2		
	I.R. [min.]	500MΩ or 25Ω.F		
Endurance	Cap.[ΔC/C≤±%]	15		
	D.F. [max.]	0.2		
	I.R. [min.]	1000MΩ or 10Ω.F		

CAP. \ D.F \ I.R. CHANGES AFTER TEST X7S, 0603 – 25V & 16V

THICKNESS CODE		K (25V)	K (16V)	K (16V)
Capacitance		1μF~2.2μF	1μF	2.2μF
Electrical tests	D.F. [max.]	0.1	0.1	0.1
	I.R. [min.]	50Ω.F	50Ω.F	50Ω.F
	Measurement Frequency	1.0±0.1KHz	1.0±0.1KHz	1.0±0.1KHz
	Measurement Voltage [Vrms]	1.0±0.2	1.0±0.2	1.0±0.2
Resistance to soldering heat	Cap. [ΔC/C≤±%]	15	15	15
Substrate Bending test	Cap. [ΔC/C≤±%]	12.5	12.5	12.5
Vibration	Cap.[ΔC/C≤±%]	15	15	15
Rapid change of temperature	Cap. [ΔC/C≤±%]	15	15	15
Damp heat (steady state)	Cap. [ΔC/C≤±%]	15	15	15
	D.F. [max.]	0.2	0.2	0.2
	I.R. [min.]	500MΩ or 12.5Ω·F	500MΩ or 12.5Ω·F	500MΩ or 12.5Ω·F
High Temperature High Humidity (Steady)	Cap.[ΔC/C≤±%]	15	15	15
	D.F. [max.]	0.2	0.2	0.2
	I.R. [min.]	500MΩ or 12.5Ω·F	500MΩ or 12.5Ω·F	500MΩ or 12.5Ω·F
Endurance	Cap.[ΔC/C≤±%]	15	15	15
	D.F. [max.]	0.2	0.2	0.2
	I.R. [min.]	1000MΩ or 25Ω·F	1000MΩ or 25Ω·F	1000MΩ or 25Ω·F

CAP. \ D.F \ I.R. CHANGES AFTER TEST X7S, 0603 – 16V, 10V & 6.3V

THICKNESS CODE		K (25V)	K (10V)	K (6.3V)
Capacitance		4.7μF	4.7μF	4.7μF
Electrical tests	D.F. [max.]	0.1	0.125	0.1
	I.R. [min.]	50Ω.F	50Ω.F	50Ω.F
	Measurement Frequency	1.0±0.1KHz	1.0±0.1KHz	1.0±0.1KHz
	Measurement Voltage [Vrms]	1.0±0.2	1.0±0.2	1.0±0.2
Resistance to soldering heat	Cap. [ΔC/C≤±%]	15	15	15
Substrate Bending test	Cap. [ΔC/C≤±%]	12.5	12.5	12.5
Vibration	Cap.[ΔC/C≤±%]	15	15	15
Rapid change of temperature	Cap. [ΔC/C≤±%]	15	15	15
Damp heat (steady state)	Cap. [ΔC/C≤±%]	12.5	12.5	12.5
	D.F. [max.]	0.2	0.2	0.2
	I.R. [min.]	500MΩ or 12.5Ω·F	500MΩ or 12.5Ω·F	500MΩ or 12.5Ω·F
High Temperature High Humidity (Steady)	Cap.[ΔC/C≤±%]	12.5	12.5	12.5
	D.F. [max.]	0.2	0.2	0.2
	I.R. [min.]	500MΩ or 12.5Ω·F	500MΩ or 12.5Ω·F	500MΩ or 12.5Ω·F
Endurance	Cap.[ΔC/C≤±%]	15	15	12.5
	D.F. [max.]	0.2	0.2	0.2
	I.R. [min.]	1000MΩ or 25Ω·F	1000MΩ or 25Ω·F	1000MΩ or 25Ω·F

CAP. \ D.F \ I.R. CHANGES AFTER TEST X7T, 0603 – 10V & 6.3V

THICKNESS CODE		K (10V)	K (6.3V)	
Capacitance		2.2μF~10μF	10μF	
Electrical tests	D.F. [max.]	0.1	0.1	
	I.R. [min.]	50Ω·F	50Ω·F	
	Measurement Frequency	1.0±0.1KHz	1.0±0.1KHz	
	Measurement Voltage [Vrms]	1.0±0.2	1.0±0.2	
Resistance to soldering heat	Cap. [ΔC/C≤±%]	15	15	
Substrate Bending test	Cap. [ΔC/C≤±%]	12.5	12.5	
Vibration	Cap.[ΔC/C≤±%]	15	15	
Rapid change of temperature	Cap. [ΔC/C≤±%]	15	15	
Damp heat (steady state)	Cap. [ΔC/C≤±%]	25	25	
	D.F. [max.]	0.2	0.2	
	I.R. [min.]	5Ω·F	5Ω·F	
High Temperature High Humidity (Steady)	Cap.[ΔC/C≤±%]	25	25	
	D.F. [max.]	0.2	0.2	
	I.R. [min.]	5Ω·F	5Ω·F	
Endurance	Cap.[ΔC/C≤±%]	25	25	
	D.F. [max.]	0.2	0.2	
	I.R. [min.]	10Ω·F	10Ω·F	

CAP. \ D.F \ I.R. CHANGES AFTER TEST X6S, 0603 – 25V & 16V

THICKNESS CODE		K (25V)	K (25V)	D (16V)
Capacitance		2.2μF	4.7μF	1μF
Electrical tests	D.F. [max.]	0.1	0.1	0.1
	I.R. [min.]	50Ω.F	50Ω.F	50Ω.F
	Measurement Frequency	1.0±0.1KHz	1.0±0.1KHz	1.0±0.1KHz
	Measurement Voltage [Vrms]	1.0±0.2	1.0±0.2	1.0±0.2
Resistance to soldering heat	Cap. [ΔC/C≤±%]	15	15	15
Substrate Bending test	Cap. [ΔC/C≤±%]	12.5	12.5	12.5
Vibration	Cap.[ΔC/C≤±%]	15	15	15
Rapid change of temperature	Cap. [ΔC/C≤±%]	15	15	15
Damp heat (steady state)	Cap. [ΔC/C≤±%]	15	15	30
	D.F. [max.]	0.2	0.2	0.125
	I.R. [min.]	500MΩ or 25Ω.F	12.5Ω.F	12.5Ω.F
High Temperature High Humidity (Steady)	Cap.[ΔC/C≤±%]	15	15	30
	D.F. [max.]	0.2	0.2	0.125
	I.R. [min.]	500MΩ or 25Ω.F	12.5Ω.F	12.5Ω.F
Endurance	Cap.[ΔC/C≤±%]	15	15	20
	D.F. [max.]	0.2	0.2	0.125
	I.R. [min.]	1000MΩ or 50Ω.F	25Ω.F	25Ω.F

CAP. \ D.F \ I.R. CHANGES AFTER TEST X6S, 0603 – 16V, 10V & 6.3V

THICKNESS CODE		K (16V)	K (10V)	D (6.3V)
Capacitance		2.2μF~10μF	10μF	4.7μF
Electrical tests	D.F. [max.]	0.1	0.125	0.1
	I.R. [min.]	50Ω.F	50Ω.F	100Ω.F
	Measurement Frequency	1.0±0.1KHz	1.0±0.1KHz	1.0±0.1KHz
	Measurement Voltage [Vrms]	1.0±0.2	1.0±0.2	1.0±0.2
Resistance to soldering heat	Cap. [ΔC/C≤±%]	15	15	15
Substrate Bending test	Cap. [ΔC/C≤±%]	12.5	12.5	12.5
Vibration	Cap.[ΔC/C≤±%]	15	15	15
Rapid change of temperature	Cap. [ΔC/C≤±%]	15	15	15
Damp heat (steady state)	Cap. [ΔC/C≤±%]	15	15	25
	D.F. [max.]	0.2	0.2	0.2
	I.R. [min.]	500MΩ or 25Ω.F	500MΩ or 12.5Ω.F	5Ω.F
High Temperature High Humidity (Steady)	Cap.[ΔC/C≤±%]	15	15	25
	D.F. [max.]	0.2	0.2	0.2
	I.R. [min.]	500MΩ or 25Ω.F	500MΩ or 12.5Ω.F	5Ω.F
Endurance	Cap.[ΔC/C≤±%]	15	15	25
	D.F. [max.]	0.2	0.2	0.2
	I.R. [min.]	1000MΩ or 50Ω.F	1000MΩ or 10Ω.F	10Ω.F

CAP. \ D.F \ I.R. CHANGES AFTER TEST X6S, 0603 – 6.3V

THICKNESS CODE		K (6.3V)	K (6.3V)	W (6.3V)
Capacitance		4.7μF	10μF	22μF
Electrical tests	D.F. [max.]	0.1	0.15	0.1
	I.R. [min.]	50Ω.F	50Ω.F	50Ω.F
	Measurement Frequency	1.0±0.1KHz	1.0±0.1KHz	120±24KHz
	Measurement Voltage [Vrms]	1.0±0.2	1.0±0.2	0.5±0.1
Resistance to soldering heat	Cap. [ΔC/C≤±%]	15	15	15
Substrate Bending test	Cap. [ΔC/C≤±%]	12.5	12.5	12.5
Vibration	Cap.[ΔC/C≤±%]	15	15	15
Rapid change of temperature	Cap. [ΔC/C≤±%]	15	15	15
Damp heat (steady state)	Cap. [ΔC/C≤±%]	15	15	25
	D.F. [max.]	0.2	0.2	0.2
	I.R. [min.]	500MΩ or 12.5Ω·F	500MΩ or 25Ω·F	5Ω·F
High Temperature High Humidity (Steady)	Cap.[ΔC/C≤±%]	15	15	25
	D.F. [max.]	0.2	0.2	0.2
	I.R. [min.]	500MΩ or 12.5Ω·F	500MΩ or 25Ω·F	5Ω·F
Endurance	Cap.[ΔC/C≤±%]	15	15	25
	D.F. [max.]	0.2	0.2	0.2
	I.R. [min.]	1000MΩ or 25Ω·F	1000MΩ or 10Ω·F	10Ω·F

CAP. \ D.F \ I.R. CHANGES AFTER TEST X6S, 0603 – 4V

THICKNESS CODE		K (4V)	K (4V)	W (4V)
Capacitance		10 μ F	22 μ F	22 μ F
Electrical tests	D.F. [max.]	0.1	0.1	0.1
	I.R. [min.]	50 Ω .F	50 Ω .F	50 Ω .F
	Measurement Frequency	1.0 \pm 0.1KHz	120 \pm 24KHz	120 \pm 24KHz
	Measurement Voltage [Vrms]	1.0 \pm 0.2	0.5 \pm 0.1	0.5 \pm 0.1
Resistance to soldering heat	Cap. [Δ C/C \leq \pm %]	15	15	15
Substrate Bending test	Cap. [Δ C/C \leq \pm %]	12.5	12.5	12.5
Vibration	Cap.[Δ C/C \leq \pm %]	15	15	15
Rapid change of temperature	Cap. [Δ C/C \leq \pm %]	15	15	15
Damp heat (steady state)	Cap. [Δ C/C \leq \pm %]	15	15	15
	D.F. [max.]	0.2	0.2	0.25
	I.R. [min.]	500M Ω or 25 Ω .F	500M Ω or 25 Ω .F	500M Ω or 8.8 Ω .F
High Temperature High Humidity (Steady)	Cap.[Δ C/C \leq \pm %]	15	15	15
	D.F. [max.]	0.2	0.2	0.25
	I.R. [min.]	500M Ω or 25 Ω .F	500M Ω or 25 Ω .F	500M Ω or 8.8 Ω .F
Endurance	Cap.[Δ C/C \leq \pm %]	15	15	15
	D.F. [max.]	0.2	0.2	0.25
	I.R. [min.]	1000M Ω or 10 Ω .F	1000M Ω or 10 Ω .F	1000M Ω or 10 Ω .F

CAP. \ D.F \ I.R. CHANGES AFTER TEST X6S, 0603 – 2.5V

THICKNESS CODE		K (2.5V)		
Capacitance		47μF		
Electrical tests	D.F. [max.]	0.1		
	I.R. [min.]	50Ω.F		
	Measurement Frequency	120±24KHz		
	Measurement Voltage [Vrms]	0.5±0.1		
Resistance to soldering heat	Cap. [ΔC/C≤±%]	15		
Substrate Bending test	Cap. [ΔC/C≤±%]	12.5		
Vibration	Cap.[ΔC/C≤±%]	15		
Rapid change of temperature	Cap. [ΔC/C≤±%]	15		
Damp heat (steady state)	Cap. [ΔC/C≤±%]	15		
	D.F. [max.]	0.25		
	I.R. [min.]	500MΩ or 10Ω·F		
High Temperature High Humidity (Steady)	Cap.[ΔC/C≤±%]	15		
	D.F. [max.]	0.25		
	I.R. [min.]	500MΩ or 1Ω·F		
Endurance	Cap.[ΔC/C≤±%]	15		
	D.F. [max.]	0.25		
	I.R. [min.]	1000MΩ or 1Ω·F		

PACKAGING STYLE AND QUANTITY PER REEL

SIZE CODE	METRIC CODE	THICKNESS CODE	SQUARE HOLE SPACING	DISC SIZE	CARRIER TAPE	QTY (KPCS)	PACKAGING CODE
0402	1005	B	2.0mm	7 #	Paper	10	T
0402	1005	N	2.0mm	7 #	Paper	10	T
0402	1005	C	2.0mm	7 #	Paper	10	T
0402	1005	U	2.0mm	7 #	Paper	8	C
0402	1005	U	2.0mm	7 #	Paper	10	T
0603	1608	S	4.0mm	7 #	Paper	4	T
0603	1608	D	4.0mm	7 #	Paper	4	T
0603	1608	D	4.0mm	7 #	Paper	3	W
0603	1608	K	4.0mm	7 #	Paper	4	T
0603	1608	K	4.0mm	7 #	Paper	3	W
0603	1608	K	4.0mm	7 #	Plastic	4	Q
0603	1608	K	4.0mm	7 #	Plastic	3	R
0603	1608	W	4.0mm	7 #	Plastic	3	R
0603	1608	W	4.0mm	7 #	Plastic	4	Q

PERFORMANCE OF CARRIER TAPING

- Strength of Carrier Tape and Top Cover Tape
- Carrier Tape: When a tensile force 1.02kgf is applied in the direction to unreel the tape, the tape shall withstand this force.
- Top cover Tape: When a tensile force 1.02kgf is applied to the tape, the tape shall withstand this force.
- Peeling Strength of Top Cover Tape: Unless otherwise specified, the peeling strength of top cover tape shall be within 10.2 to 71.4 gf when the top cover tape is pulled at a speed of 300mm/min with the angle of 0 to 15°

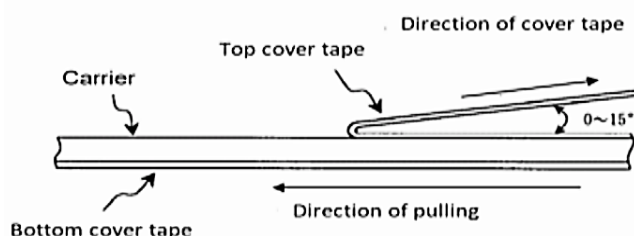

TAPE DIMENSION (Unit: mm), Paper Tape Type

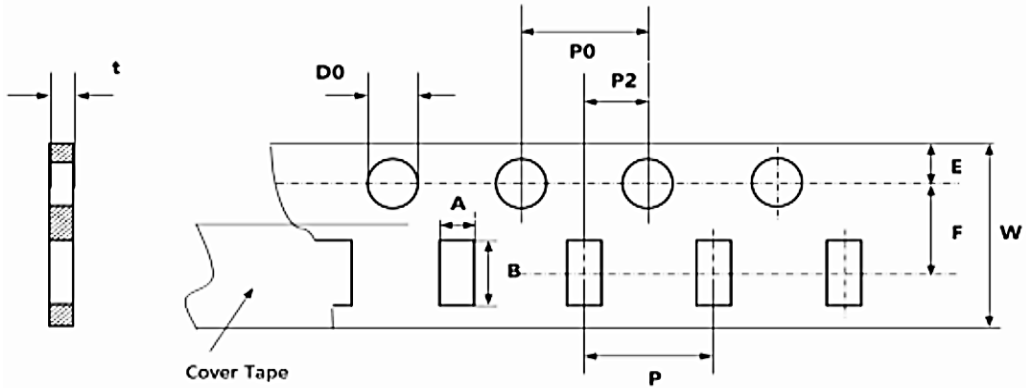

SIZE CODE		0402 (2MM PITCH)				0603		
Package Code		T, J	T, J	T, J	C, T	T, A, W	T, A, W	T
Thickness Code		B	C	N	U	D	K	S
Symbol	A	0.63±0.05	0.70±0.10	0.75±0.10	0.85±0.10	1.00±0.10	1.10±0.10	1.10±0.10
	B	1.13±0.05	1.20±0.10	1.30±0.10	1.40±0.10	1.80±0.10	1.90±0.10	1.90±0.10
	F	3.50±0.05	3.50±0.05	3.50±0.05	3.50±0.05	3.50±0.05	3.50±0.05	3.50±0.05
	P	2.00±0.05	2.00±0.05	2.00±0.05	2.00±0.05	4.00±0.10	4.00±0.10	4.00±0.10
	E	1.75±0.10	1.75±0.10	1.75±0.10	1.75±0.10	1.75±0.10	1.75±0.10	1.75±0.10
	D0	1.55±0.05	1.55±0.05	1.55±0.05	1.55±0.05	1.55±0.05	1.55±0.05	1.55±0.05
	P2	2.00±0.05	2.00±0.05	2.00±0.05	2.00±0.05	2.00±0.05	2.00±0.05	2.00±0.05
	K	/	/	/	/	/	/	/
	W	8.00±0.10	8.00±0.10	8.00±0.10	8.00±0.10	8.00±0.20	8.00±0.20	8.00±0.20
	P0	4.00±0.10	4.00±0.10	4.00±0.10	4.00±0.10	4.00±0.10	4.00±0.10	4.00±0.10
t	0.8max	0.8max	0.8max	0.95max	1.15max	1.15max	0.70max	

TAPE DIMENSION (Unit: mm), Plastic Tape Type

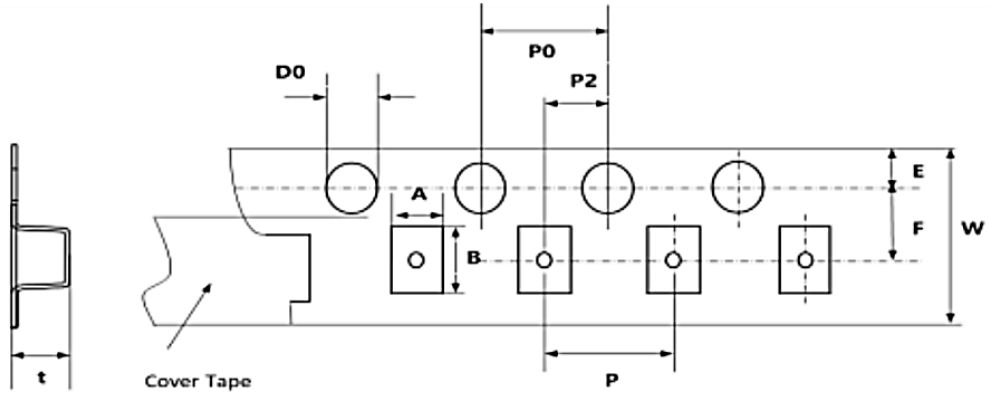

SIZE CODE		0603		
Package Code	O	O, Q, R	O, Q, R	O, Q, R
Thickness Code	D	K	W	
Symbol	A	1.00±0.10	1.10±0.10	1.10±0.10
	B	1.80±0.10	1.90±0.10	1.90±0.10
	F	3.50±0.05	3.50±0.05	3.50±0.05
	P	4.00±0.10	4.00±0.10	4.00±0.10
	E	1.75±0.10	1.75±0.10	1.75±0.10
	D0	1.55±0.05	1.55±0.05	1.55±0.05
	P2	2.00±0.05	2.00±0.05	2.00±0.05
	K	/	/	/
	W	8.00±0.20	8.00±0.20	8.00±0.20
	P0	4.00±0.10	4.00±0.10	4.00±0.10
	t	1.15max	1.15max	1.35max

REEL DIMENSION (Unit: mm)

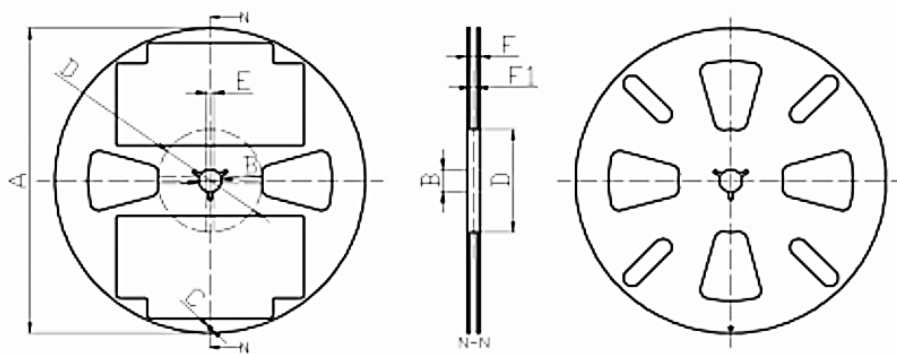

SIZE CODE	0402, 0603
Reel Size	7"
Width of carrier	8.00±0.10
A	Φ178±2.0
B	Φ13±1.0
C	Φ4.0±0.5
D	Φ60±2.0
E	4.0±1.0
F	11.5±1.0
F1	10.0±2

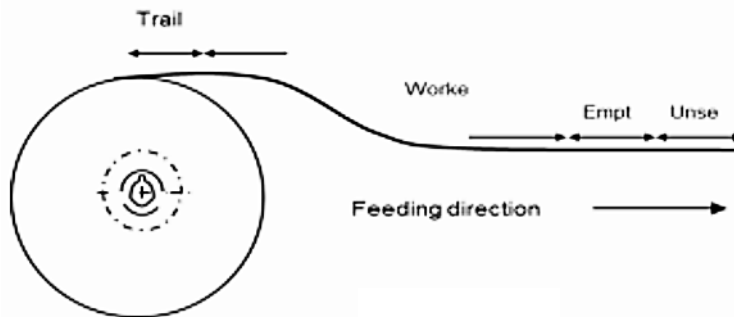

PACKAGING	THE MINIMUM LENGTH OF THE RESERVED SPACES		
	Trailer	Empty	Unseal
Carrier	60	200	160

IMPORTANT NOTES AND DISCLAIMER

1. **ROHS COMPLIANCE:** The levels of RoHS restricted materials in this product are below the maximum concentration values (also referred to as the threshold limits) permitted for such substances, or are used in an exempted application, in accordance with EU RoHS Directive (EU) 2015/863 EC (RoHS3). RoHS Test Report for this product can be obtained at Download Center.
2. **REACH COMPLIANCE:** REACH substances of high concern (SVHCs) information is available for this product. Since the European Chemical Agency (ECHA) has published notice of their intent to frequently revise the SVHC listing for the foreseeable future, REACH Test Report for this product can be obtained at Download Center.
3. All Product parametric performance is indicated in the Electrical Characteristics for the listed herein test conditions, unless otherwise noted. Product performance may not be indicated by the Electrical Characteristics if operated under different conditions.
4. NextGen Component, Inc (*NextGen*) reserves the right to make changes to this document and its products and specifications at any time without notice. Customers should obtain and confirm the latest product information and specifications before final design, purchase or use.
5. *NextGen* makes no warranty, representation or guarantee regarding the suitability of its products for any particular purpose, not does *NextGen* assume any liability for application assistance or customer product design.
6. *NextGen* does not warrant or accept any liability with products which are purchased or used for any unintended or unauthorized application. No license is granted by implication or otherwise under any intellectual property rights of NextGen.
7. *NextGen* products are not authorized for use as critical components in life support devices or systems without express written approval by *NextGen*.
8. *NextGen* requires that customers first obtain an RMA (Returned Merchandise Authorization) number prior to returning any products. Returns must be made within 30 days of the date of invoice, be in the original packaging, unused and like-new condition. At the time of quoting or purchasing, a product may say that it is Non-Cancelable/ Non-Returnable (NCNR). These products are not returnable and not refundable.